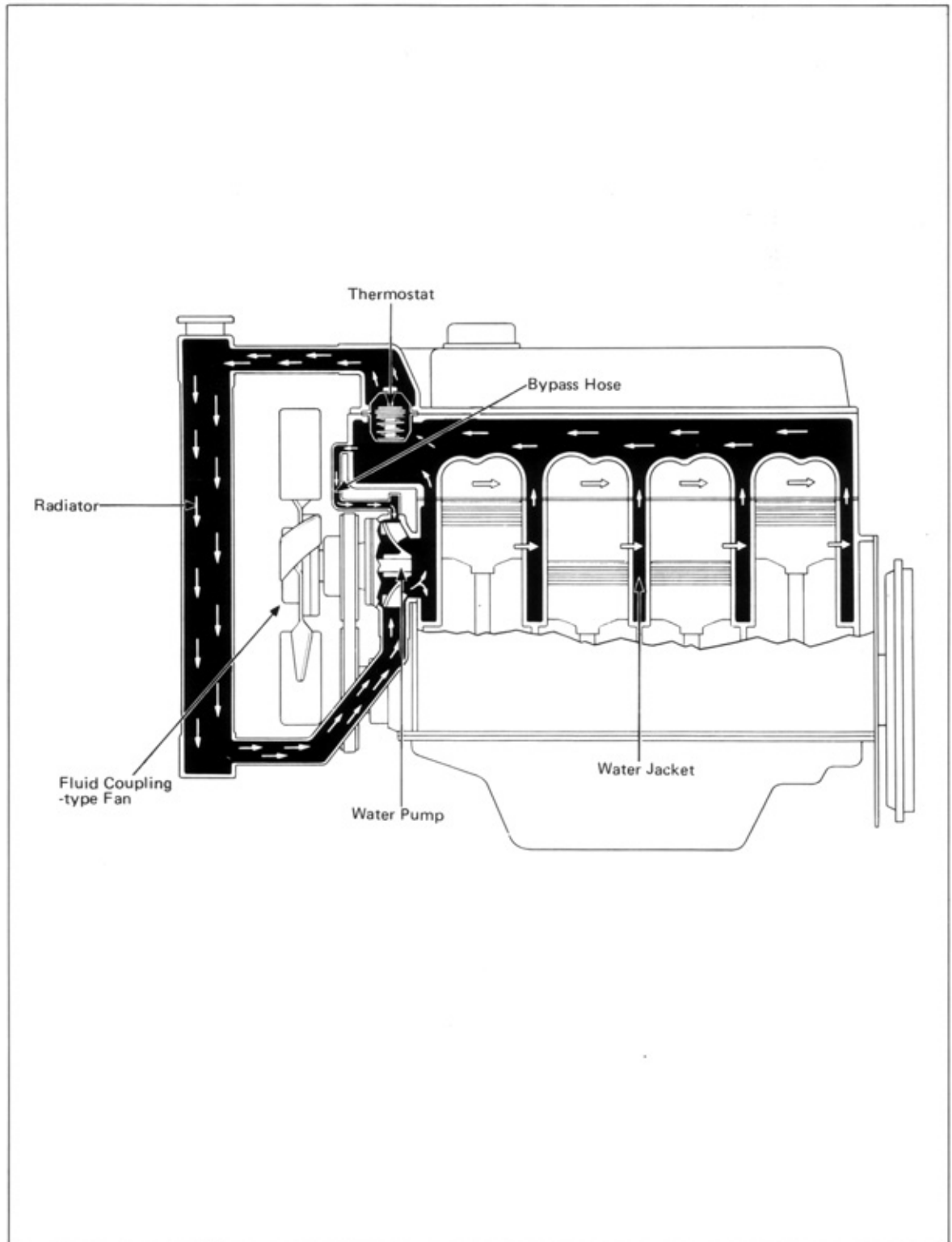


# COOLING SYSTEM

	Page
COOLING SYSTEM CIRCUIT.....	7-2
WATER PUMP SECTIONAL VIEW .....	7-3
WATER PUMP (WITHOUT TEMPERED COOLING FAN)	
DISASSEMBLY .....	7-4
ASSEMBLY .....	7-6
WATER PUMP (WITH TEMPERED COOLING FAN)	
DISASSEMBLY .....	7-9
INSPECTION .....	7-10
ASSEMBLY .....	7-11
RADIATOR	
INSPECTION & REPAIR.....	7-13
THERMOSTAT	
INSPECTION .....	7-13

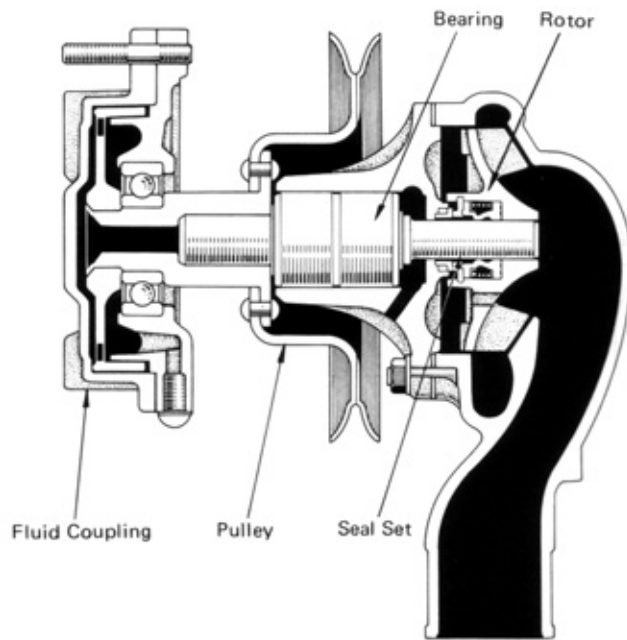
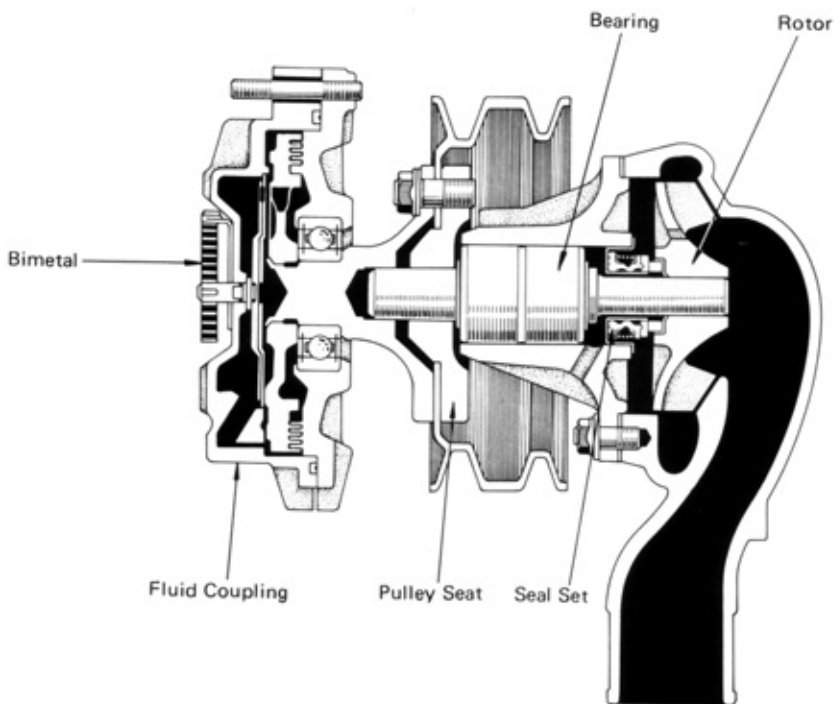
# COOLING SYSTEM CIRCUIT

Fig. 7-1



**WATER PUMP SECTIONAL VIEW**

Fig. 7-2

**WITHOUT TEMPERED COOLING FAN****WITH TEMPERED COOLING FAN**

## WATER PUMP(WITHOUT TEMPERED COOLING FAN) DISASSEMBLY

Disassemble in numerical order.

Fig. 7-3

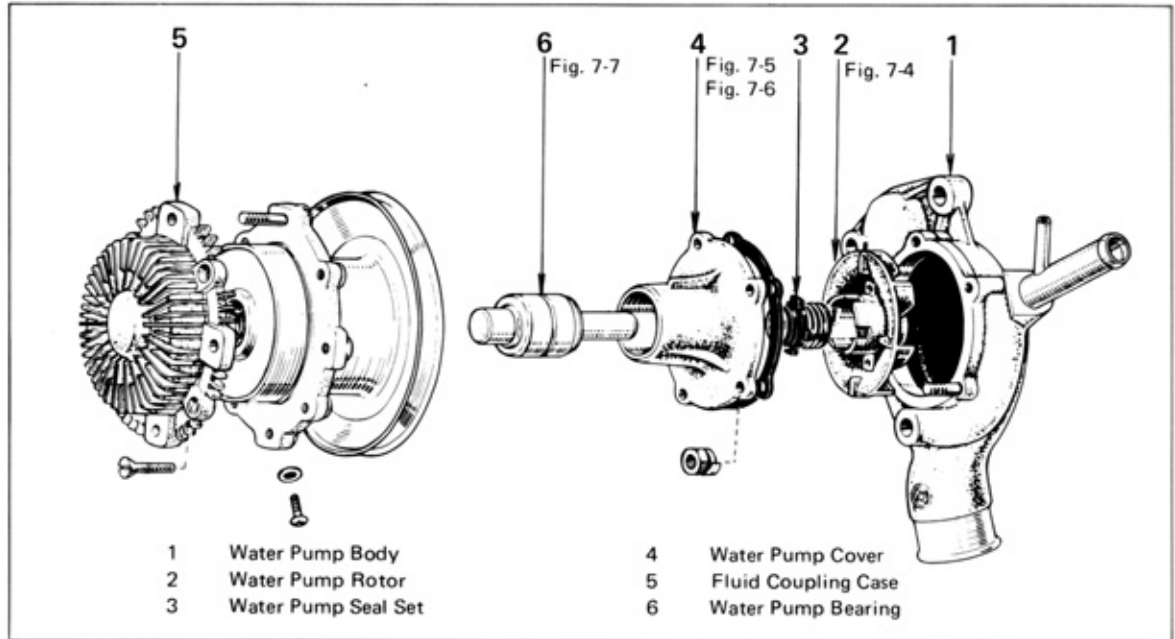
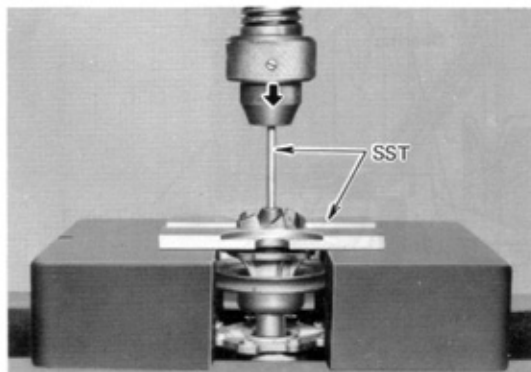
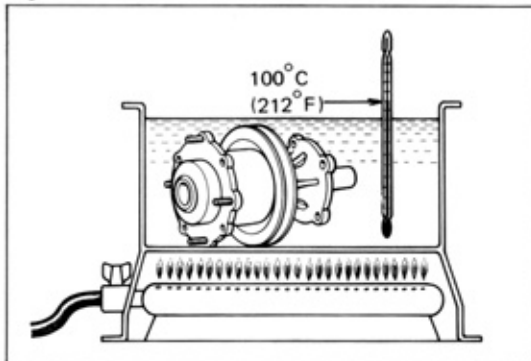


Fig. 7-4



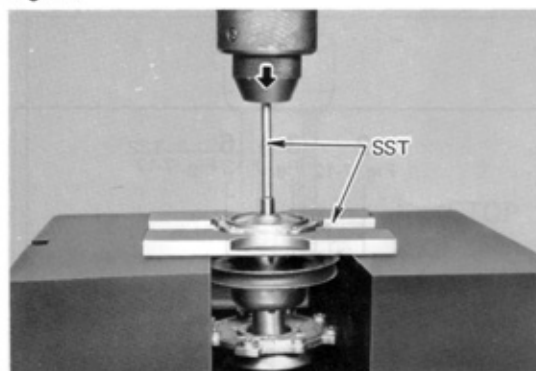
Using SST [09236-36010] and press, remove the rotor.

Fig. 7-5



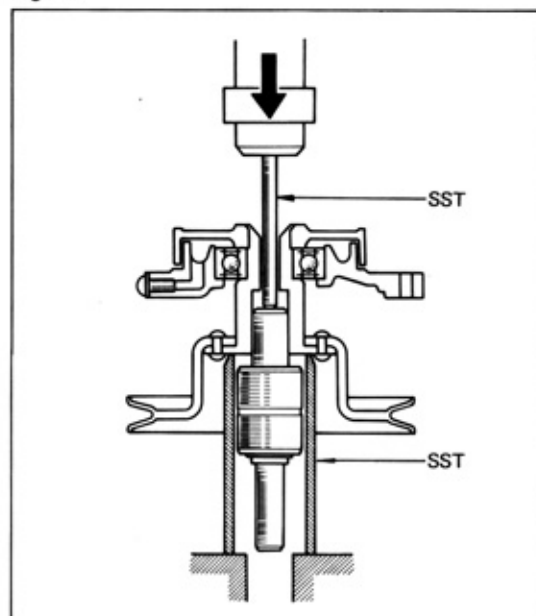
Heat the water pump cover to about 100°C (212°F).

Fig. 7-6



Using SST [09236-36010] and press, force out the bearing from cover.

Fig. 7-7



Using SST [09236-36010] and press, force out the bearing from fluid coupling.

## ASSEMBLY

Assemble in numerical order.

Fig. 7-8

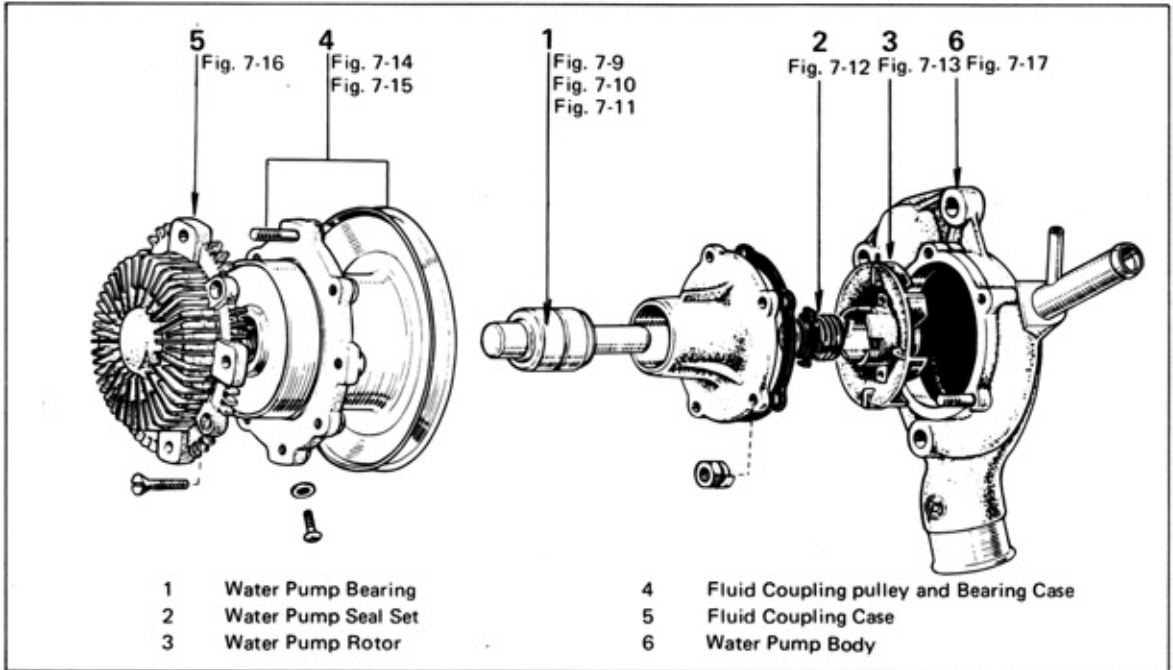
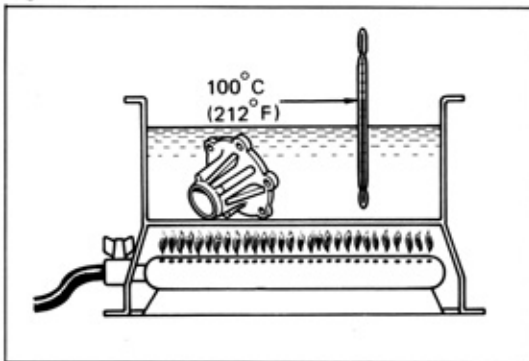
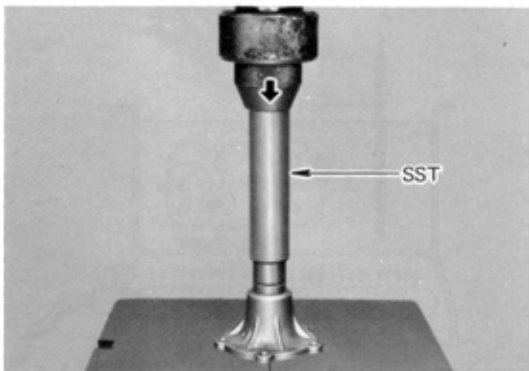


Fig. 7-9



Heat the cover to about 100°C (212°F).

Fig. 7-10

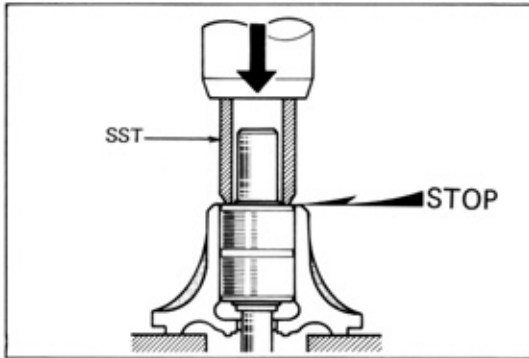


Using SST [09236-36010], press the bearing into the cover.

— caution —

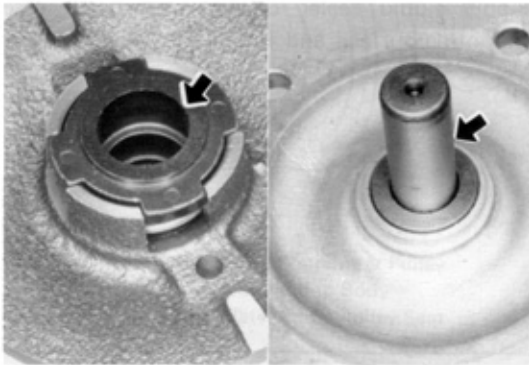
Never press on the bearing shaft.

Fig. 7-11



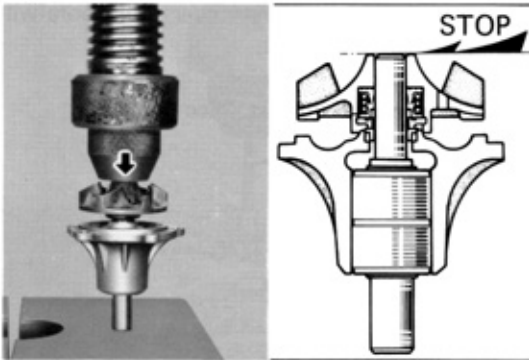
Press in until the bearing end surface is flush with the cover upper surface.

Fig. 7-12



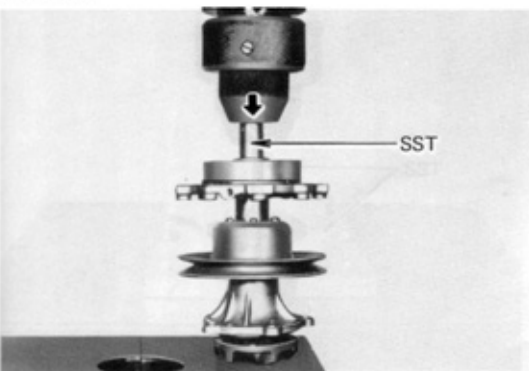
Apply a small amount of silicon oil on contacting surface between the floating seat and the thrust washer, and assemble the seal set.

Fig. 7-13



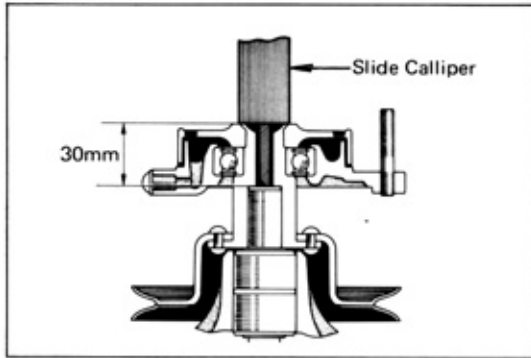
Press the rotor into the bearing shaft, and align the shaft and rotor at top end surface.

Fig. 7-14



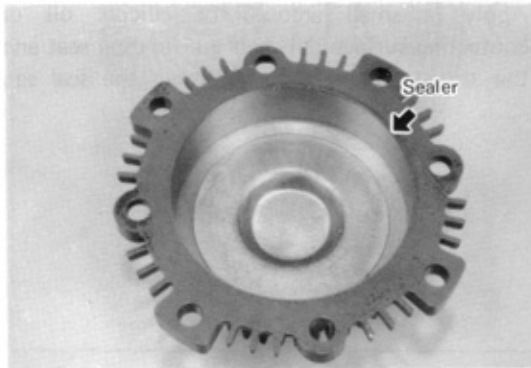
Using SST [09236-36010] and press, install the fluid coupling onto the bearing shaft.

Fig. 7-15



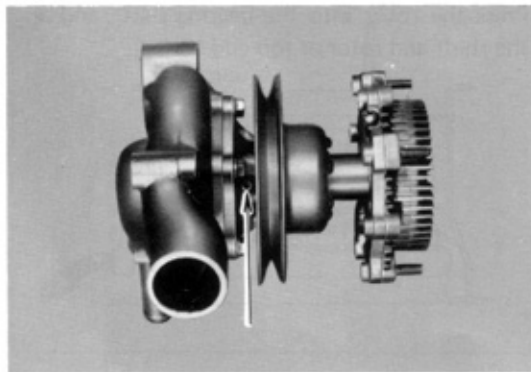
Install the fluid coupling as shown.

Fig. 7-16



Apply liquid sealer on the coupling case mounting surface and install the coupling case.

Fig. 7-17



Install so that the pump cover drain hole will be positioned downward.

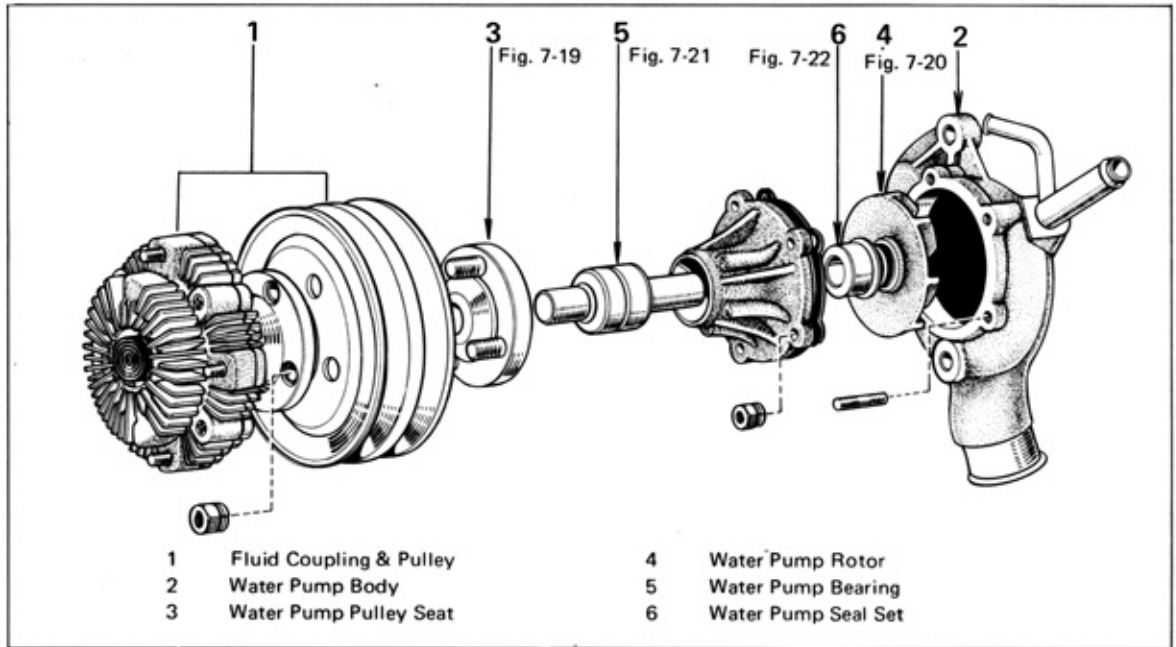
**Applicable Fluid**  
Silicon oil 6,000 cst. 25cc



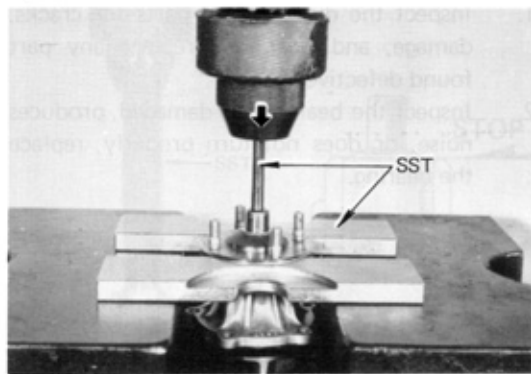
## WATER PUMP(WITH TEMPERED COOLING FAN) DISASSEMBLY

Disassemble in numerical order.

**Fig. 7-18**

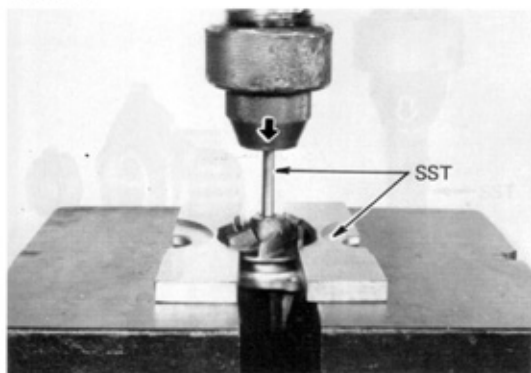


**Fig. 7-19**



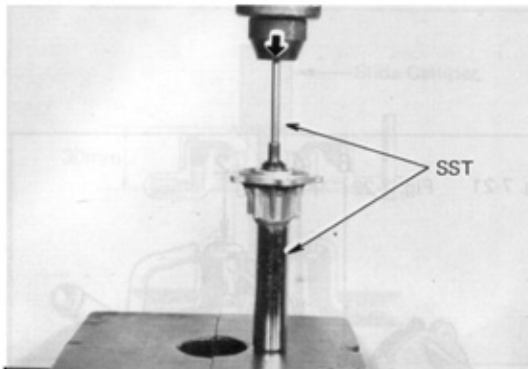
Using SST [09236-36010] and a press, force out the bearing shaft from the pulley seat.

**Fig. 7-20**



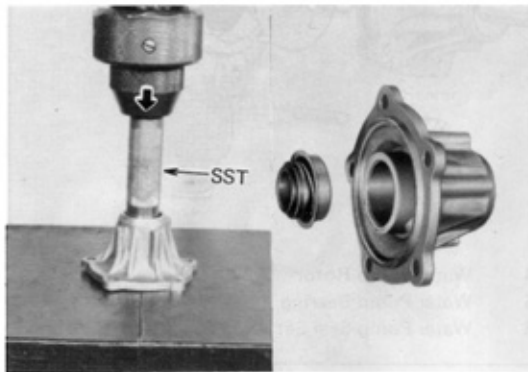
Using SST [09236-36010] and a press, force out the bearing shaft from the rotor.

Fig. 7-21



Heat the water pump cover to about 100°C (212°F), and using SST [09236-36010] and a press, force out the bearing from the pump cover.

Fig. 7-22

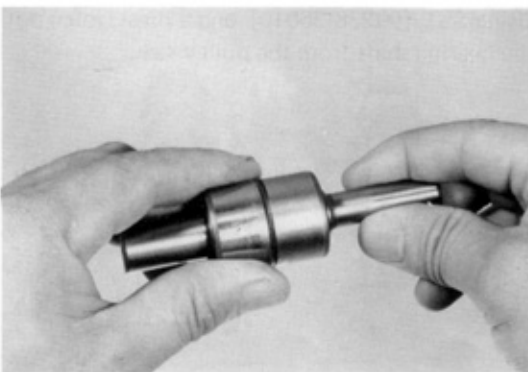


Using a press, force out the seal set from the pump cover.

— Note —

**Force out from the pulley end.**

Fig. 7-23



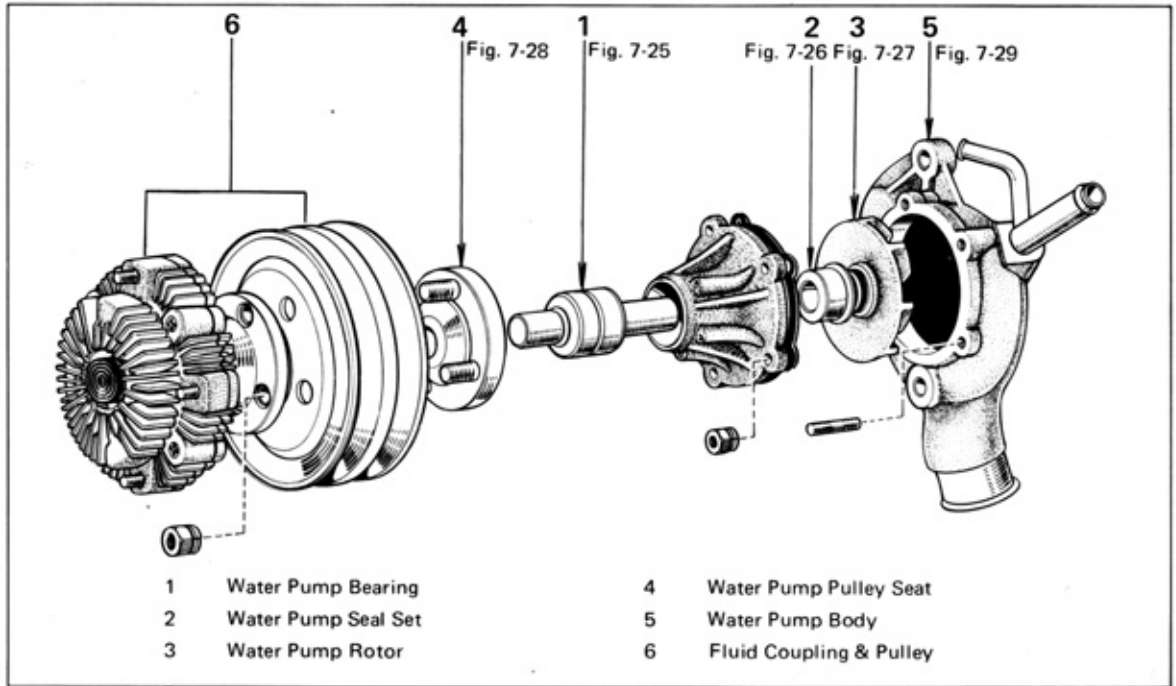
### INSPECTION

1. Inspect the disassembled parts for cracks, damage, and wear, and replace any part found defective.
2. Inspect the bearing. If damaged, produces noise, or does not turn properly, replace the bearing.

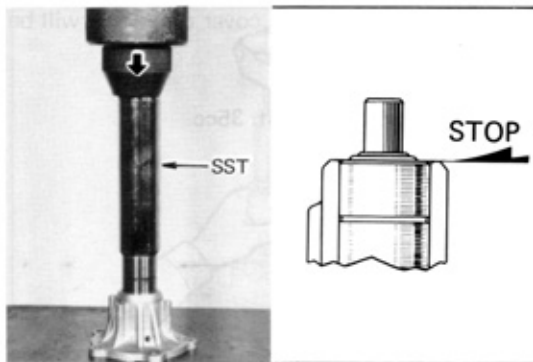
**ASSEMBLY**

Assemble in numerical order.

**Fig. 7-24**



**Fig. 7-25**

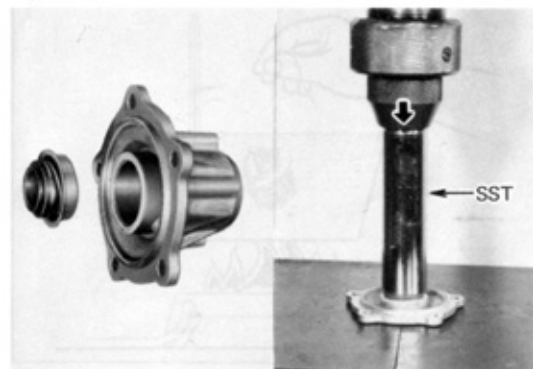


Heat the pump cover to about 100°C (212°F) and force in the bearing with SST [09236-36010] and press.

— Note —

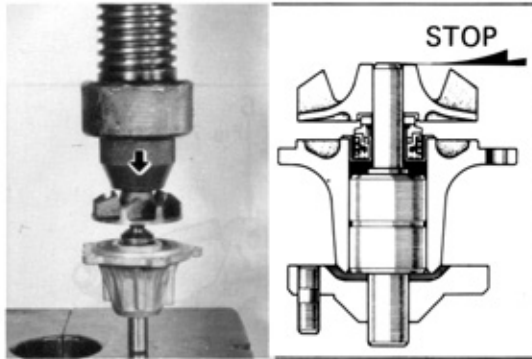
**Press in the bearing until its end surface is flush with cover surface.**

**Fig. 7-26**



Apply liquid sealer on the seal set, and press the seal set into the pump cover.

Fig. 7-27

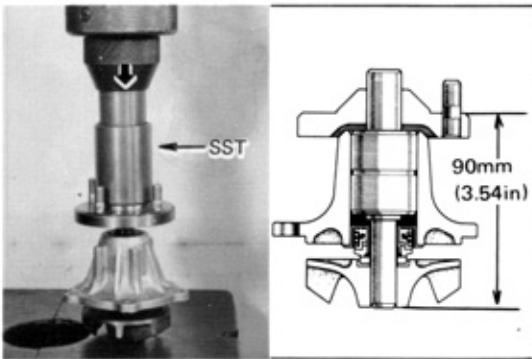


Using a press, force in rotor.

— Note —

Press in the rotor until it is flush with the shaft end.

Fig. 7-28

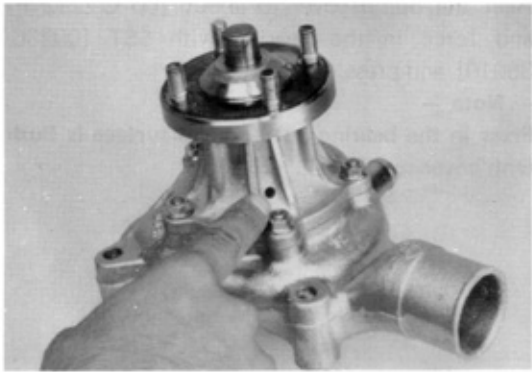


Using a press and SST [09238-40010], force in the pulley seat.

— Note —

Press in the pulley seat until the distance from the bearing shaft end surface to the pulley seat end surface is 90 mm (3.54 in) as shown.

Fig. 7-29



Install so that the pump cover drain hole will be positioned downward.

**Applicable Fluid**

**Silicon oil 3,000 cst. 35cc**

Fig. 7-30

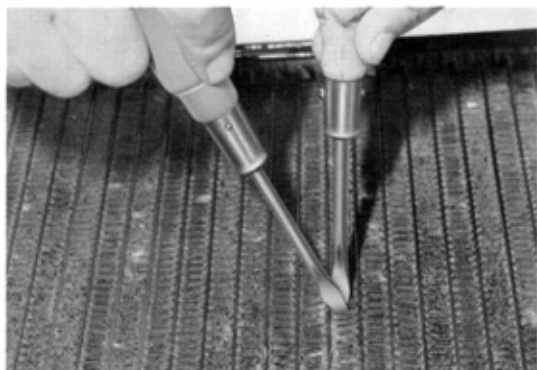


Fig. 7-31

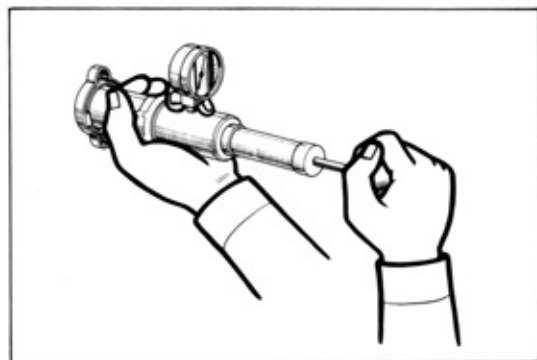


Fig. 7-32

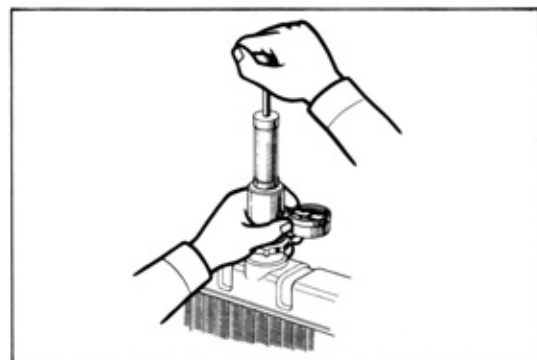
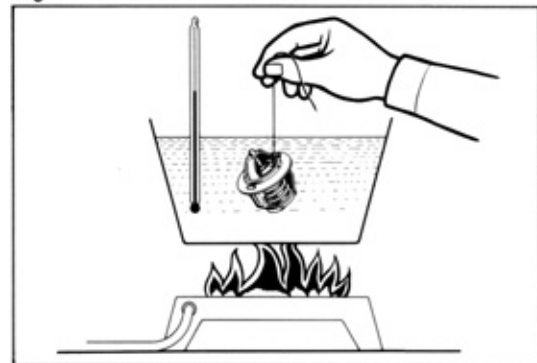


Fig. 7-33



## RADIATOR

### INSPECTION & REPAIR



1. Inspect the radiator core fins, and repair any fins blocking air passage by the method as shown.



2. Inspect the radiator cap regulation pressure and vacuum valves for spring tension and seating. If the pressure gauge drops rapidly and excessively, replace the radiator cap.

**Valve opening pressure limit**

**0.6 kg/cm<sup>2</sup> (8.5 psi)**

**Standard 0.9 kg/cm<sup>2</sup> (12.8 psi)**



3. Inspect the cooling system for leaks. Attach the pressure tester to the radiator and pump it to the specified pressure. If the pressure gauge drops, inspect all hoses and fittings for an external leak. If no external leak is found, an internal intake manifold, block or heater core leak should be suspected.

## THERMOSTAT

### INSPECTION



1. Replace if the valve remains open at normal temperature or does not have proper tightness when fully closed.
2. Immerse the thermostat in the water, and check the valve opening temperatures by heating the water gradually.

The valve is satisfactory if it starts to open at 80.5° to 83.5°C (177° to 182°F) and opens to more than 8 mm (0.32 in) at 95°C (203°F).

Replace if necessary.

MEMO

---