



**TOYOTA  
A40/A41-A43D/A43DE  
AW70 AW71**

**INDEX**

<b>TROUBLE SHOOTING.....</b>	<b>3</b>
<b>DISASSEMBLY.....</b>	<b>5</b>
<b>COMPONENT GROUP INSPECTION.....</b>	<b>11</b>
<b>PUMP .....</b>	<b>12</b>
<b>OVERDRIVE INPUT SHAFT ASSEMBLY.....</b>	<b>15</b>
<b>OVERDRIVE CASE.....</b>	<b>20</b>
<b>FRONT CLUTCH.....</b>	<b>23</b>
<b>REAR CLUTCH.....</b>	<b>27</b>
<b>CENTER SUPPORT.....</b>	<b>29</b>
<b>PLANETARY ASSEMBLY.....</b>	<b>35</b>
<b>CASE ASSEMBLY .....</b>	<b>40</b>
<b>RE-ASSEMBLY AND BEARING LOCATIONS.....</b>	<b>45</b>
<b>VALVE BODY DIFFERENCES AND GASKET I.D.....</b>	<b>56</b>
<b>COMPONENT TECHNICAL CHANGES.....</b>	<b>84</b>
<b>TRANSMISSION IDENTIFICATION .....</b>	<b>95</b>
<b>CHECKBALL LOCATIONS FOR DIFFERENT MODELS..</b>	<b>97</b>

***AUTOMATIC TRANSMISSION SERVICE GROUP***  
**18639 S.W. 107TH AVENUE**  
**MIAMI, FLORIDA 33157**  
**(305) 670-4161**



*Updated  
October, 2002*

## INTRODUCTION

### TOYOTA/VOLVO A40 SERIES

The A40 "*Series*" of transmissions are covered in this manual. In the teardown and assembly section we are using an A43D transmission. We refer to the different valve body configurations where applicable. Although the A40 and A41 do not have the overdrive unit, the assembly is very similar.

The A40 series transmissions are found in Toyota and Volvo vehicles. The units have minor differences and use different gaskets and seals. The Volvo unit may be referred to as the BW55, *Not to be confused with the A55 (Tercel)*. We have illustrated the gaskets for the various valve bodies in a separate section in this manual. This section also shows valve body disassembly.

There have been many gasket and seal changes on these models. We advise you to check the gaskets from the original unit, and compare them with the replacement gaskets to ensure that correct gaskets are installed.

When diagnosing the A40DE, be sure to determine whether it is an electrical complaint or a transmission mechanical complaint, or both. If the computer is not operating, the transmission should be able to shift manually.

No part of any ATSG publication may be reproduced, stored in any retrieval system or transmitted in any form or by any means, including but not limited to electronic, mechanical, photocopying, recording or otherwise, without *written* permission of Automatic Transmission Service Group. This includes all text illustrations, tables and charts.

*We wish to thank the Toyota Motor Company for the information and illustrations that have made this booklet possible.*

*The information and part numbers contained in this booklet have been carefully compiled from industry sources known for their reliability, but ATSG does not guarantee its accuracy.*

**DALE ENGLAND**  
FIELD SERVICE CONSULTANT

**WAYNE COLONNA**  
TECHNICAL SUPERVISOR

**PETER LUBAN**  
TECHNICAL CONSULTANT

**JON GLATSTEIN**  
TECHNICAL CONSULTANT

**JERRY GOTT**  
TECHNICAL CONSULTANT

**GERALD CAMPBELL**  
TECHNICAL CONSULTANT

*Copyright © ATSG 1993*

**JIM DIAL**  
TECHNICAL CONSULTANT

**ED KRUSE**  
TECHNICAL CONSULTANT

**GREGORY LIPNICK**  
TECHNICAL CONSULTANT

**DAVID CHALKER**  
TECHNICAL CONSULTANT

**MIKE SOUZA**  
TECHNICAL CONSULTANT

**ROLAND ALVAREZ**  
TECHNICAL CONSULTANT

***AUTOMATIC TRANSMISSION SERVICE GROUP***  
**18639 S.W. 107TH AVENUE**  
**MIAMI, FLORIDA 33157**  
**(305) 670-4161**



# Technical Service Information

## TROUBLESHOOTING

Problem	Possible cause	Remedy
Fluid discolored or smells burnt	Fluid contaminated Torque converter faulty Transmission faulty	Replace fluid Replace torque converter Disassemble and inspect transmission
Vehicle does not move in any drive range	Manual shift linkage out of adjustment Valve body or primary regulator faulty Parking lock pawl faulty Torque converter faulty Converter drive plate broken Oil pump intake strainer blocked	Adjust shift linkage Inspect valve body Inspect parking pawl Replace torque converter Replace torque converter Clean strainer
Shift lever position incorrect	Manual shift linkage out of adjustment Manual valve and lever faulty Transmission faulty	Adjust shift linkage Inspect valve body Disassemble and inspect transmission
Harsh engagement into any drive range	Throttle cable out of adjustment Valve body or primary regulator faulty Accumulator pistons faulty Transmission faulty	Adjust throttle cable Inspect valve body Inspect accumulator pistons Disassemble and inspect transmission
Delayed 1-2, 2-3 or 3-OD up-shift, or down-shifts from OD-3 or 3-2 then shifts back to OD or 3	Throttle cable out of adjustment Throttle cable and cam faulty Governor faulty Valve body faulty	Adjust throttle cable Inspect throttle cable and cam Inspect governor Inspect valve body
Slips on 1-2, 2-3 or 3-OD up-shift, or slips or shudders on take-off	Manual shift linkage out of adjustment Throttle cable out of adjustment Valve body faulty Transmission faulty	Adjust shift linkage Adjust throttle cable Inspect valve body Disassemble and inspect transmission
Drag, binding or tie-up on 1-2, 2-3 or 3-OD up-shift	Manual shift linkage out of adjustment Valve body faulty Transmission faulty	Adjust shift linkage Inspect valve body Disassemble and inspect transmission



# Technical Service Information

## TROUBLESHOOTING (Cont'd)

Problem	Possible cause	Remedy
Harsh down-shift	Throttle cable out of adjustment Throttle cable and cam faulty Accumulator pistons faulty Valve body faulty Transmission faulty	Adjust throttle cable Inspect throttle cable and cam Inspect accumulator pistons Inspect valve body Disassemble and inspect transmission
No down-shift when coasting	Governor faulty Valve body faulty	Inspect governor Inspect valve body
Down-shift occurs too quick or too late while coasting	Throttle cable out of adjustment Throttle cable faulty Governor faulty Valve body faulty Transmission faulty	Adjust throttle cable Inspect throttle cable Inspect governor Inspect valve body Disassemble and inspect transmission
No OD-3, 3-2 or 2-1 kick-down	Throttle cable out of adjustment Governor faulty Valve body faulty	Adjust throttle cable Inspect governor Inspect valve body
No engine braking in "2" range	Valve body faulty Transmission faulty	Inspect valve body Disassemble and inspect transmission
Vehicle does not hold in "P"	Manual shift linkage out of adjustment Parking lock pawl cam and spring faulty	Adjust shift linkage Inspect cam and spring



# Technical Service Information

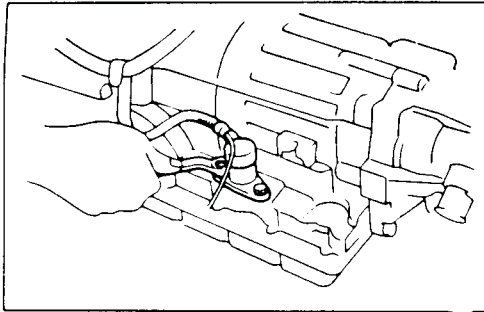

## DISASSEMBLY OF TRANSMISSION SEPARATE BASIC SUBASSEMBLY

REMOVE CLAMP FOR WIRING AND THROTTLE  
CABLE

REMOVE SOLENOID AND O-RINGS

REMOVE SHIFT HANDLE

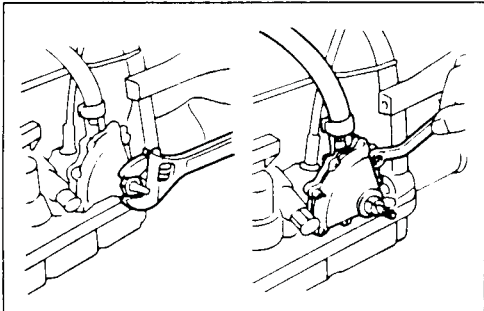

REMOVE NEUTRAL START SWITCH

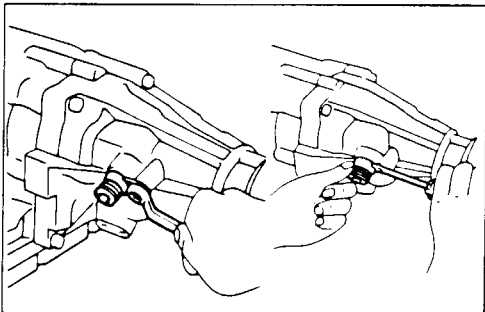

REMOVE SPEEDOMETER DRIVEN GEAR

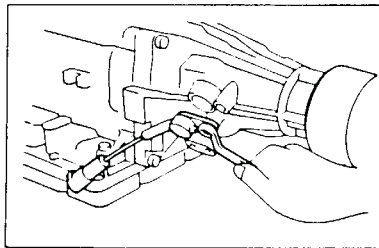

REMOVE SPEED SENSOR

- (a) Disconnect the wiring connector.
- (b) Remove the speed sensor.

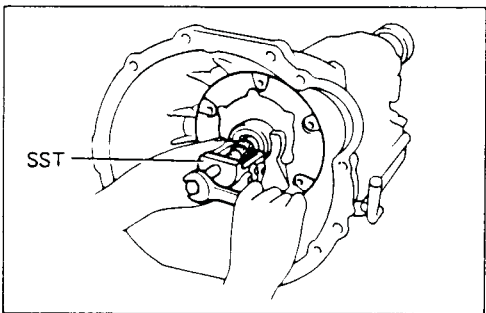

REMOVE OIL PUMP

(a) Remove the seven bolts.

(b) Position SST on the shaft in back of the spline.

SST 09610-20012

**CAUTION:** Do not damage the shaft bushing surface.  
Turn the end bolt of SST to free the pump.

(c) Grasp the front pump stator shaft and pull the pump  
from the case.

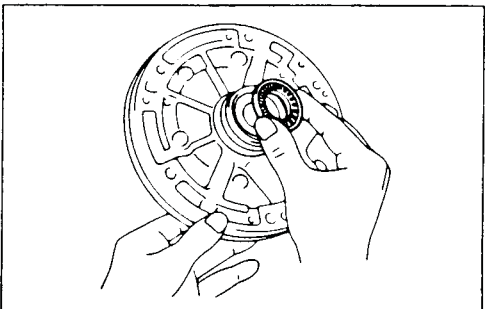

WATCH FOR BEARING BEHIND OIL PUMP



## Technical Service Information

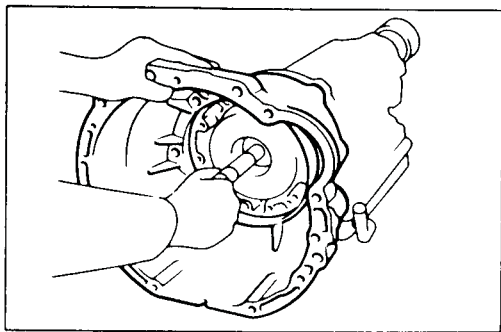

### REMOVE CONVERTER HOUSING AND O-RING

- Remove the two 12-mm bolts and four 10-mm bolts.
- While holding the input shaft, remove the converter housing.

### REMOVE EXTENSION HOUSING AND GASKET

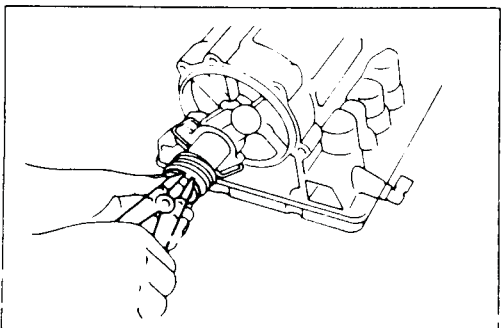

### REMOVE SPEEDOMETER DRIVE GEAR

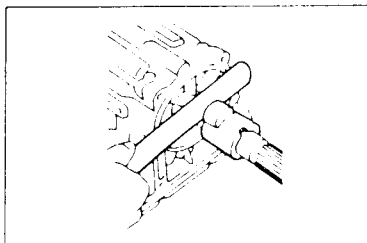

REMOVE SENSOR ROTOR, KEY AND SNAP RING FROM OUTPUT SHAFT

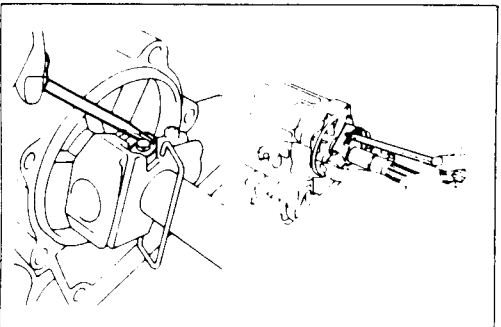

### REMOVE GOVERNOR BODY FROM OUTPUT SHAFT

- Loosen the staked part of the lock plate.
- Remove the governor body lock bolt.
- While lifting the retaining clip with a larger screwdriver, slide off the governor body.

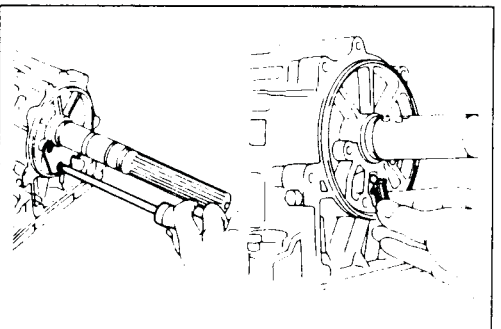

### IF NECESSARY, REMOVE GOVERNOR STRAINER

- Remove the four screws and plate.
- Remove the governor strainer from the case.

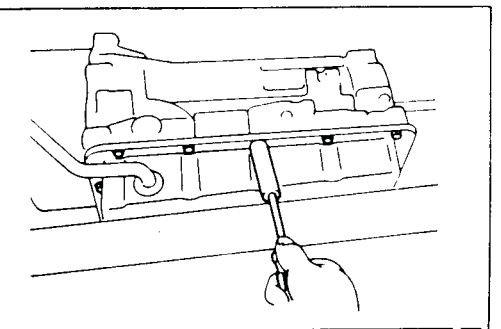

### REMOVE PAN AND GASKET

- Remove the fourteen bolts.
- Remove the pan with lifting the transmission case.

**CAUTION:** Do not turn the transmission over as this will contaminate the valve body with foreign materials in the bottom of the pan.



## Technical Service Information

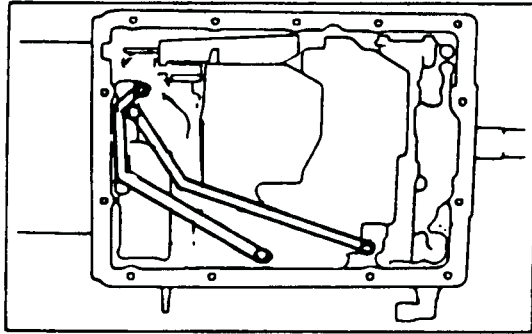

**A40D**

### EXAMINE PARTICLES IN PAN

Remove the magnets and use them to collect any steel chips. Look carefully at the chips and particles in the pan and on the magnets to anticipate what type of wear you will find in the transmission:

- Steel (magnetic) = bearing, gear and clutch plate wear
- Brass (nonmagnetic) = bushing wear.

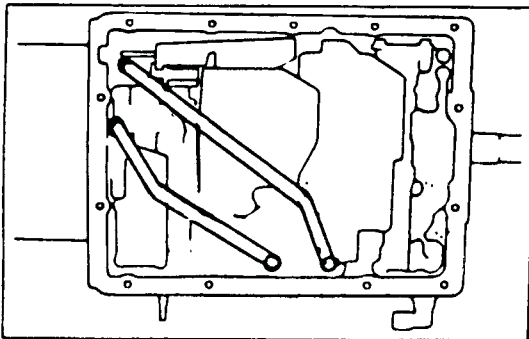

**A42D  
A43D**

### TURN TRANSMISSION OVER AND REMOVE TUBES

Pry up both tube ends with a large screwdriver and remove the tubes.

### REMOVE STRAINER AND GASKET

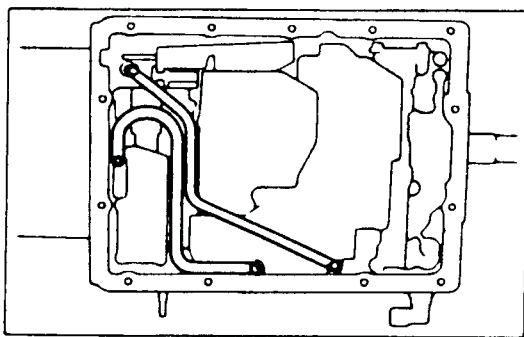

**A43DL  
A44DL  
A45DL**

### REMOVE VALVE BODY

- (a) Remove the seventeen bolts.

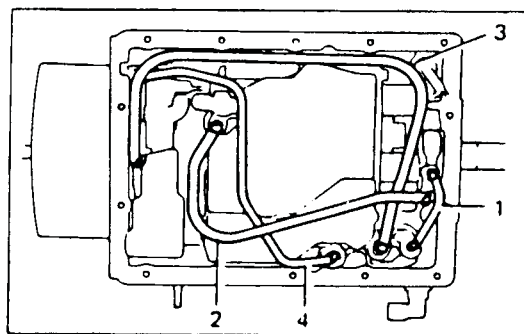

**A43DE  
A46DE**

- (b) Disconnect the throttle cable from the cam and remove the valve body.

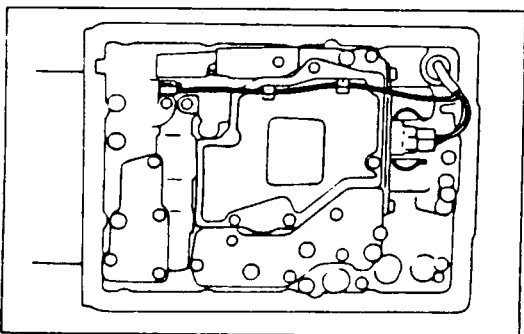

### REMOVE SOLENOID WIRING

- (a) Disconnect connector from the No. 1 and 2 solenoid and the No. 3 solenoid.
- (b) Remove the grommet from the transmission case.
- (c) Pull the wiring out of the transmission case.



## Technical Service Information

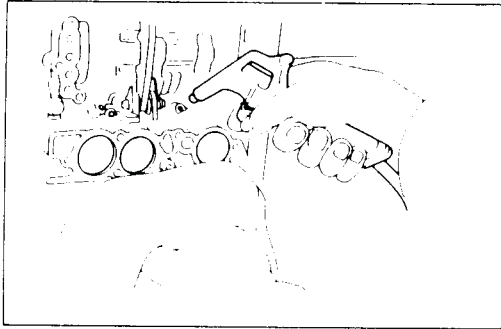

### COVER PISTON WITH A RAG AND, REMOVE ACCUMULATOR PISTONS AND SPRINGS

**WARNING:** Keep your face away to avoid injury. Do not use regular high-pressure air.

Position a rag to catch each piston. Using low-pressure compressed air (1 kg/cm<sup>2</sup>, 14 psi or 98 kPa, max.), pop each piston into the rag. Force air into the holes shown, and remove the pistons and springs.

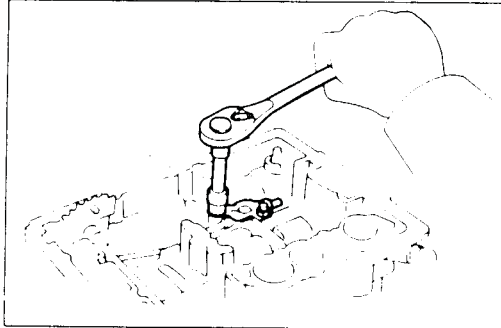

### REMOVE PARKING LOCK ROD

REMOVE SPRING, PIVOT PIN AND PARKING LOCK PAWL

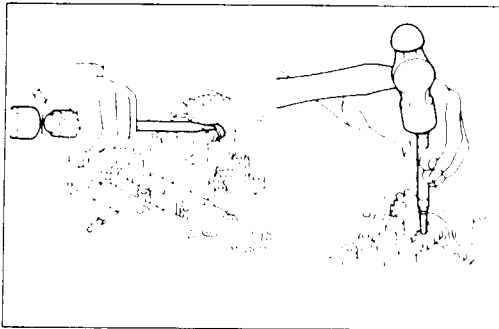

### IF NECESSARY REMOVE MANUAL LEVER AND SHAFT

- Using a hammer and screwdriver, pry and shift the collar.
- Using a hammer and punch, drive out the pin.
- Slide the shaft out case and remove the detent plate.

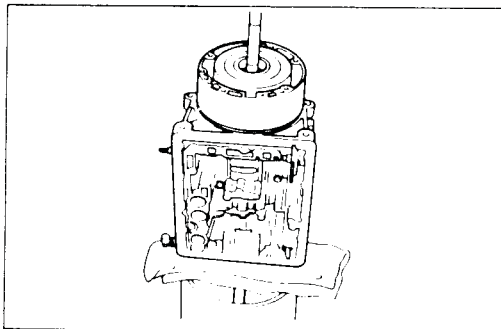

### PLACE TRANSMISSION CASE ON CYLINDER

Place the transmission on a cylindrical stand for more efficient work.

**CAUTION:** Place shop rags between the case and stand to avoid damaging the case.

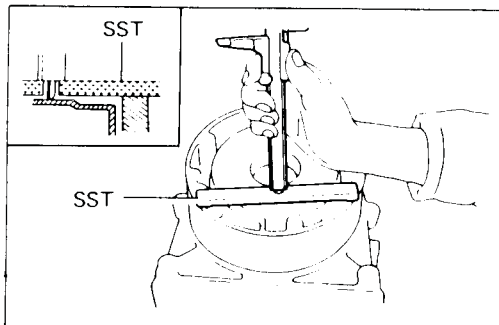

### MEASURE DISTANCE BETWEEN TOP OF CASE AND CLUTCH DRUM

Set SST on the case as shown in the figure.

SST 09350-20013

Make a note of the distance for reassembly.





## Technical Service Information

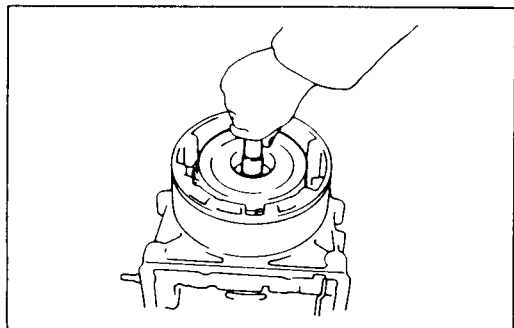

### REMOVE OVERDRIVE CLUTCH

Grasp the shaft and pull out the overdrive clutch assembly. Watch for bearings and races on both sides of the assembly.

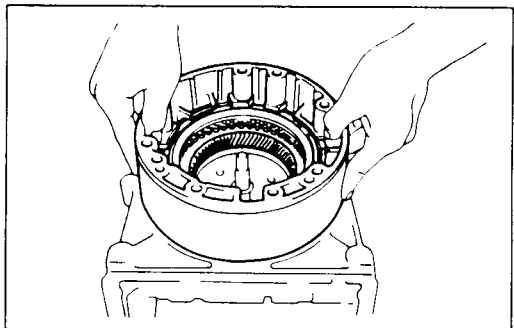

### REMOVE OVERDRIVE CASE AND BRAKE

Hold both sides of the overdrive case and pull it out from the transmission case. Watch for bearings and races on both sides of the assembly.

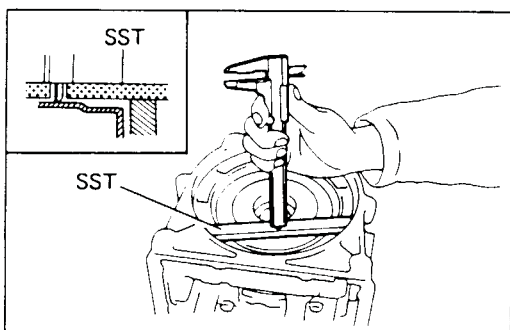

### MEASURE DISTANCE BETWEEN TOP OF CASE FLANGE AND CLUTCH DRUM

Set SST in the case as shown in the figure.

SST 09350-20013

Make a note of the finding for reassembly.

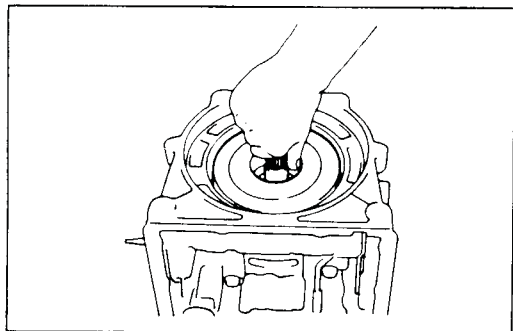

### REMOVE FRONT CLUTCH AND BEARINGS

Grasp the shaft and pull out the front clutch assembly. Watch for bearings and races on both sides of the assembly.

### REMOVE BEARING AND RACE

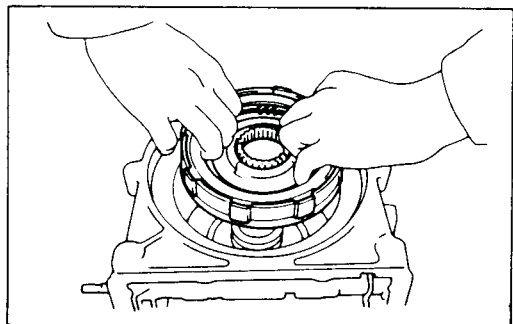

### REMOVE REAR CLUTCH

Grasp the clutch hub and pull it out from the case.



## Technical Service Information

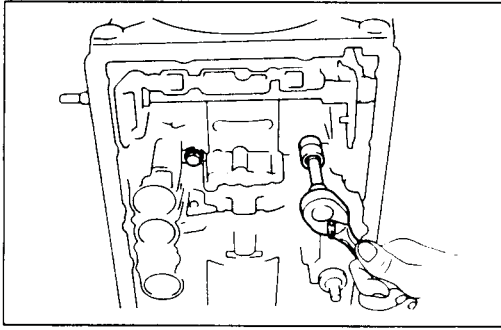

### REMOVE CENTER SUPPORT AND SUN GEAR

(a) Remove the two center support bolts.

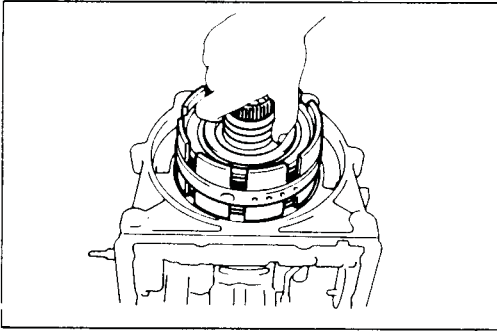

(b) Grasp the assembly and pull out the center support with the sun gear.

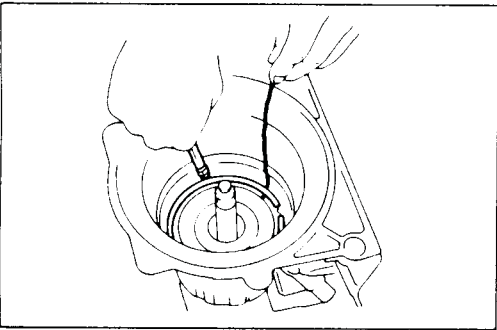

### REMOVE REACTION PLATE RETAINING RING

Using a long screwdriver, compress the snap ring and then lift it above the groove with a wire hook.

### REMOVE REAR PARTS GROUP

Grasp the intermediate shaft and pull out the rear parts group.

If the brake apply tube and rear thrust bearing and races do not come out with the assembly, remove them from the case.

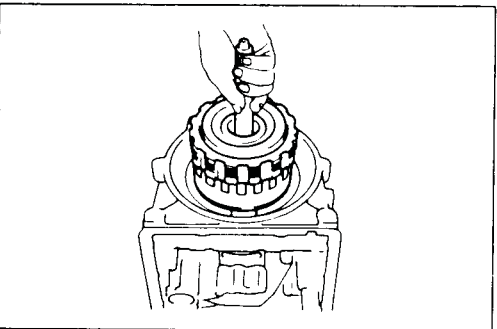

### BASIC DISASSEMBLY IS COMPLETE

The transmission is now in basic component subassemblies. Next, you will disassemble, clean, inspect, repair and assemble each of these component groups.



## COMPONENT GROUP DISASSEMBLY, INSPECTION AND ASSEMBLY

The instructions here are organized so that you work on only one component group at a time. This will help avoid confusion of similar-looking parts from different subassemblies being on your workbench at the same time.

The component groups are inspected and repaired from the converter housing side.

As much as possible, complete the inspection, repair, assembly before proceeding to the next component group. If a component group cannot be assembled because parts are being ordered, be sure to keep all parts of that group in a separate container while proceeding with disassembly, inspection, repair and assembly of other component groups.

### GENERAL CLEANING

All disassembled parts should be washed clean and the fluid passages and holes blown through with compressed air to make sure that they are not clogged.

When using compressed air to dry parts, keep face away to avoid spraying solvent in your face.

Cleaning solvent used should be the recommended ATF or kerosene.

### PARTS ARRANGEMENT

After cleaning, the parts should be arranged in proper order to allow performing the inspection, repairs, and reassembly with efficiency.

When disassembling a valve body, be sure to keep each valve together with the corresponding spring.

New brakes and clutches that are to be used for replacement must be soaked in transmission fluid for at least two hours before assembly.

### GENERAL ASSEMBLY

All oil seal rings, clutch discs, clutch plates, rotating parts, and sliding surfaces should be coated with transmission fluid prior to reassembly.

All gaskets and rubber O-rings should be replaced.

Make sure that the ends of a snap ring are not aligned with one of the cutouts and are installed in the groove correctly.

If a worn bushing is to be replaced, the replacement must be made with the subassembly containing that bushing.

Check thrust bearings and races for wear or damage. Replace if necessary.

Use petroleum jelly to keep parts in place.

# Technical Service Information

## Oil Pump

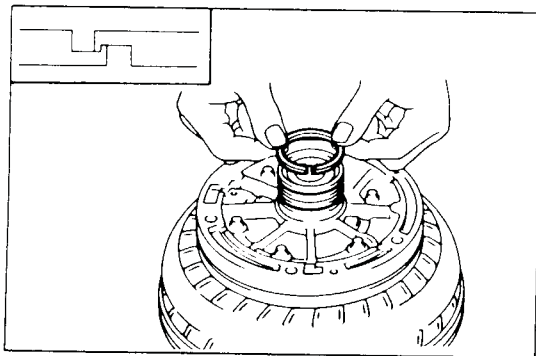
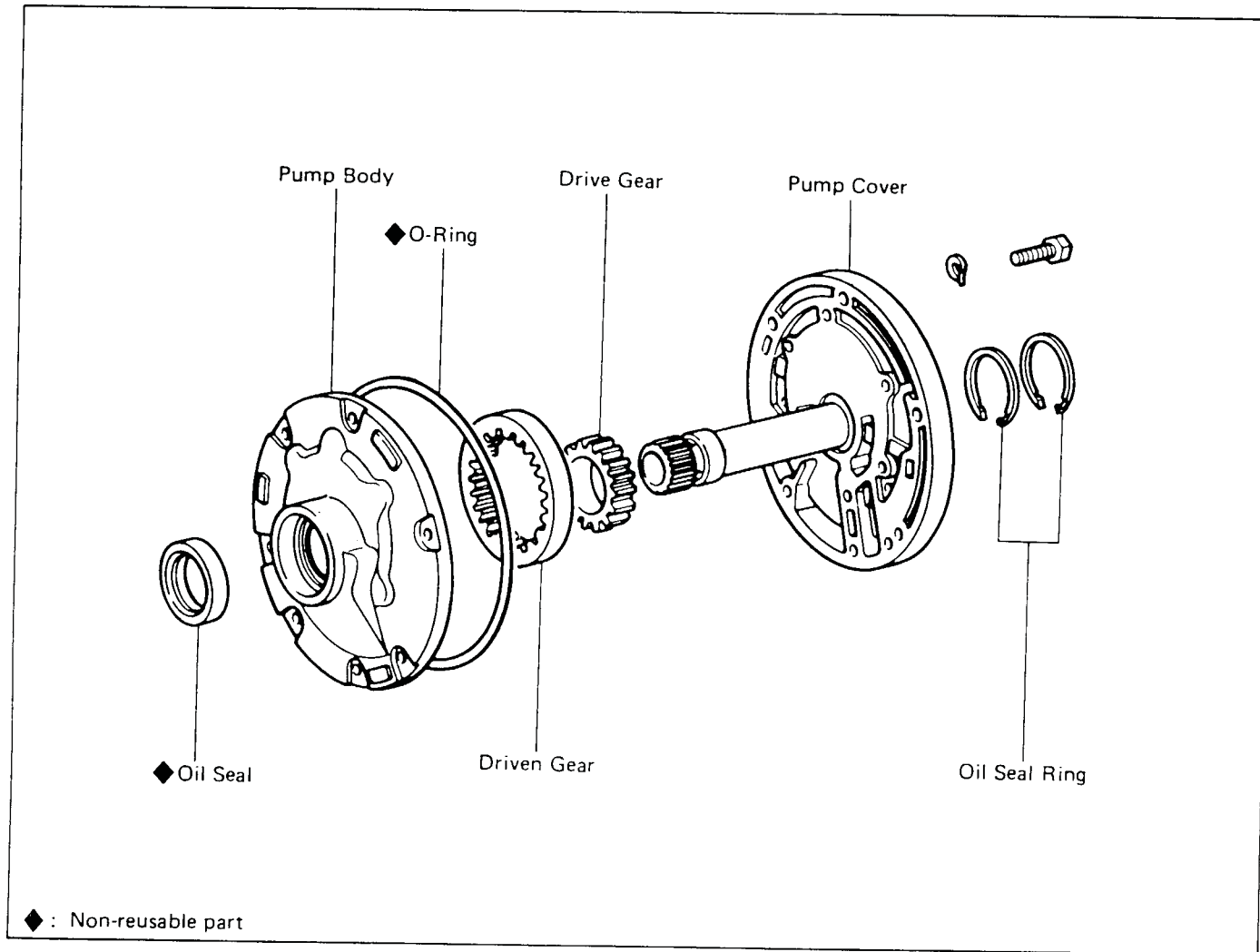

### DISASSEMBLY OF OIL PUMP

USE TORQUE CONVERTER AS A WORK STAND

REMOVE TWO OIL SEAL RINGS FROM PUMP COVER

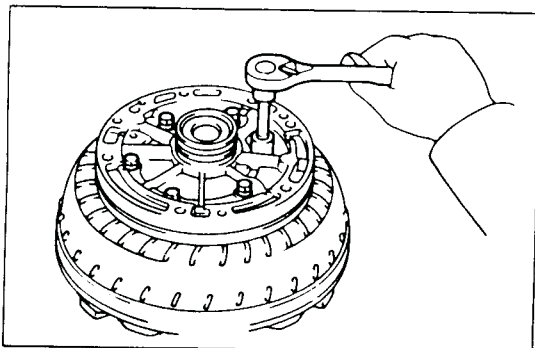

REMOVE PUMP COVER

REMOVE O-RING FROM PUMP

LIFT PUMP OFF CONVERTER AND REMOVE OIL PUMP  
DRIVE GEAR AND DRIVEN GEAR

Identify the top and bottom and keep in assembly order.



# Technical Service Information

## INSPECTION OF OIL PUMP

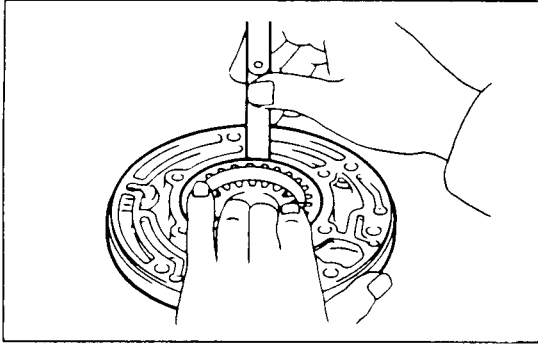

### CHECK BODY CLEARANCE OF DRIVEN GEAR

Push the driven gear to one side of the body. Using a feeler gauge, measure the clearance.

Standard body clearance: 0.07 – 0.15 mm  
(0.0028 – 0.0059 in.)

Maximum body clearance: 0.3 mm (0.012 in.)

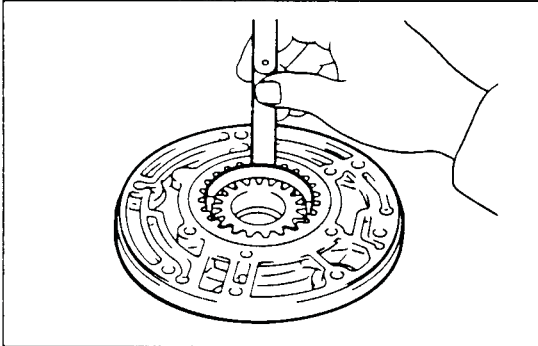

### CHECK TIP CLEARANCE OF BOTH GEARS

Measure between the gear teeth and the crescent-shaped part of the pump body.

Standard tip clearance: 0.11 – 0.14 mm  
(0.0043 – 0.0055 in.)

Maximum tip clearance: 0.3 mm (0.012 in.)

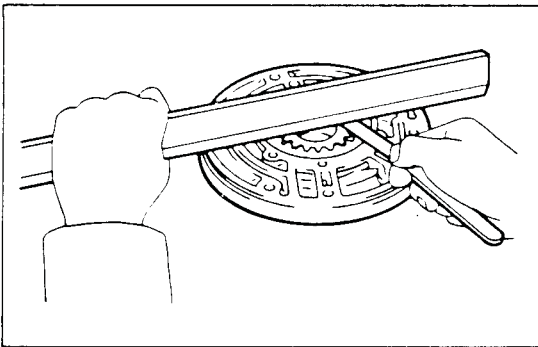

### CHECK SIDE CLEARANCE OF BOTH GEARS

Using a steel straightedge and a feeler gauge, measure the side clearance of both gears.

Standard side clearance: 0.02 – 0.05 mm  
(0.0008 – 0.0020 in.)

Maximum side clearance: 0.1 mm (0.004 in.)

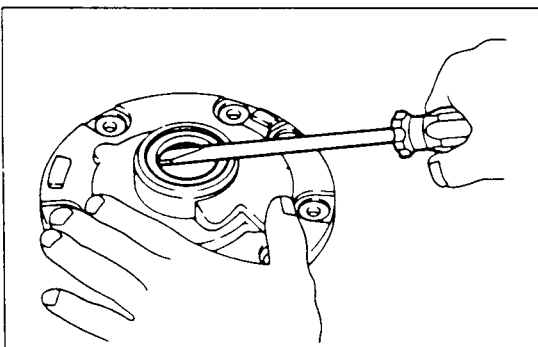

### INSPECT FRONT OIL SEAL

Check for wear, damage or cracks.

### IF NECESSARY, REPLACE FRONT OIL SEAL

(a) Pry off the oil seal with a screwdriver.

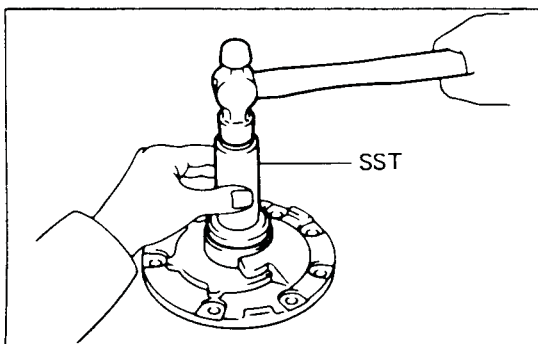

(b) Using SST and a hammer, install a new oil seal. The seal end should be flush with the outer edge of the pump body.

SST 09350-20013



# Technical Service Information

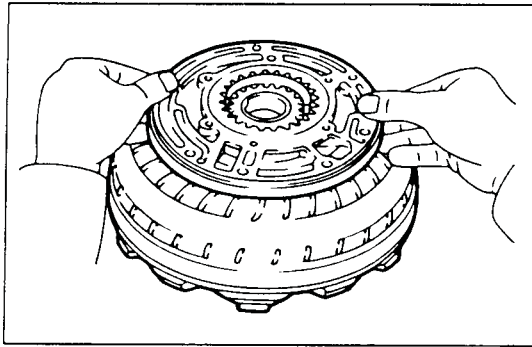

## ASSEMBLY OF OIL PUMP

### INSTALL DRIVEN GEAR AND DRIVE GEAR AND SET PUMP BODY ON TORQUE CONVERTER

Make sure the top of the gears is facing upward.

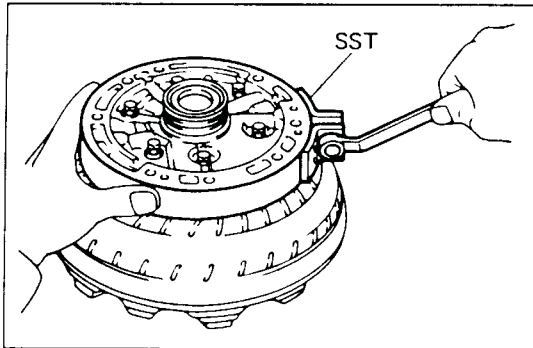

### LOOSELY INSTALL PUMP COVER

Align the bolt holes and drop the pump cover into place. Install the six bolts with wave washers finger tight.

### ALIGN PUMP AND PUMP COVER

Install the SST around the pump and cover. Tighten SST to align the pump and cover.

SST 09350-20013

### TIGHTEN SIX PUMP COVER BOLTS

Torque: 75 kg-cm (65 in.-lb, 7.4 N·m)

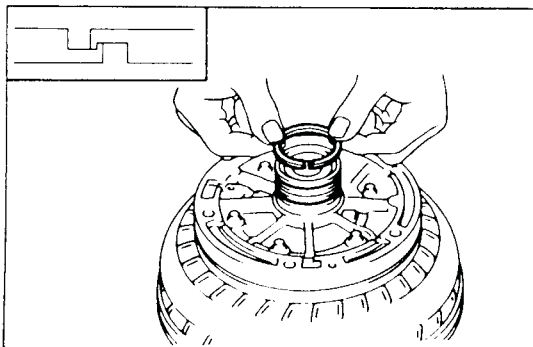

### INSTALL TWO OIL SEAL RINGS ON PUMP COVER

Spread the rings apart and slide them into the groove. Hook both ends by hand. Wipe off excess petroleum jelly.

### INSTALL NEW O-RING ON PUMP COVER

Make sure a new O-ring is not twisted and is fully seated in the groove.

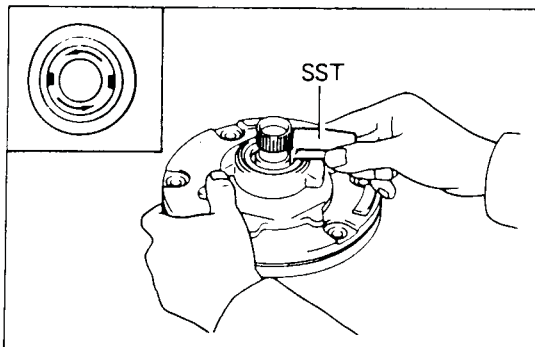

### CHECK PUMP DRIVE GEAR ROTATION

Turn the drive gear with SST and make sure that it rotates smoothly.

SST 09350-20013



## Overdrive Input Shaft and Clutch

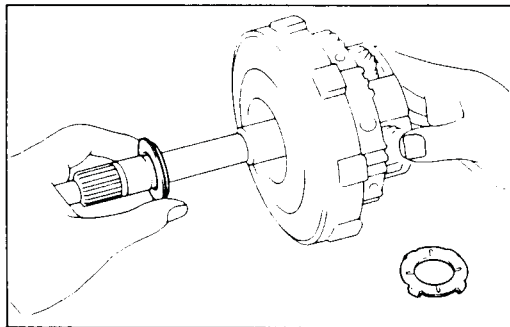
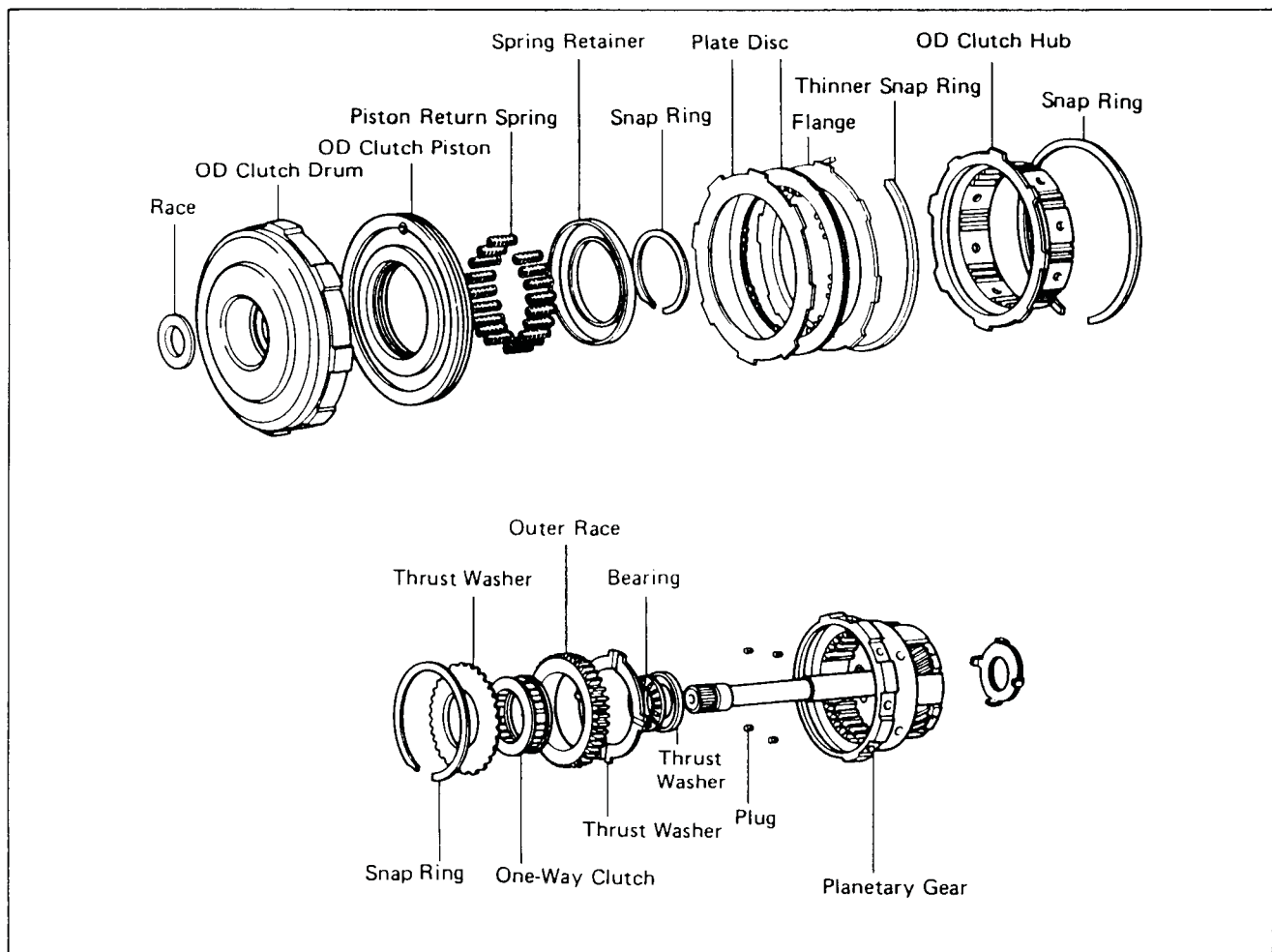

### DISASSEMBLY OF OVERDRIVE INPUT SHAFT AND CLUTCH

#### REMOVE THRUST BEARINGS AND RACES FROM OVERDRIVE INPUT SHAFT

- Slide off the thrust bearing and race from the clutch side by hand. Note the position of the races.
- Using a screwdriver, pry off the thrust washer from the planetary gear side.

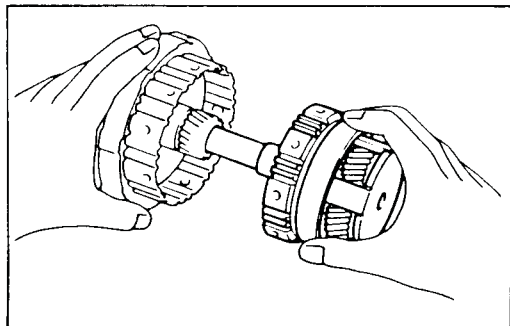

#### PULL OVERDRIVE CLUTCH ASSEMBLY FROM INPUT SHAFT

**CAUTION:** Be careful that the thrust bearing and race do not fall out.

#### REMOVE THRUST BEARING AND RACE

Note the position of the race.



## Technical Service Information

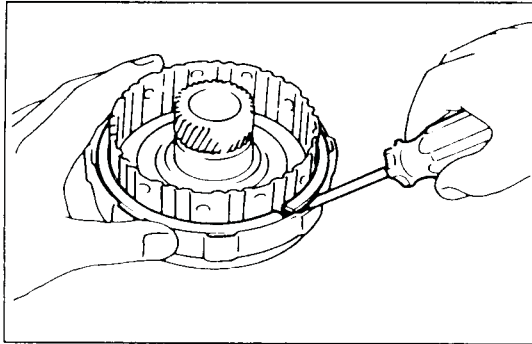

**REMOVE SNAP RING AND HUB FROM OVERDRIVE CLUTCH ASSEMBLY**

**REMOVE THINNER SNAP RING, FLANGE, DISC AND PLATE**

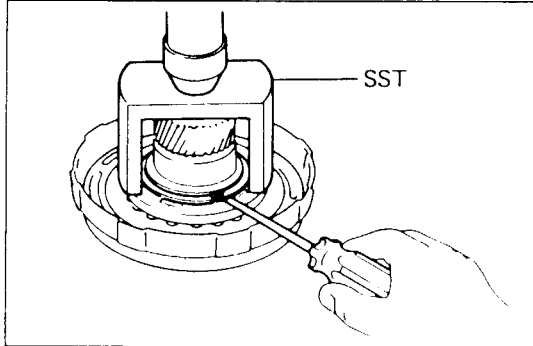

**COMPRESS PISTON RETURN SPRINGS AND REMOVE SNAP RING**

Place SST on the spring retainer and compress the springs with a shop press. Using a screwdriver, remove the snap ring.

SST 09350-20013

**REMOVE SPRING RETAINER AND EIGHTEEN SPRINGS**

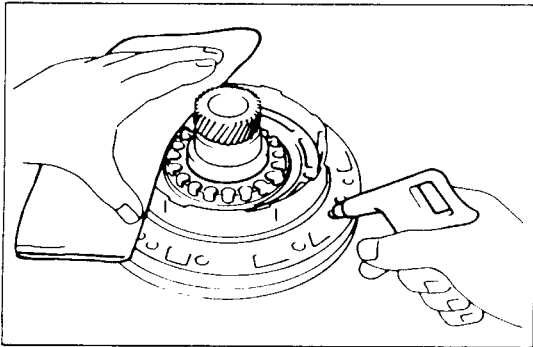

**ASSEMBLE OVERDRIVE CLUTCH ON OIL PUMP AND BLOW OUT PISTON**

- Slide the overdrive clutch onto the oil pump.
- Apply compressed air to the oil pump to remove the piston. (If the piston does not come out completely, use needle-nose pliers to remove it.)
- Remove the overdrive clutch from the oil pump.

**REMOVE CLUTCH PISTON O-RINGS**

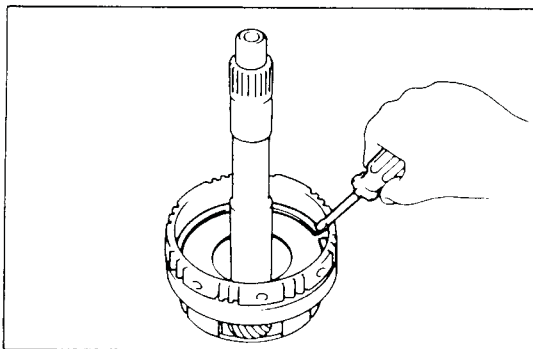

**REMOVE SNAP RING FROM OVERDRIVE PLANETARY GEAR ASSEMBLY**

**REMOVE THRUST WASHERS AND ONE-WAY CLUTCH FROM PLANETARY GEAR ASSEMBLY**

**CAUTION:** Be careful not to lose the four plugs.

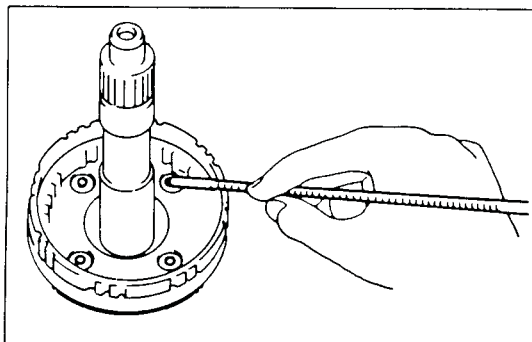

**REMOVE FOUR PLUGS WITH MAGNETIC FINGER**

**CAUTION:** Keep the four plugs together to prevent losing them.





## Technical Service Information

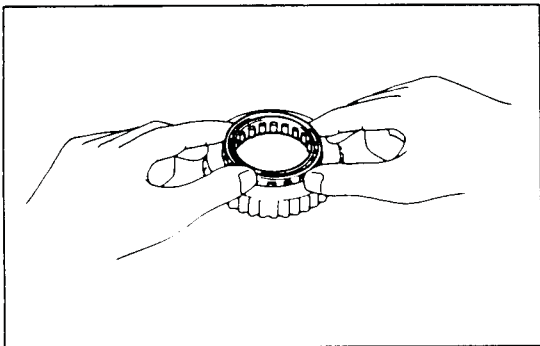

### REMOVE ONE-WAY CLUTCH FROM OUTER RACE

Note the direction of the one-way clutch.

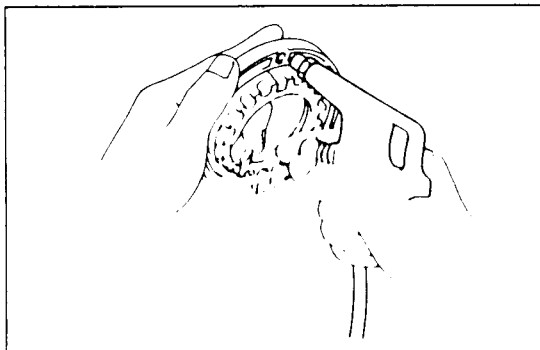

### INSPECTION OF OVERDRIVE INPUT SHAFT AND CLUTCH

#### INSPECT CLUTCH PISTON

- (a) Check that check ball is free by shaking the piston.
- (b) Check that the valve does not leak by apply low-pressure compressed air.

NOTE: Do not allow the discs to dry out. Prepare new discs by soaking them at least two hours in ATF.

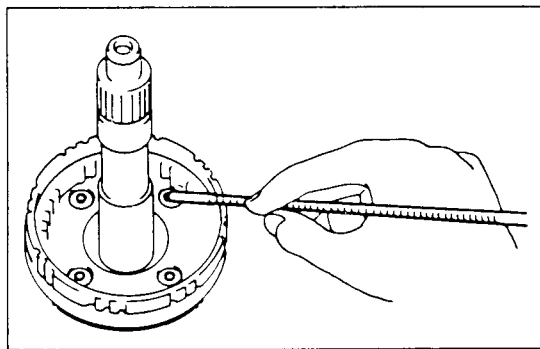

### ASSEMBLY OF OVERDRIVE INPUT SHAFT AND CLUTCH

#### INSTALL FOUR PLUGS

#### INSTALL THRUST WASHER AND BEARING

- (a) Coat parts with petroleum jelly to hold them in place.
- (b) Slide bearing and then thrust washer facing lip outward.

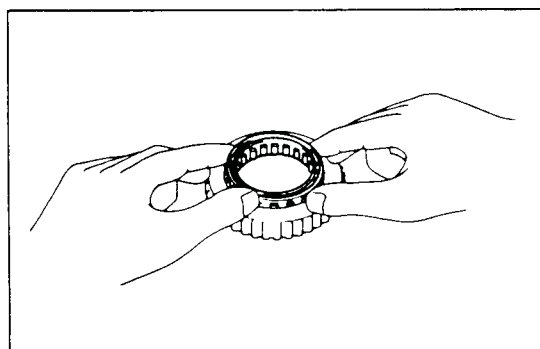

#### ASSEMBLE ONE-WAY CLUTCH

- (a) Install the one-way clutch into the outer race.
- (b) Install a retainer on both sides of the one-way clutch.

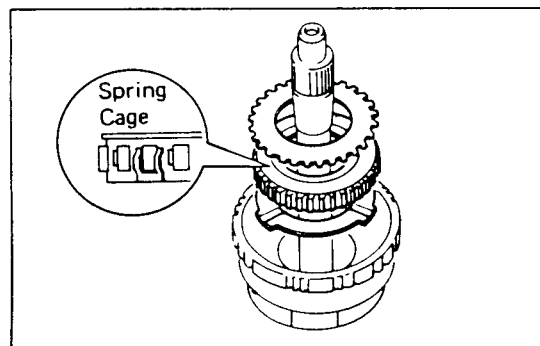

#### INSTALL THRUST WASHER AND ONE-WAY CLUTCH

- (a) Install the thrust washer, facing the grooves upward.
- (b) Install the one-way clutch in correct direction.
- (c) Install the thrust washer.
- (d) Install the snap ring.

NOTE: Be sure that the spring cage side of the one-way clutch faces toward the front of the transmission.



## Technical Service Information

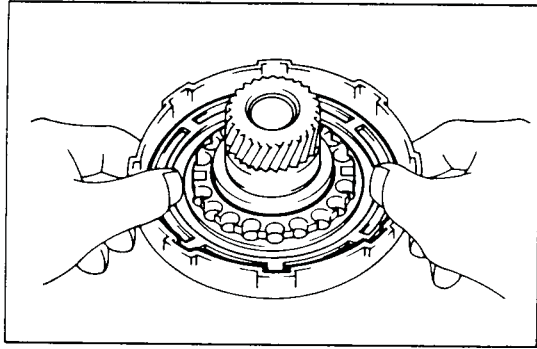

### INSTALL CLUTCH PISTON IN OVERDRIVE CLUTCH DRUM

- Install new O-rings on the piston. Coat the O-rings with ATF.
- Press the piston into the drum with the cup side up, being careful not to damage the O-ring.

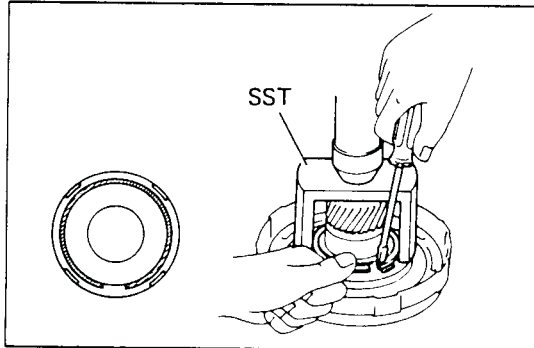

### INSTALL EIGHTEEN PISTON RETURN SPRINGS AND SET RETAINER AND SNAP RING IN PLACE

#### COMPRESS RETURN SPRINGS AND INSTALL SNAP RING IN GROOVE

- Place SST on the spring retainer, and compress the springs on a shop press.

SST 09350-20013

- Install the snap ring with a screwdriver.

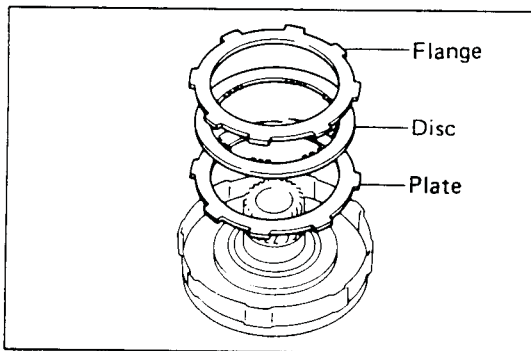

### INSTALL PLATE, DISC AND FLANGE WITHOUT ASSEMBLING THINNER SNAP RING

- Do not assemble the thinner snap ring yet.
- Using low-pressure compressed air, blow all excess ATF from the disc.

**CAUTION:** High-pressure air will damage the disc.

Install in order: Plate-disc-flange (flat end down)

### CHECK PISTON STROKE OF OVERDRIVE CLUTCH

- Install the overdrive clutch hub and outer snap ring.
- Install the front clutch drum onto the oil pump body. With a dial indicator, measure the stroke applying and releasing the compressed air (4 – 8 kg/cm<sup>2</sup>, 57 – 114 psi or 392 – 785 kPa) as shown.

Standard piston stroke: 1.47 – 2.28 mm  
(0.0579 – 0.0898 in.)

If the stroke exceeds limit, the clutch pack is probably worn. If the stroke is less than the limit, parts may be misassembled or there may be excess ATF on the discs.

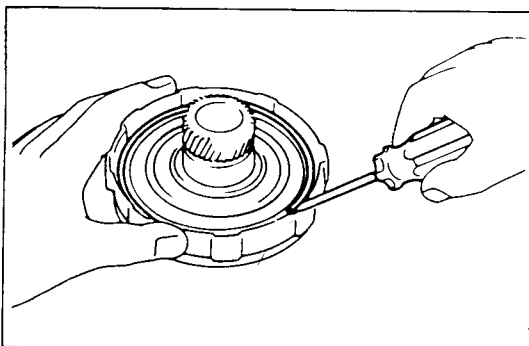
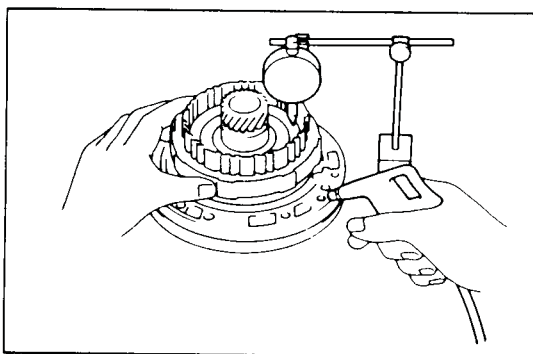

### INSTALL THINNER SNAP RING IN OVERDRIVE CLUTCH DRUM

- Remove the overdrive clutch outer snap ring and hub to allow installation of the thinner snap ring.
- Compress and lower the snap ring into the groove by hand. Check that the ends of the snap ring are not aligned with one of the cutouts.



## Technical Service Information

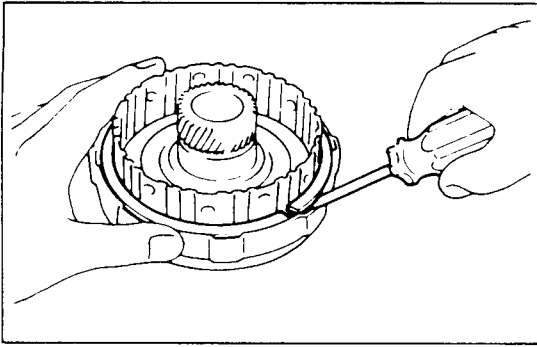

### INSTALL HUB AND OUTER SNAP RING

Check that the ends of the snap ring are not aligned with one of the cutouts.

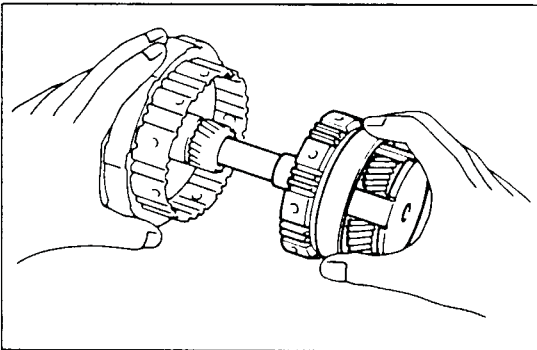

### ASSEMBLE OVERDRIVE CLUTCH DRUM AND OVERDRIVE PLANETARY GEAR

Mesh the hub with the disc, twisting and jiggling the hub as required.

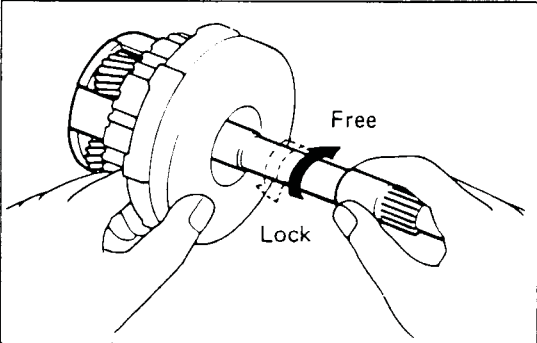

### CHECK OPERATION OF ONE-WAY CLUTCH

Hold the clutch drum and turn the input shaft. The input shaft should turn freely clockwise and should lock counterclockwise.

### KEEP THRUST WASHER, THRUST BEARINGS AND RACE TOGETHER



## Overdrive Case and Brake

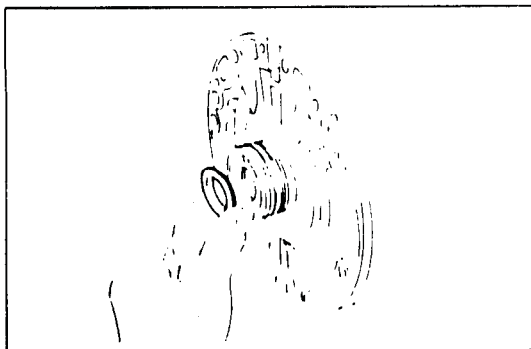
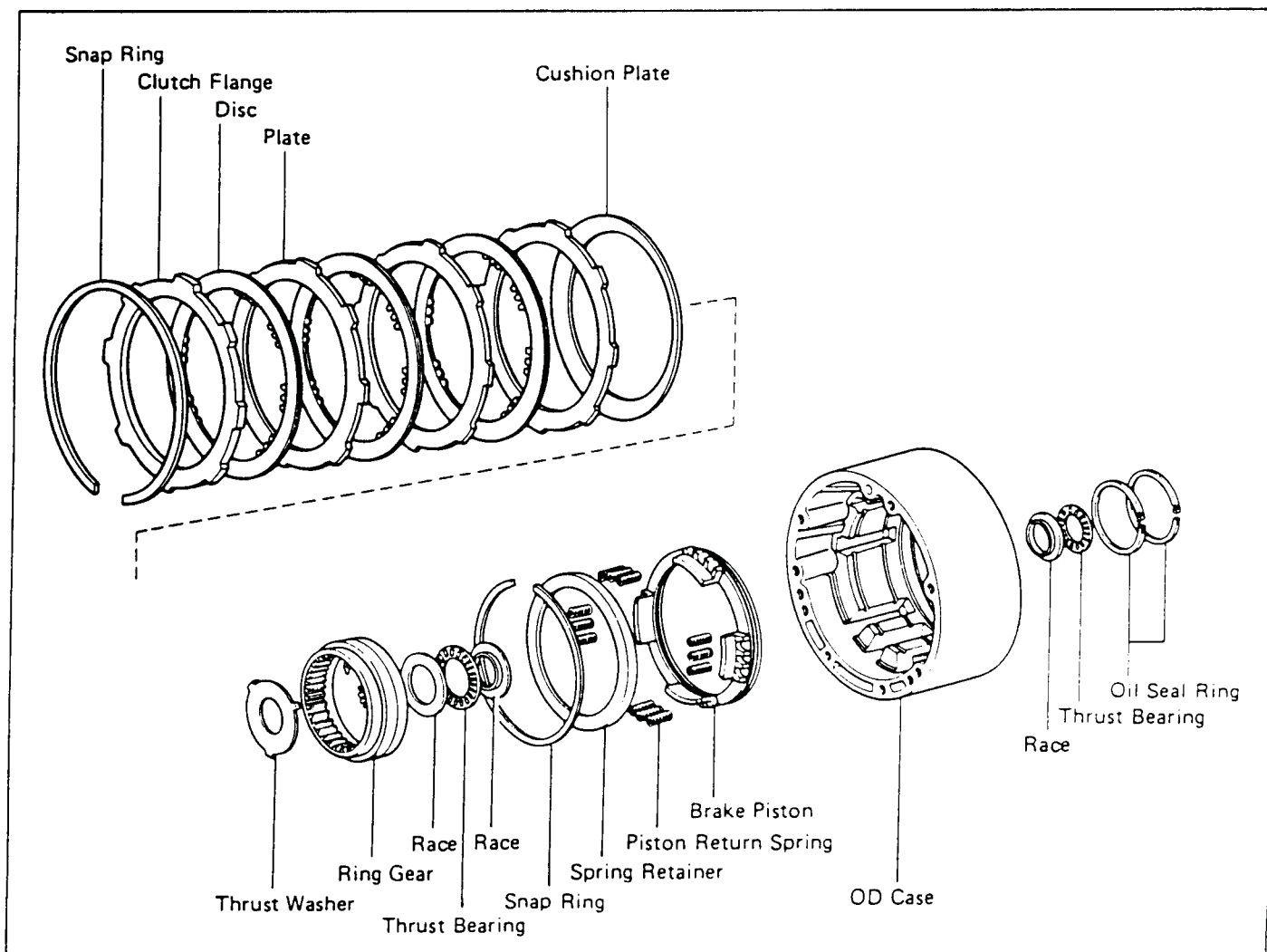

### DISASSEMBLY OF OVERDRIVE CASE AND BRAKE

REMOVE RACE FROM OVERDRIVE

REMOVE OUTER SNAP RING FROM OVERDRIVE CASE

REMOVE CLUTCH FLANGE, DISCS PLATES AND CUSHION PLATE

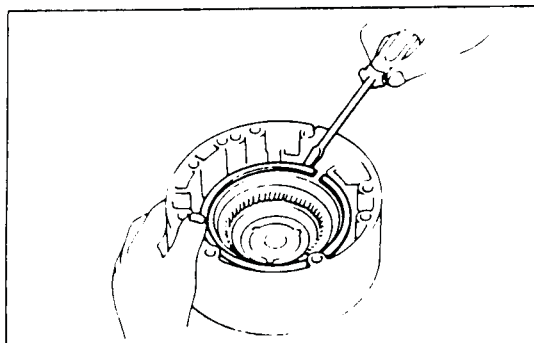



## Technical Service Information

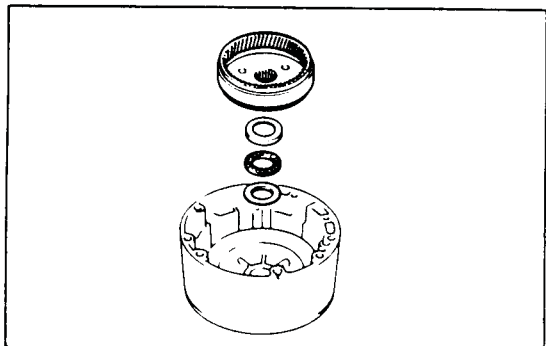

### REMOVE RING GEAR AND THRUST WASHER

### REMOVE THRUST BEARING AND RACES FROM OVERDRIVE CASE

Note the position of the races.

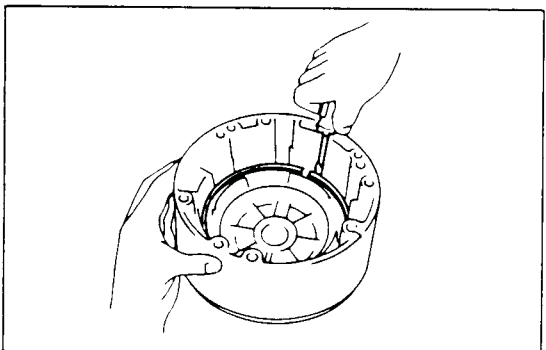

### REMOVE SNAP RING, SPRING RETAINER AND RETURN SPRINGS

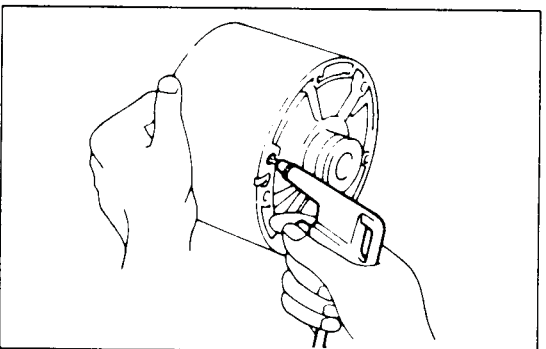

### REMOVE BRAKE PISTON

Blow compressed air through the case hole indicated in the figure to pop out the brake piston.

If the piston does not pop out, lift it out with needle-nose pliers.

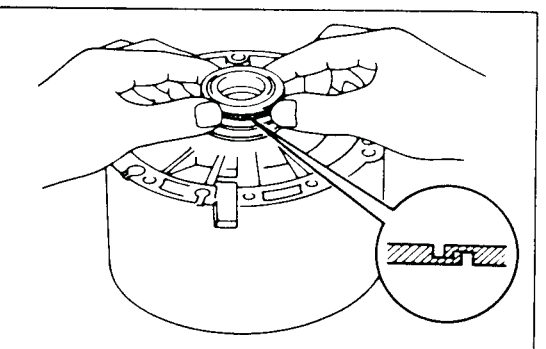

### REMOVE TWO OIL SEAL RINGS FROM OVERDRIVE CASE

### REMOVE O-RINGS FROM PISTON

### INSPECTION OF OVERDRIVE CASE AND BRAKE

NOTE: Do not allow the discs to dry out.

Prepare new discs by soaking them at least two hours in ATF.

### ASSEMBLY OF OVERDRIVE CASE AND BRAKE

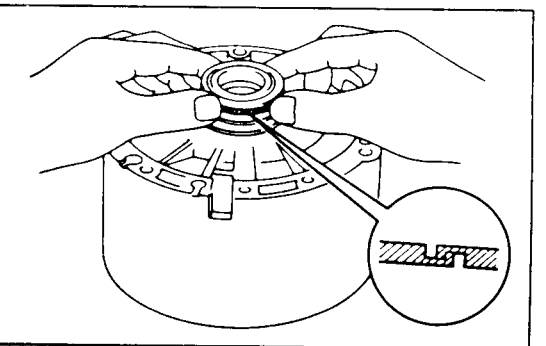

### INSTALL TWO OIL SEAL RINGS ON OVERDRIVE CASE

Spread the rings apart and slide them into the groove. Hook both ends by hand.

### INSTALL NEW O-RING ON PISTON



## Technical Service Information

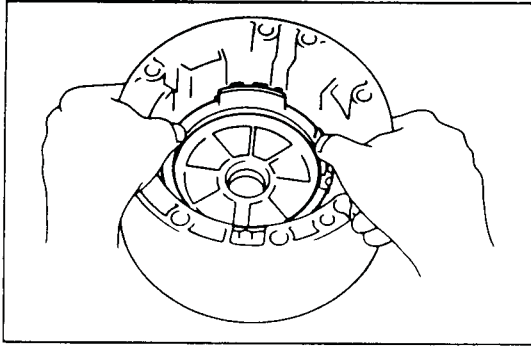

### INSTALL BRAKE PISTON IN OVERDRIVE CASE

Install the piston with cup side up, being careful not to damage the O-rings.

### INSTALL TWELVE RETURN SPRINGS AND SET RETAINER AND SNAP RING IN PLACE

Check that the ends of snap ring are not aligned with one of the cutouts.

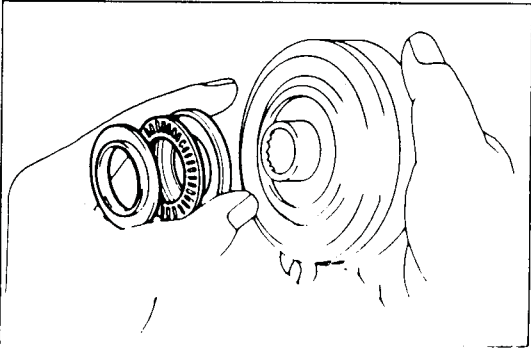

### INSTALL THRUST BEARING AND RACES TO RING GEAR AND SET RING GEAR IN OVERDRIVE CASE

NOTE: Make sure that the races are installed in correct direction.

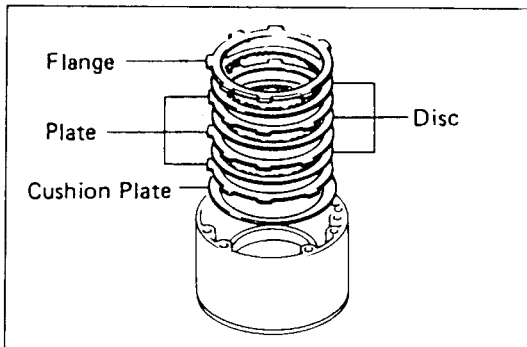

### INSTALL CUSHION PLATE, DISCS, PLATES AND FLANGE

Using low-pressure compressed air, blow all excess ATF from the discs.

**CAUTION:** High-pressure air will damage the discs.

Install in order: Cushion plate (rounded end down)-plate-disc-plate-disc-plate-disc-flange (flat side down)

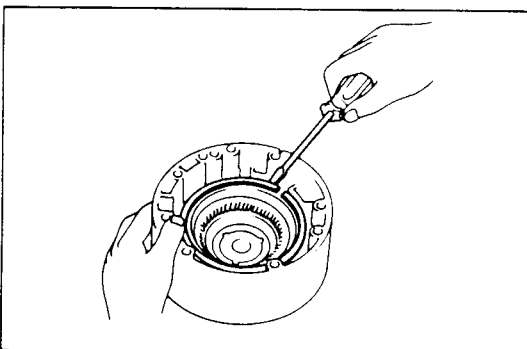

### INSTALL SNAP RING

Check that the ends of the snap ring are not aligned with one of the cutouts.

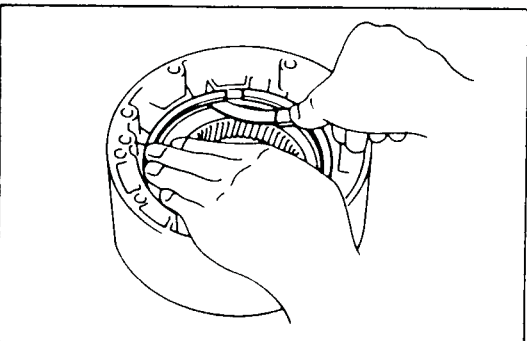

### MEASURE BRAKE CLEARANCE

Measure the distance between the snap ring and flange.

Standard clearance: 0.40 – 1.38 mm  
(0.0157 – 0.0543 in.)

### KEEP THRUST WASHER FOR ASSEMBLY

The thrust washer left over will be installed later, as the transmission is assembled.



## Front Clutch

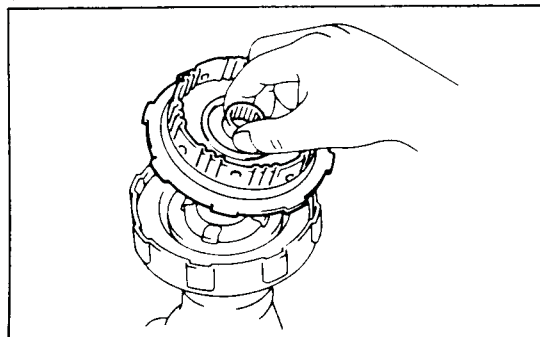
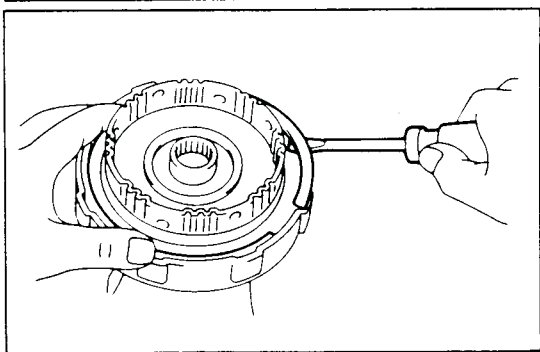
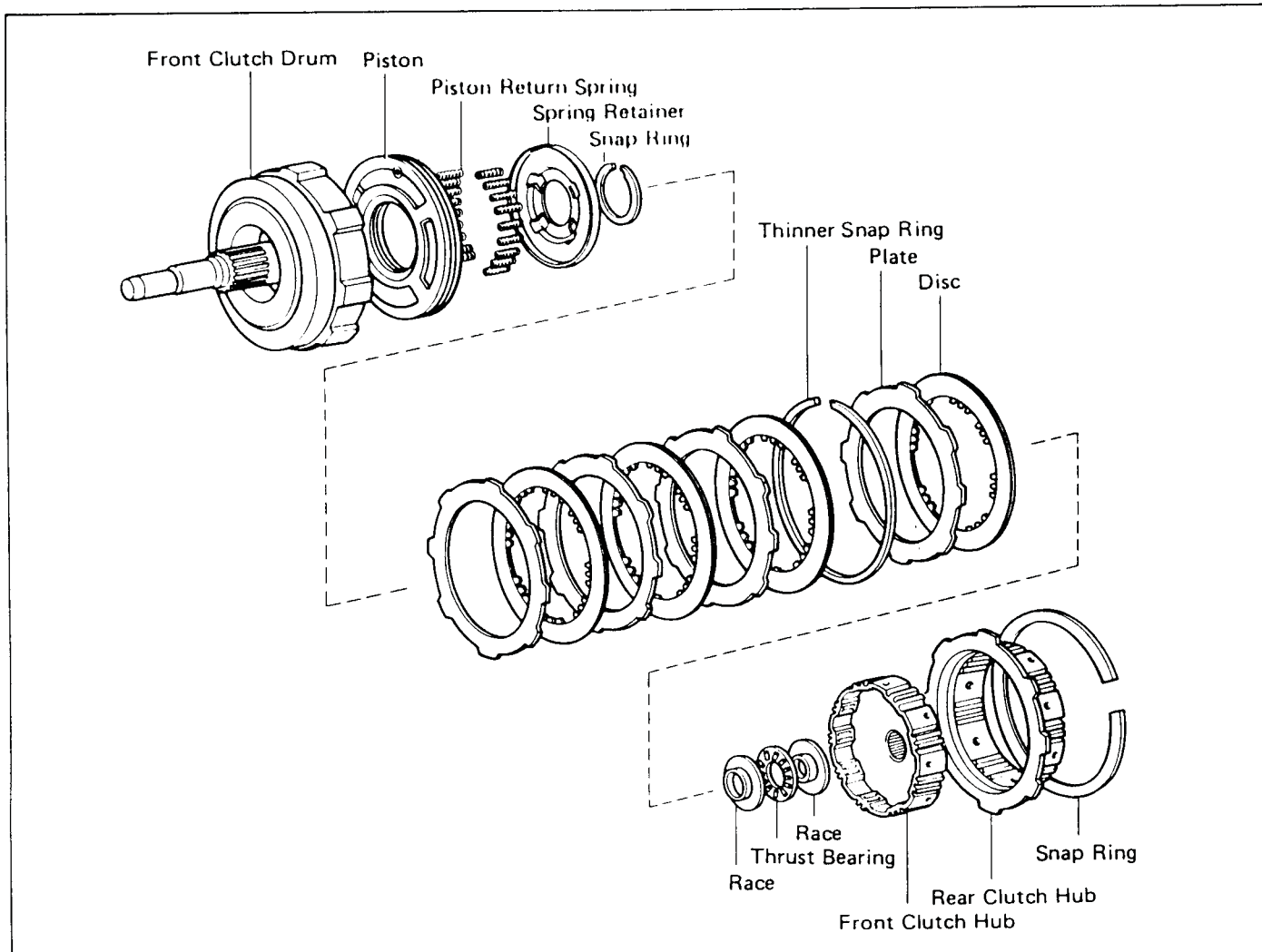

### DISASSEMBLY OF FRONT CLUTCH

**REMOVE THRUST BEARINGS AND RACES FROM BOTH SIDES OF CLUTCH**

Note the position of the races.

**USE EXTENSION HOUSING AS WORK STAND**

**REMOVE SNAP RING FROM FRONT CLUTCH DRUM**

**REMOVE FRONT AND REAR CLUTCH HUB**

Lift out the two clutch hubs together.



## Technical Service Information

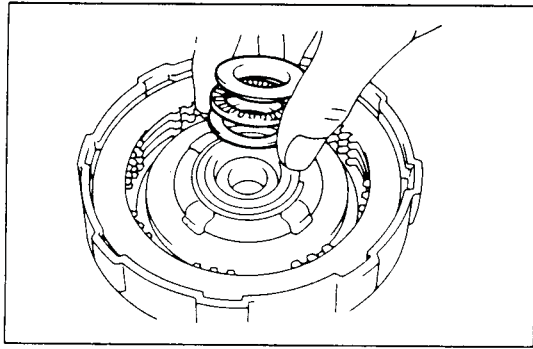

### REMOVE THRUST BEARING AND RACES

Note the position of the races.

### REMOVE DISC

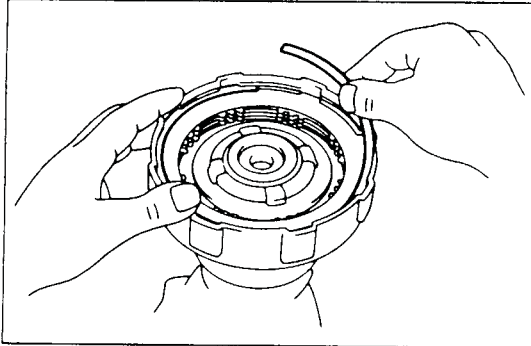

### REMOVE THINNER SNAP RING

### REMOVE REMAINING CLUTCH PLATES AND DISCS

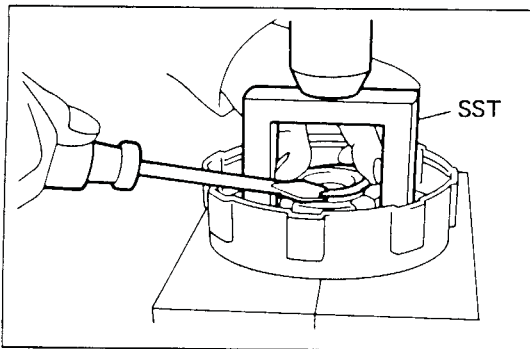

### COMPRESS PISTON RETURN SPRINGS AND REMOVE SNAP RING

Place SST on the spring retainer and compress the springs with a shop press.

Remove the snap ring with a screwdriver.

SST 09350-20013

### REMOVE SPRING RETAINER AND EIGHTEEN SPRINGS

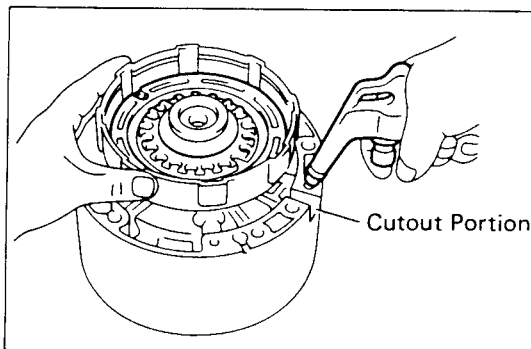

### ASSEMBLE FRONT CLUTCH ON OVERDRIVE CASE AND BLOW OUT PISTON

- Slide the front clutch onto the overdrive case.
- Apply compressed air to the overdrive case to remove the piston. (If the piston does not come out, use pliers to remove it.)
- Remove the front clutch from the overdrive case.

### REMOVE O-RINGS FROM PISTON

## INSPECTION OF FRONT CLUTCH

### INSPECT FRONT CLUTCH PISTON

- Check that the check ball is free by shaking the piston.
- Check that valve does not leak by applying low-pressure compressed air.

NOTE: Do not allow the discs to dry out. Prepare new discs by soaking them at least two hours in ATF.





## Technical Service Information

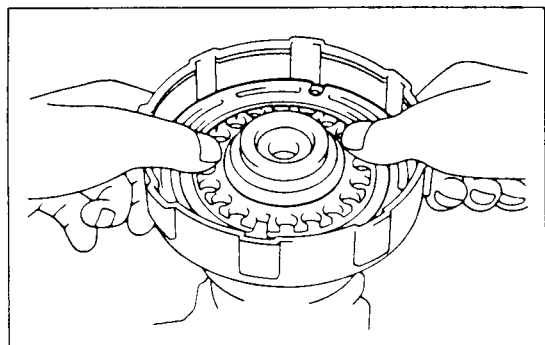

### ASSEMBLY OF FRONT CLUTCH

(See page AT-64)

#### INSTALL NEW O-RINGS ON PISTON

#### INSTALL PISTON IN FRONT OF CLUTCH DRUM

Press the piston into the housing with the cup side up (check ball down).

Be careful not to damage the O-rings.

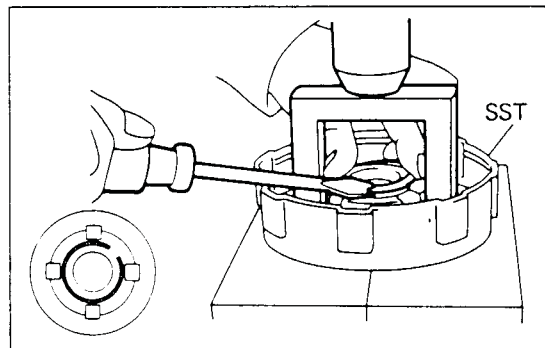

#### INSTALL EIGHTEEN PISTON RETURN SPRINGS, SPRING RETAINER AND SNAP RING IN PLACE

#### COMPRESS RETURN SPRINGS AND INSTALL SNAP RING IN GROOVE

(a) Place SST on the spring retainer, and compress the springs with a shop press.

SST 09350-20013

(b) Install the snap ring with a screwdriver.

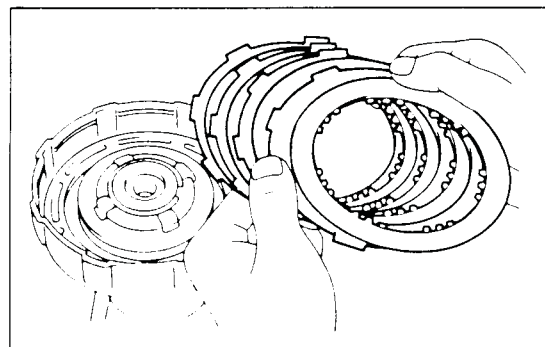

#### INSTALL DISCS AND PLATES WITHOUT ASSEMBLING THINNER SNAP RING

(a) Do not assemble the thinner snap ring yet.

(b) Using low-pressure compressed air, blow all excess ATF from the discs. For measurement of the clutch pack, install all plates and discs (temporarily without thinner snap ring).

**CAUTION:** High-pressure air will damage the discs.

Install in order: Plate-disc-plate-disc-plate-disc-plate (no snap ring)-disc

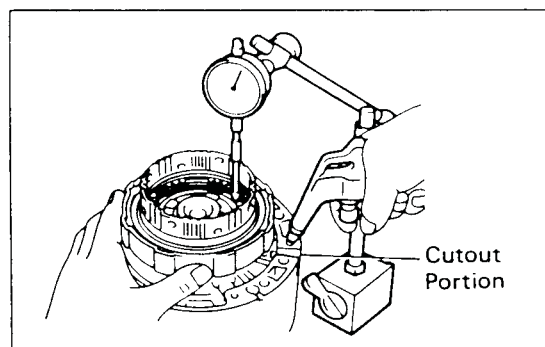

#### CHECK PISTON STROKE OF FRONT CLUTCH

(a) Install the rear clutch hub and the outer snap ring.

(b) Install the front clutch drum onto the overdrive case.

With a dial indicator, measure the stroke applying and releasing the compressed air (4 – 8 kg/cm<sup>2</sup>, 57 – 114 psi or 392 – 785 kPa) as shown.

**Standard piston stroke: 1.40 – 2.24 mm  
(0.0551 – 0.0882 in.)**

If not within specification, select a proper plate.

NOTE: There are two different thickness.

**Plate thickness: 1.8 mm (0.071 in.)  
2.0 mm (0.079 in.)**



## Technical Service Information

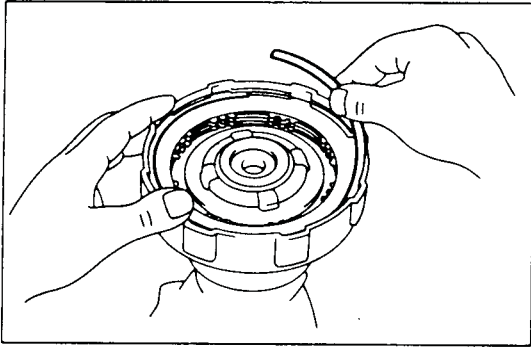

### INSTALL THINNER SNAP RING IN CLUTCH DRUM

- Remove the outer snap ring, rear clutch hub and disc to allow installation of the thinner snap ring.
- Compress and lower the snap ring into the groove by hand. Check that the ends of the snap ring are not aligned with one of the cutouts.

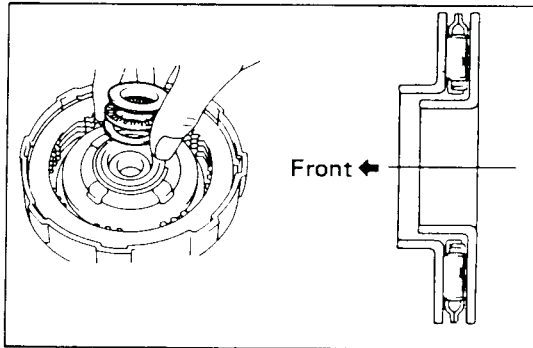

### INSTALL DISC

#### INSTALL INNER THRUST BEARING AND RACES

**IMPORTANT:** Coat parts with petroleum jelly to hold them in place.

Install the inner race, needle bearing and outer race. Press them into place.

**NOTE:** Face the lip of race toward the front of the clutch body.

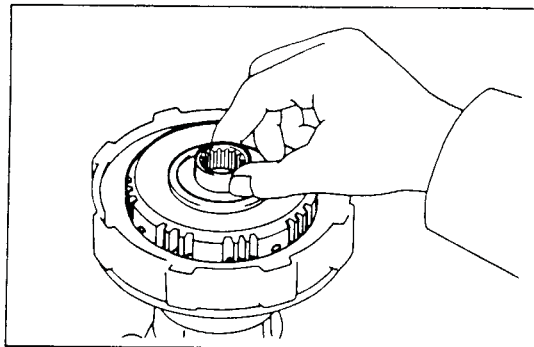

### INSTALL FRONT CLUTCH HUB

Align the disc lugs with the hub teeth. Make sure the hub meshes with all discs and is fully inserted.

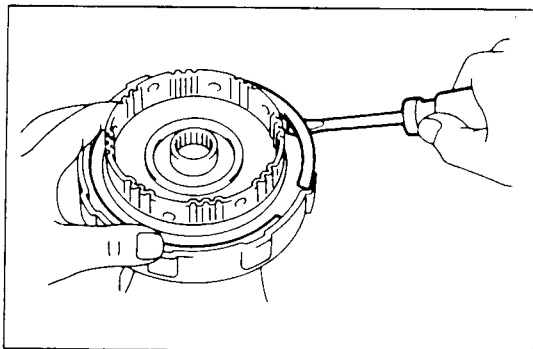

### INSTALL REAR CLUTCH HUB AND OUTER SNAP RING

Check that the snap ring ends are not aligned with one of the cutouts.

**NOTE:** Note the position of the inner thrust bearing and races, and keep them together until assembly.

### KEEP THRUST BEARINGS AND RACES TOGETHER



## Rear Clutch

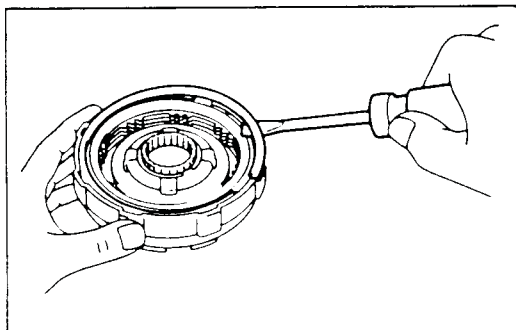
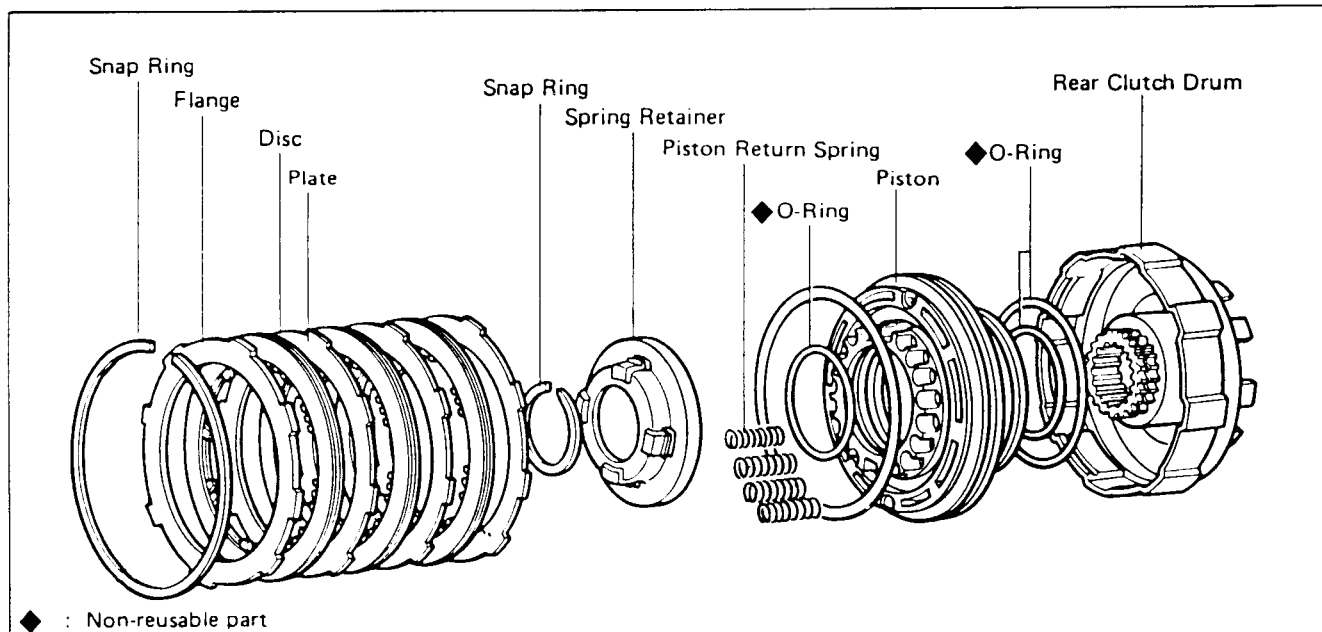

### DISASSEMBLY OF REAR CLUTCH

**REMOVE OUTER CLUTCH PACK RETAINING SNAP RING FROM DRUM**

**REMOVE CLUTCH FLANGE, DISCS AND PLATES**

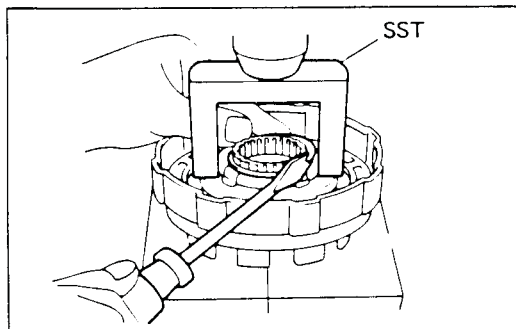

**COMPRESS PISTON RETURN SPRINGS AND REMOVE SNAP RING**

Place SST on the spring retainer and compress the springs with a shop press.

Using a screwdriver, remove the snap ring.

SST 09350-20013

**REMOVE SPRING RETAINER, SNAP RING AND EIGHTEEN RETURN SPRINGS**

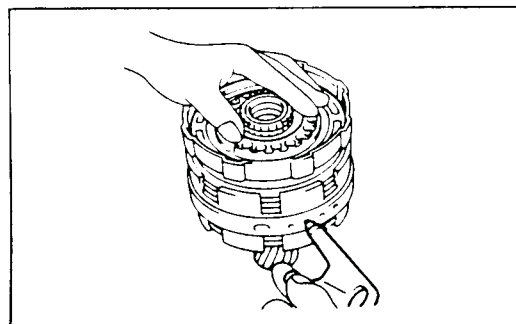

**ASSEMBLE REAR CLUTCH ON CENTER SUPPORT AND BLOW OUT PISTON**

- Slide rear clutch onto the center support.
- Apply compressed air to center support to remove the piston. (If the piston does not come out, use pliers to remove it.)
- Remove the front clutch from the center support.

**REMOVE O-RINGS FROM REAR CLUTCH PISTON**

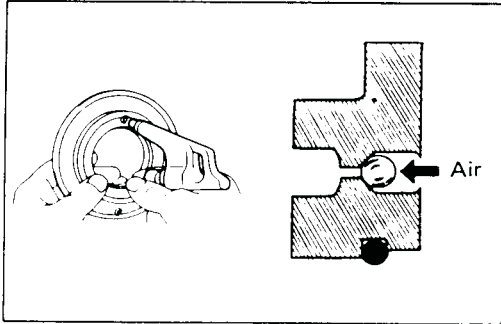

## INSPECTION OF REAR CLUTCH

### INSPECT REAR CLUTCH PISTON

- (a) Check that check ball is free by shaking each piston.
- (b) Check that the valve is not leaking by applying low-pressure compressed air.

NOTE: Do not allow the discs to dry out. Prepare new discs by soaking them at least two hours in ATF.

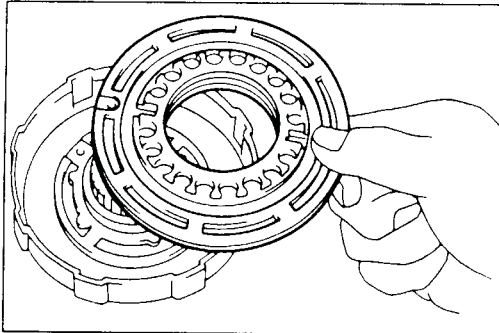

## ASSEMBLY OF REAR CLUTCH

(See page AT-68)

### 1. INSTALL NEW O-RINGS ON PISTON

### 2. INSTALL REAR CLUTCH PISTON IN DRUM

Press rear clutch piston into drum with the cup side up, being careful not to damage the O-rings.

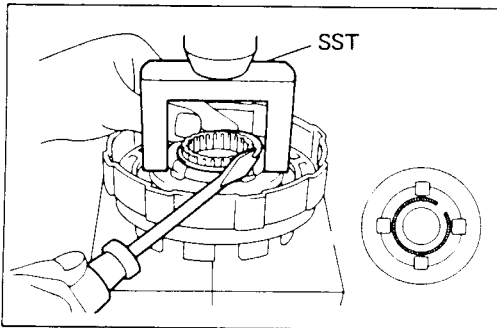

### 3. INSTALL EIGHTEEN PISTON RETURN SPRINGS AND SET RETAINER WITH SNAP RING IN PLACE

### 4. COMPRESS RETURN SPRINGS AND INSTALL SNAP RING IN GROOVE

- (a) Place SST on the spring retainer, and compress the springs on shop press.

SST 09350-20013

- (b) Install the snap ring with snap ring pliers.

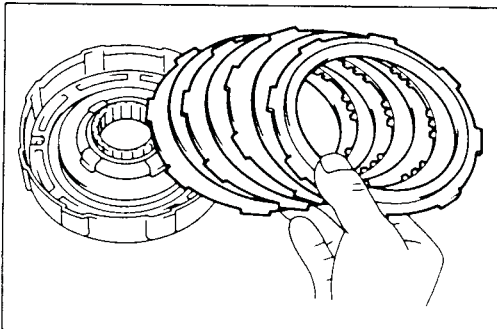

### 5. INSTALL DISCS, PLATES AND FLANGE

Using low-pressure compressed air, blow all excess ATF from discs.

**CAUTION:** High-pressure air will damage the discs.

Install in order: Plate-disc-plate-disc-plate-disc-flange (flat end down)

### 6. INSTALL SNAP RING

Check that the snap ring ends are not aligned with one of the cutouts.

### 7. CHECK PISTON STROKE OF REAR CLUTCH

Install the rear clutch onto the center support. With a dial indicator, measure the stroke applying and releasing the compressed air (4 – 8 kg/cm<sup>2</sup>, 57 – 114 psi or 392 – 785 kPa) as shown.

Standard piston stroke: 0.90 – 1.75 mm  
(0.0354 – 0.0689 in.)

If not within specification, select a proper flange. There are three different thickness.

Flange thickness: 3.6 mm, 3.8 mm, 4.0 mm  
(0.142 in., 0.150 in., 0.157 in.)

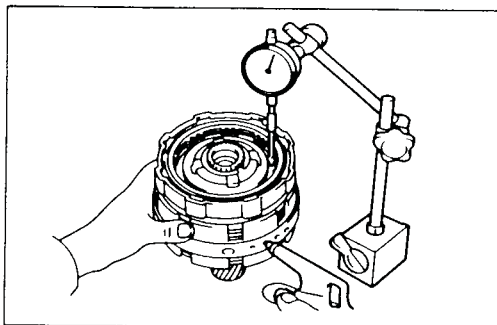



## Center Support Assembly

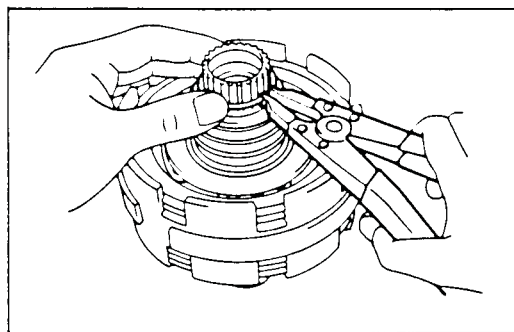
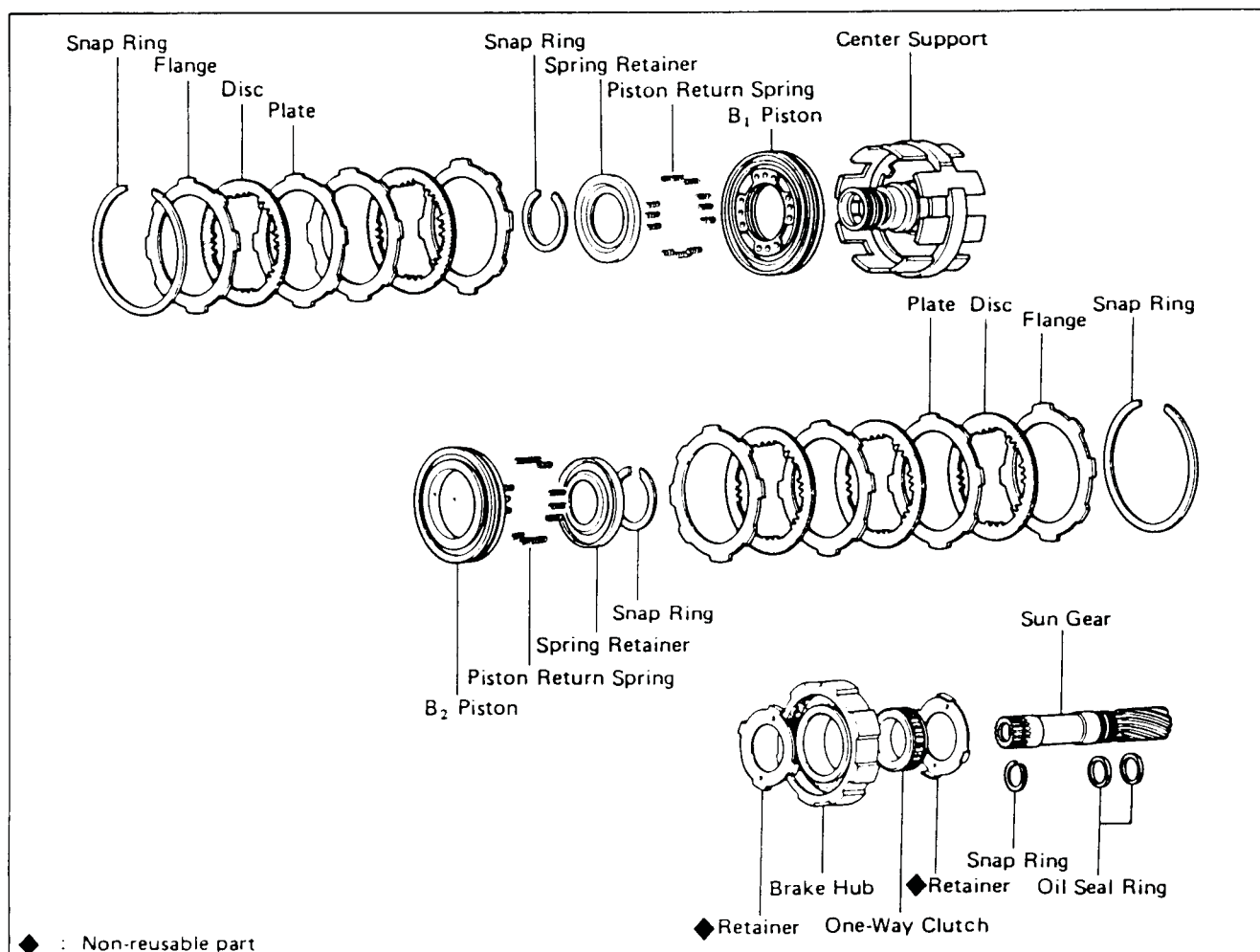

### DISASSEMBLY OF CENTER SUPPORT ASSEMBLY

- REMOVE SNAP RING FROM END OF SUN GEAR SHAFT
- PULL CENTER SUPPORT ASSEMBLY FROM SHAFT

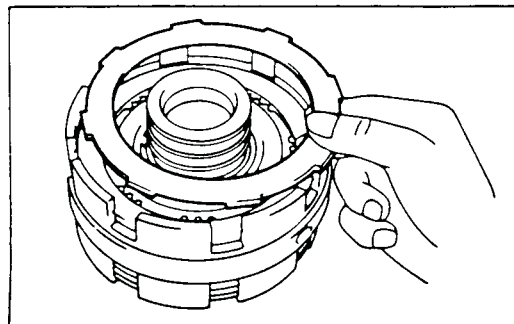

- REMOVE SNAP RING FROM FRONT OF CENTER SUPPORT ASSEMBLY (NO. 1 BRAKE)
- REMOVE CLUTCH FLANGE, DISCS AND PLATES (NO. 1 BRAKE)



## Technical Service Information

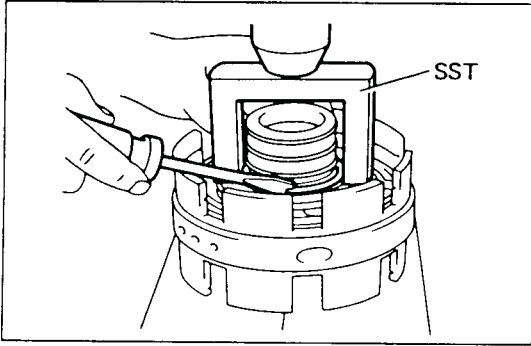

### COMPRESS PISTON RETURN SPRINGS AND REMOVE SNAP RING

Place SST on spring retainer and compress the springs with a shop press.

Using a screwdriver, remove the snap ring.

SST 09350-20013

### REMOVE SPRING RETAINER AND TWELVE SPRINGS

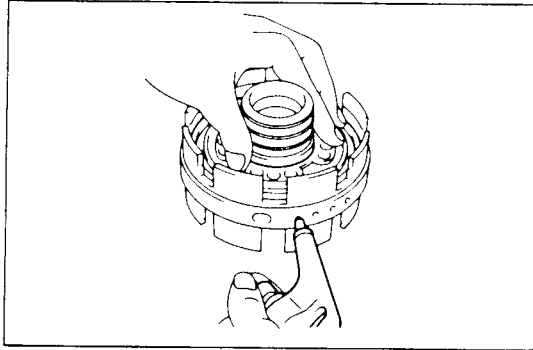

### REMOVE NO. 1 BRAKE PISTON

Blow compressed air through the center support oil hole to remove the No. 1 brake piston.

If the piston does not pop out, lift it out with needle-nose pliers.

### REMOVE NO. 1 BRAKE PISTON O-RINGS

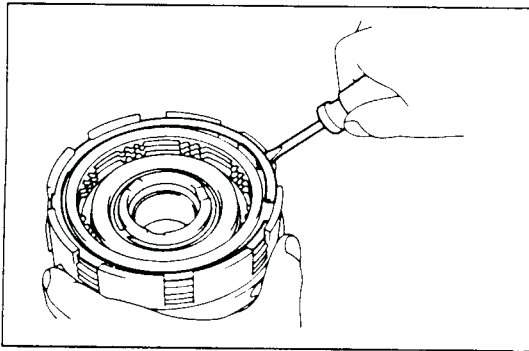

### TURN CENTER SUPPORT ASSEMBLY OVER AND REMOVE REAR SNAP RING (NO. 2 BRAKE)

### REMOVE CLUTCH FLANGE, DISCS AND PLATES (NO. 2 BRAKE)

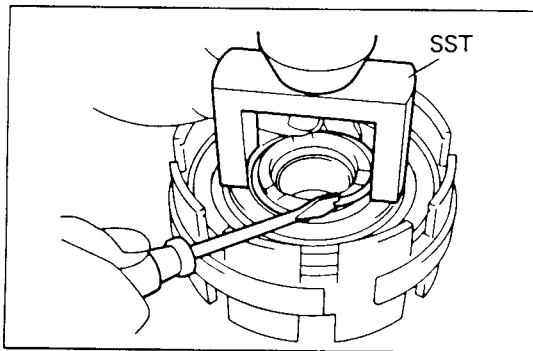

### COMPRESS PISTON RETURN SPRINGS AND REMOVE SNAP RING

Place SST on spring retainer and compress the springs with a shop press.

Using a screwdriver, remove the snap ring.

SST 09350-20013

### REMOVE SPRING RETAINER AND TWENTY SPRINGS

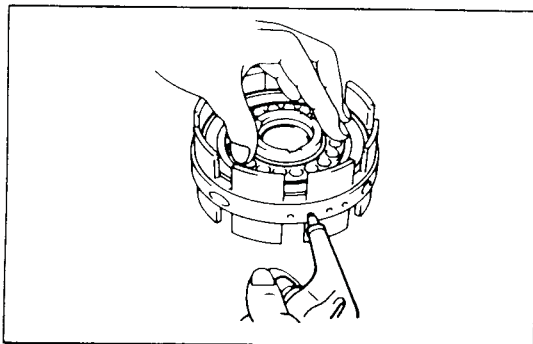

### REMOVE NO. 2 BRAKE PISTON

Blow compressed air through the center support oil hole to remove the No. 2 brake piston.

If the piston does not pop out, lift it out with needle-nose pliers.

### REMOVE NO. 2 BRAKE PISTON O-RINGS



## Technical Service Information

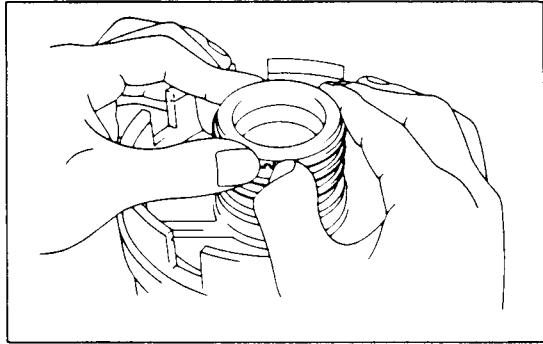

**REMOVE THREE OIL SEAL RINGS FROM CENTER SUPPORT**

**CAUTION:** Do not spread the ring ends too much.

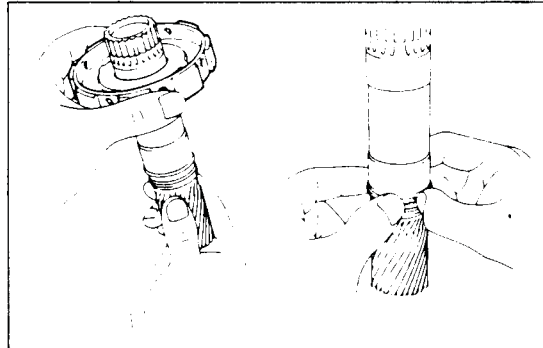

**REMOVE ONE-WAY CLUTCH ASSEMBLY AND OIL SEAL RINGS FROM SUN GEAR**

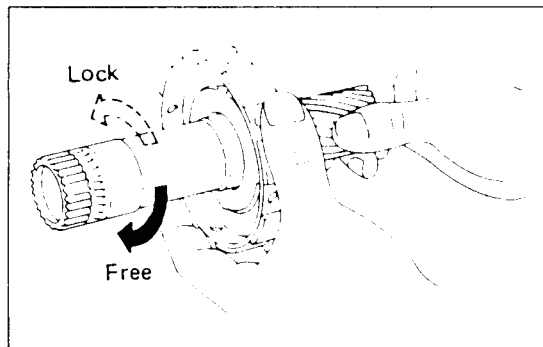

### INSPECTION OF CENTER SUPPORT ASSEMBLY

#### CHECK OPERATION OF ONE-WAY CLUTCH

Hold the No. 2 brake hub and turn the sun gear. The sun gear should turn freely counterclockwise and should lock clockwise.

If the one-way clutch does not work properly, replace it.

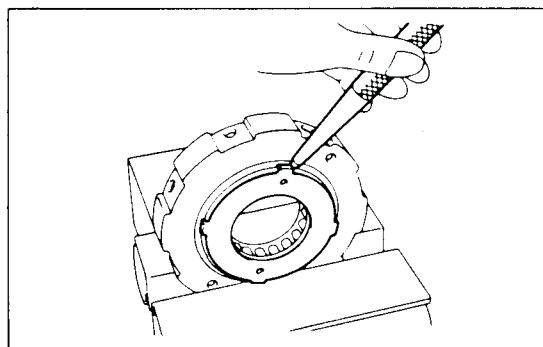

#### IF NECESSARY, REPLACE ONE-WAY CLUTCH

- Bend several tabs back with a tapered punch.
- Pry off the retainer with a screwdriver. Leave the other retainer on the hub.
- Remove the one-way clutch.

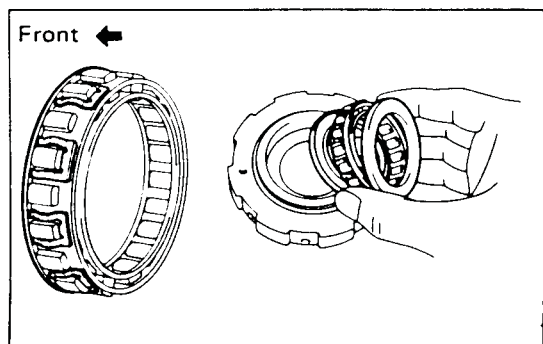

- Install the one-way clutch into the brake hub, facing the spring cage toward the front.



## Technical Service Information

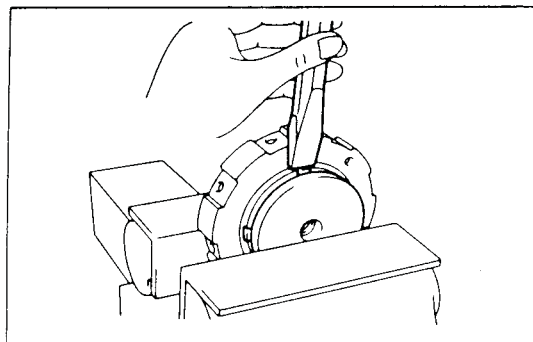

(e) Hold the brake hub in a vise with soft jaws, and flatten the ears with a chisel.

(f) Check to make sure that the retainer is centered.

NOTE: Do not allow the discs to dry out.

Prepare new discs by soaking them at least two hours in ATF.

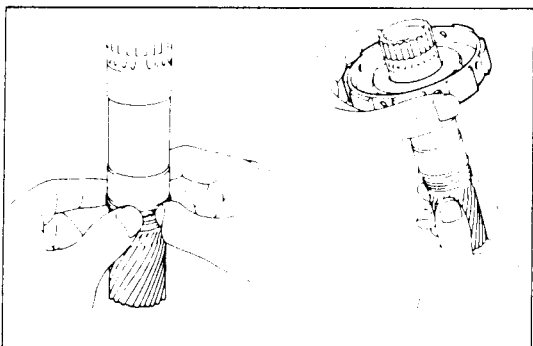

### ASSEMBLY OF CENTER SUPPORT ASSEMBLY

(See page AT-70)

**INSTALL TWO OIL SEAL RINGS AND ONE-WAY CLUTCH ASSEMBLY ON SUN GEAR**

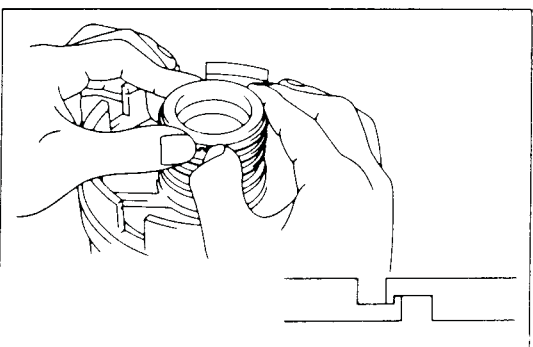

**INSTALL THREE OIL SEAL RINGS ON CENTER SUPPORT**

Spread the rings apart and slip them into the groove. Hook both ends by hand.

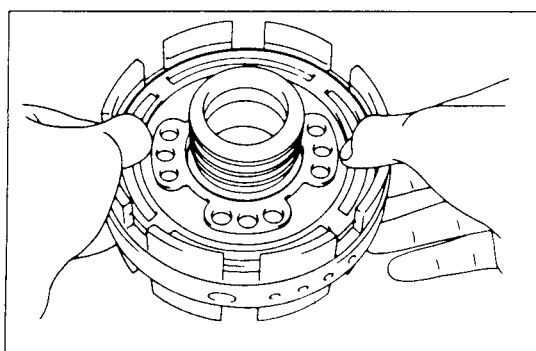

**INSTALL NEW O-RINGS ON PISTON**

**INSTALL NO. 1 BRAKE PISTON IN CENTER SUPPORT**

Press the No. 1 brake piston into the center support with the cup side up, being careful not to damage the O-rings.

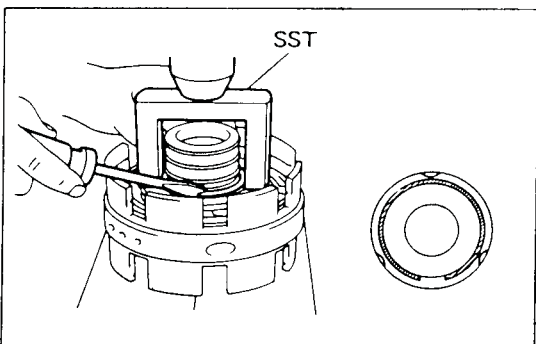

**INSTALL TWELVE PISTON RETURN SPRINGS AND SET RETAINER WITH SNAP RING IN PLACE**

**COMPRESS RETURN SPRINGS AND INSTALL SNAP RING IN GROOVE**

(a) Place SST on the spring retainer, and compress the springs on a shop press.

SST 09350-20013

(b) Install the snap ring using a screwdriver.





## Technical Service Information

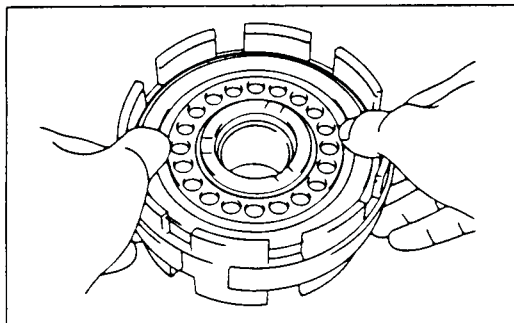

### INSTALL NEW O-RINGS ON PISTON AND CENTER SUPPORT

### TURN CENTER SUPPORT OVER AND INSTALL NO. 2 BRAKE PISTON

Press the No. 2 brake piston into the center support with the cup side up, being careful not to damage the O-rings.

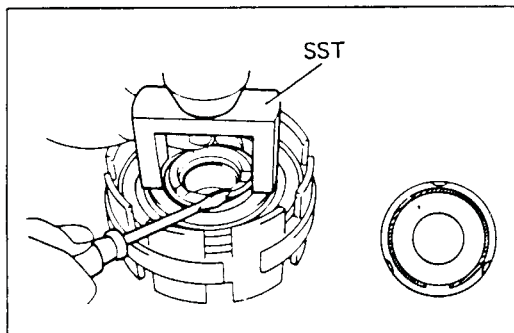

### INSTALL TWENTY PISTON RETURN SPRINGS AND SET RETAINER WITH SNAP RING IN PLACE

### COMPRESS RETURN SPRINGS AND INSTALL SNAP RING IN GROOVE

(a) Place SST on the spring retainer, and compress the springs on a shop press.

SST 09350-20013

(b) Install the snap ring with a screwdriver.

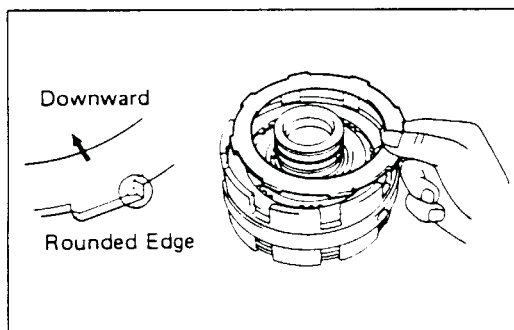

### TURN CENTER SUPPORT OVER AND INSTALL NO. 1 BRAKE PISTON PLATE, DISC AND FLANGE

Using the low-pressure compressed air, blow all excess ATF from the disc.

**CAUTION:** High-pressure air will damage the disc.

Install in order: Plate-disc-plate-plate-disc-flange (rounded edge down)

### INSTALL SNAP RING IN CENTER SUPPORT

Check that snap ring ends are not aligned with one of the cutouts.

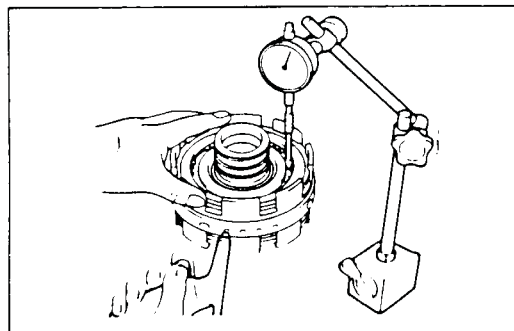

### CHECK PISTON STROKE OF NO. 1 BRAKE

With a dial indicator, measure the stroke applying and releasing the compressed air (4 – 8 kg/cm<sup>2</sup>, 57 – 114 psi or 392 – 785 kPa) as shown.

Standard piston stroke: 0.80 – 1.73 mm  
(0.0315 – 0.0681 in.)

If the stroke exceeds the limit, the clutch pack is probably worn. If the stroke is less than the limit, parts may be mis-assembled or there may be excess ATF on the discs.

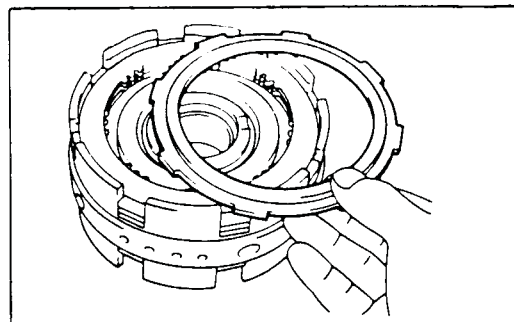

### TURN CENTER SUPPORT OVER AND INSTALL NO. 2 BRAKE PLATES, DISCS AND FLANGE

Using the low-pressure compressed air, blow all excess ATF from the discs.

**CAUTION:** High-pressure air will damage the disc.

Install in order: Plate-disc-plate-disc-plate-disc-flange (flat side down)

### INSTALL SNAP RING IN CENTER SUPPORT

Check that the snap ring ends are not aligned with one of the cutouts.

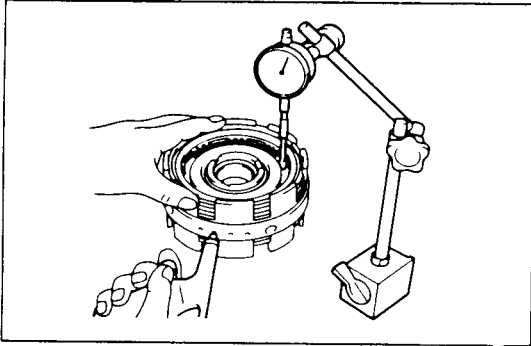

## CHECK PISTON STROKE OF NO. 2 BRAKE

With a dial indicator, measure the stroke applying and releasing the compressed air (4 – 8 kg/cm<sup>2</sup>, 57 – 114 psi or 392 – 785 kPa) as shown.

**Standard piston stroke: 1.01 – 2.25 mm  
(0.0398 – 0.0886 in.)**

If the stroke exceeds the limit, the clutch pack is probably worn. If the stroke is less than the limit, parts may be mis-assembled or there may be excess ATF on the discs.

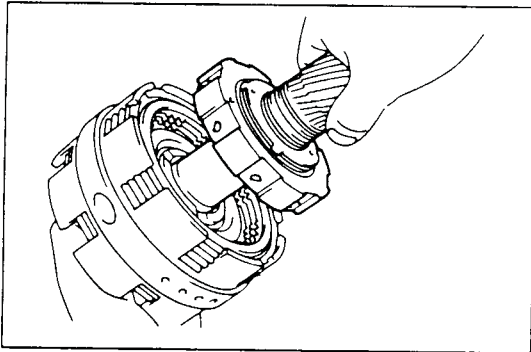

## ASSEMBLE CENTER SUPPORT AND SUN GEAR SHAFT

- (a) Align the brake No. 2 disc flukes.
- (b) Mesh the brake hub with the discs, twisting and jiggling the hub as required.

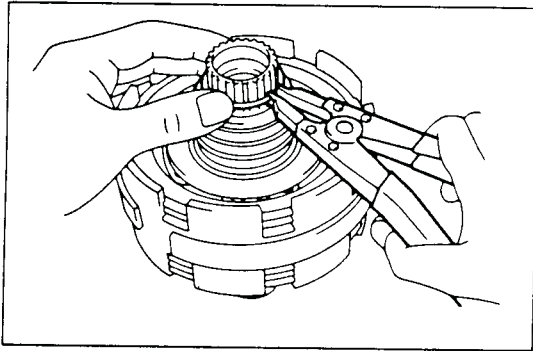

## INSTALL SNAP RING ON END OF SUN GEAR SHAFT



## Planetary Gear Output Shaft

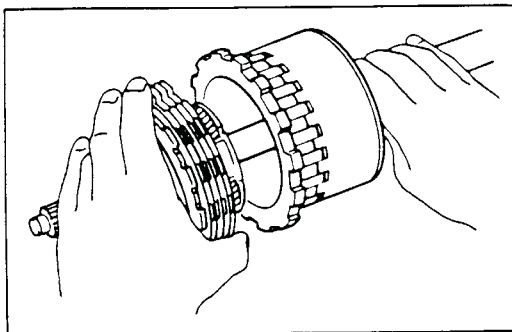
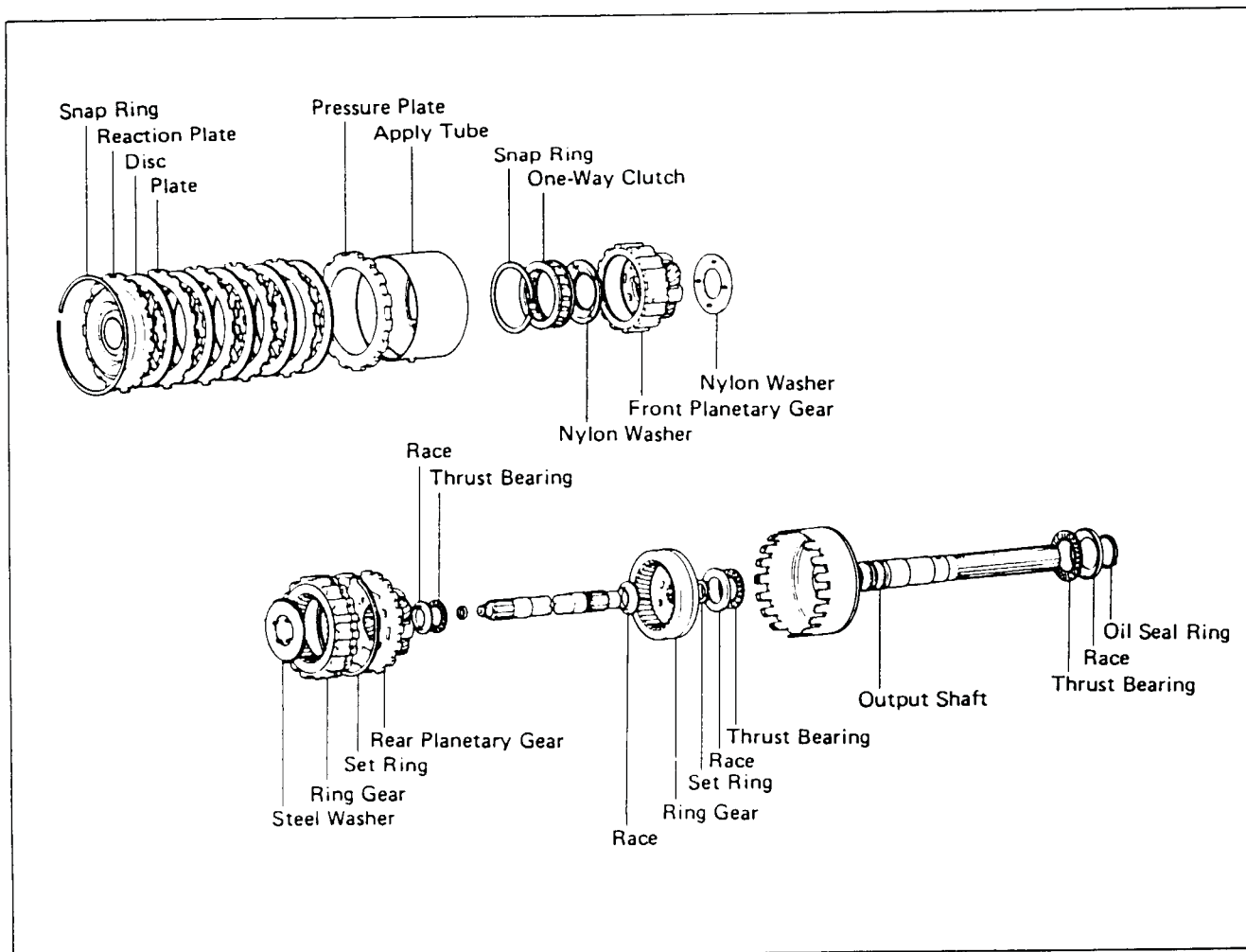

### DISASSEMBLY OF PLANETARY GEAR OUTPUT SHAFT

#### REMOVE NO. 3 BRAKE DISC/PLATE PACK AND FRONT PLANETARY PINION GEARS

Grasp the components and pull off the front end of the output shaft.  
Be careful to avoid dropping the bearing on the output shaft.

#### REMOVE THRUST WASHER FROM PLANETARY GEARS

NOTE: The thrust washer may have stuck to the inside of the planetary gear case.

#### REMOVE BRAKE DISCS AND PLATES FROM PLANETARY GEARS

#### REMOVE REACTION PLATE FROM PLANETARY GEARS

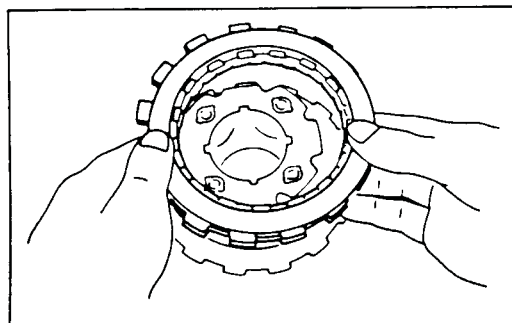

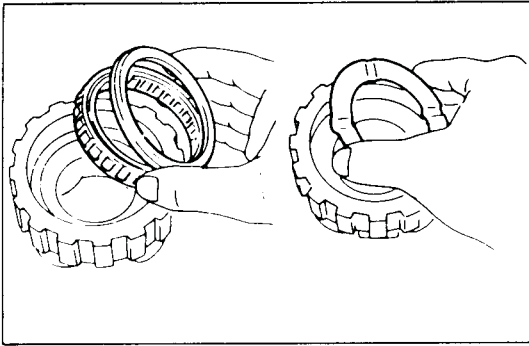

**REMOVE SNAP RING AND ONE-WAY CLUTCH FROM PLANETARY GEARS**

**REMOVE NYLON THRUST WASHER FROM PLANETARY GEARS**

**REMOVE APPLY TUBE AND CLUTCH PRESSURE PLATE**

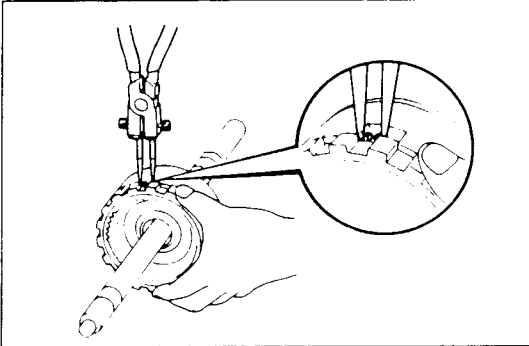

**COMPRESS SHAFT SNAP RING AND REMOVE FRONT PLANETARY RING GEAR**

While pulling up the ring gear, compress the snap ring with snap ring pliers and pull out the ring gear by hand.

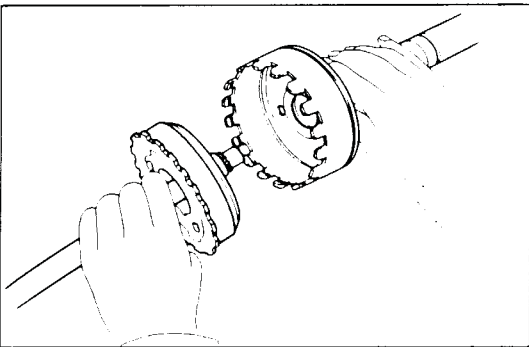

**REMOVE INTERMEDIATE SHAFT, RING GEAR AND PLANETARY GEAR FROM OUTPUT SHAFT ASSEMBLY**

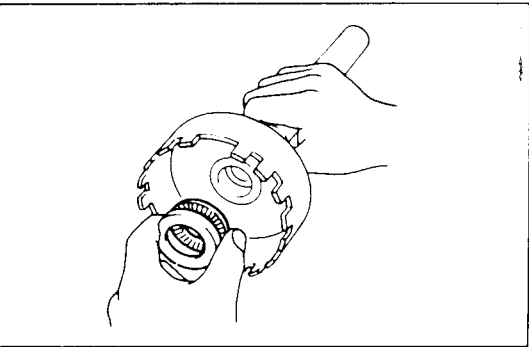

**REMOVE THRUST BEARING AND RACES FROM OUTPUT SHAFT ASSEMBLY**

Note the position of the races.

**REMOVE THREE OIL SEAL RINGS FROM OUTPUT SHAFT**

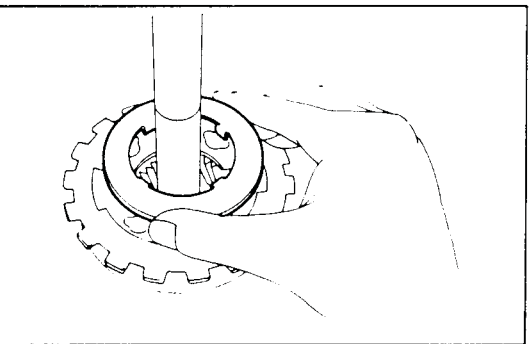

**REMOVE STEEL THRUST WASHER AND REAR PINION GEARS FROM INTERMEDIATE SHAFT ASSEMBLY**

**REMOVE RACE AND THRUST BEARING FROM INTERMEDIATE SHAFT**

Note the position of the race.



## Technical Service Information

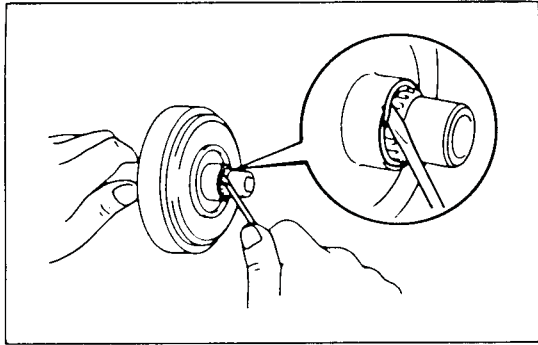

**INVERT INTERMEDIATE SHAFT AND REMOVE SET RING**

**REMOVE REAR PLANETARY RING GEAR AND BEARING RACE FROM INTERMEDIATE SHAFT**

Note the position of the race.

### INSPECTION OF PLANETARY GEAR OUTPUT SHAFT

**NOTE:** Do not allow the discs to dry out. Prepare new discs by soaking them at least two hours in ATF.

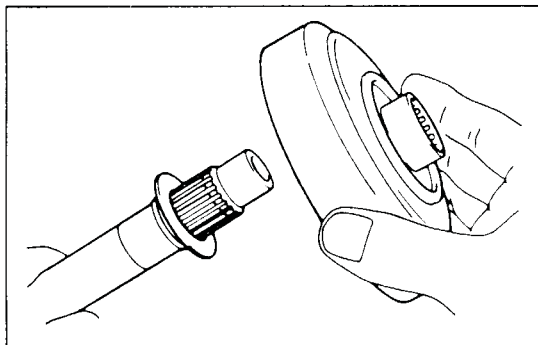

### ASSEMBLY OF PLANETARY GEAR OUTPUT SHAFT

**INSTALL THRUST BEARING RACE AND REAR PLANETARY RING GEAR ON INTERMEDIATE SHAFT**

Slip the thrust bearing race and ring gear onto the shaft with the exterior splines up, as shown.

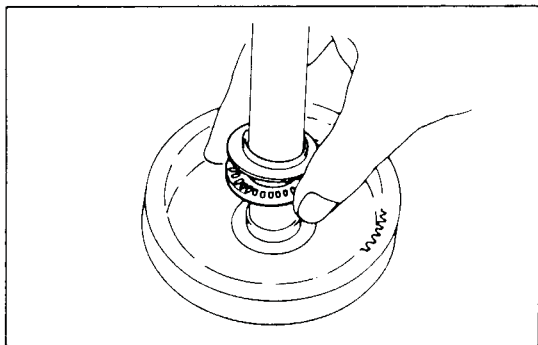

**INSTALL SET RING ON INTERMEDIATE SHAFT**

Push down and wind the set ring into place. Check to make sure it is secure.

**TURN OVER INTERMEDIATE SHAFT AND INSTALL THRUST BEARING AND RACE**

Make sure the flat side of the race is against the bearing.

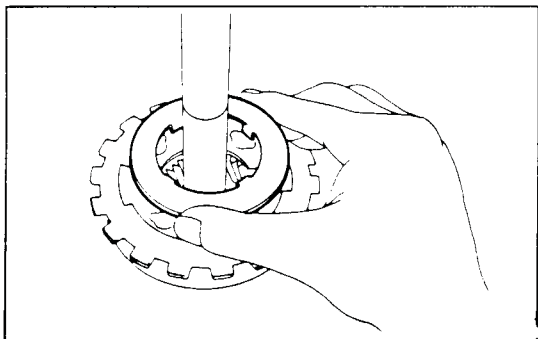

**INSTALL PINION GEAR ASSEMBLY AND STEEL THRUST WASHER ON REAR PLANETARY CARRIER**

Install the washer with the lugs down, fitting into the rear planetary gear carrier.

**CAUTION:** Make sure the different lug shapes match the openings on the plate.



## Technical Service Information

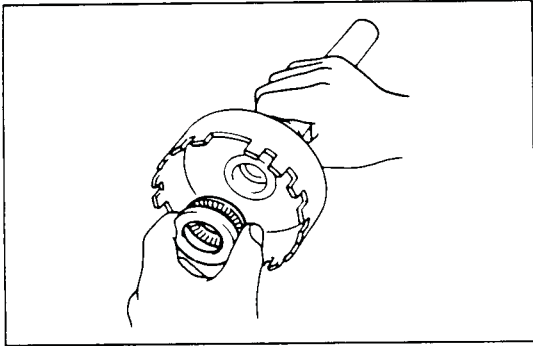

### INSTALL THREE OIL SEAL RINGS ON OUTPUT SHAFT

Spread the rings apart and slide them into the groove. Hook both ends by hand.

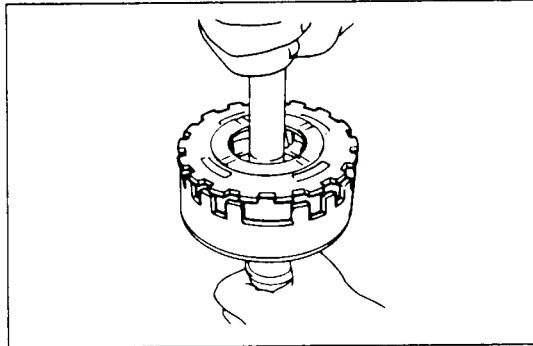

### INSTALL THRUST BEARING AND RACE ON OUTPUT SHAFT

Hold the cup of the race toward the bearing.

### USE EXTENSION HOUSING AS ASSEMBLY STAND

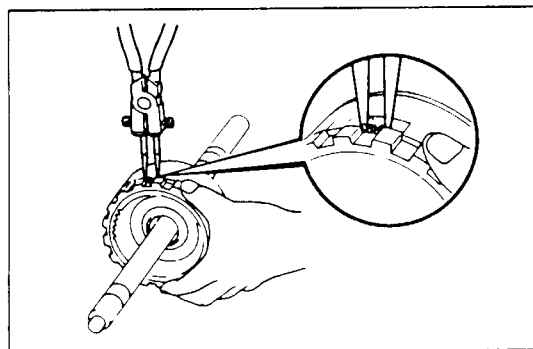

### INSTALL INTERMEDIATE SHAFT ASSEMBLY IN OUTPUT SHAFT

### INSTALL REAR PLANETARY CARRIER IN OUTPUT SHAFT

Slide the carrier into place, and make sure that the lugs interlock.

### SET IN PLACE FRONT PLANETARY RING GEAR

Slide the snap ring downward, and align the lugs with the notches. Align the ends of the snap ring with the wide gap between the teeth.

### INSTALL FRONT PLANETARY RING GEAR WITH SNAP RING

While pushing down the ring gear, squeeze the snap ring end with snap ring pliers and install it into the groove.

NOTE: When the snap ring is fully seated, the gap is the width of one lug.

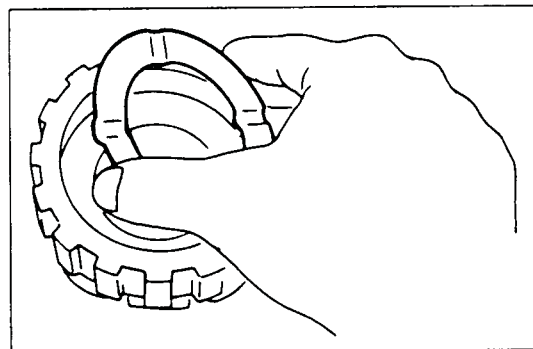

### INSTALL NYLON THRUST WASHER IN FRONT PLANETARY PINION GEAR

Face the lugs downward and match them with the slots in back of the planetary gear.

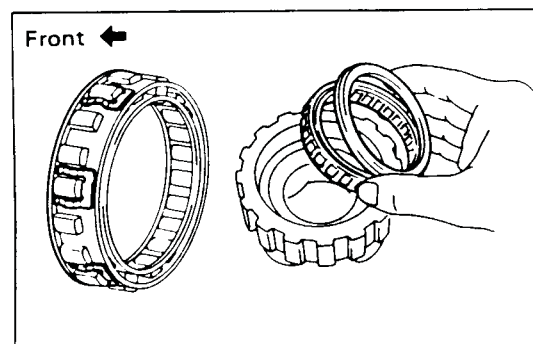

### INSTALL ONE-WAY CLUTCH

Install the one-way clutch into the outer race, facing the spring cage toward the front.



## Technical Service Information

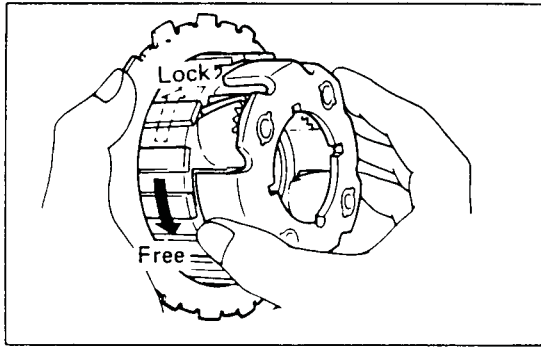

### TEMPORARILY INSTALL REACTION PLATE ON PLANETARY

Insert the plate into place for testing of the one-way clutch.

### TEST ONE-WAY CLUTCH

The planetary gear must rotate freely counterclockwise and lock clockwise.

If the clutch does not work correctly, it must be replaced.

### REMOVE REACTION PLATE

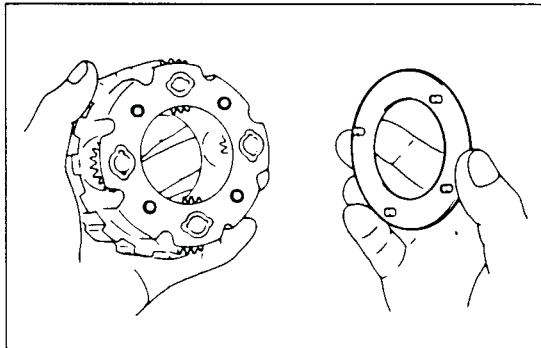

### INSTALL NYLON THRUST WASHER ON FRONT PLANETARY CARRIER

Apply petroleum jelly to the washer to hold it in place during later assembly. Match the lugs with the planetary carrier.

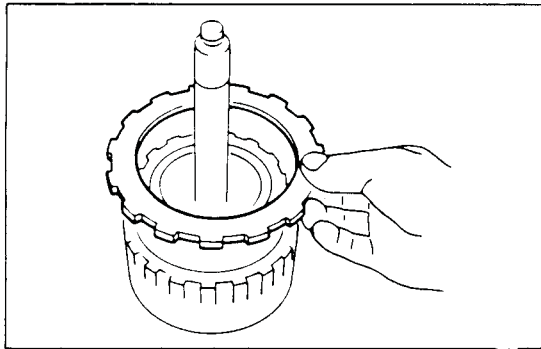

### INSTALL FRONT PLANETARY GEAR ASSEMBLY TO INTERMEDIATE SHAFT

### INSTALL PRESSURE PLATE

Install the pressure plate, facing the flat surface toward the intermediate shaft.

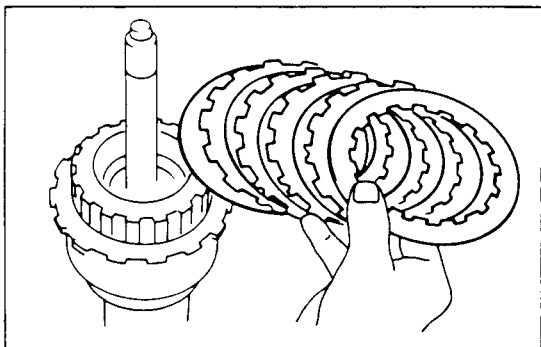

### INSTALL NO. 3 BRAKE CLUTCH PACK

Using low-pressure compressed air, blow all excess ATF from discs.

**CAUTION:** High-pressure air will damage the discs.

Install in order: Disc-plate-disc-plate-disc-plate-disc-plate-disc

**KEEP INNER RACE, APPLY TUBE, THRUST BEARING AND RACE TOGETHER**



## Transmission Case and Rear Brake Pistons

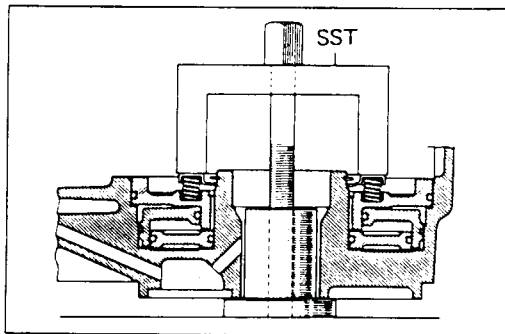
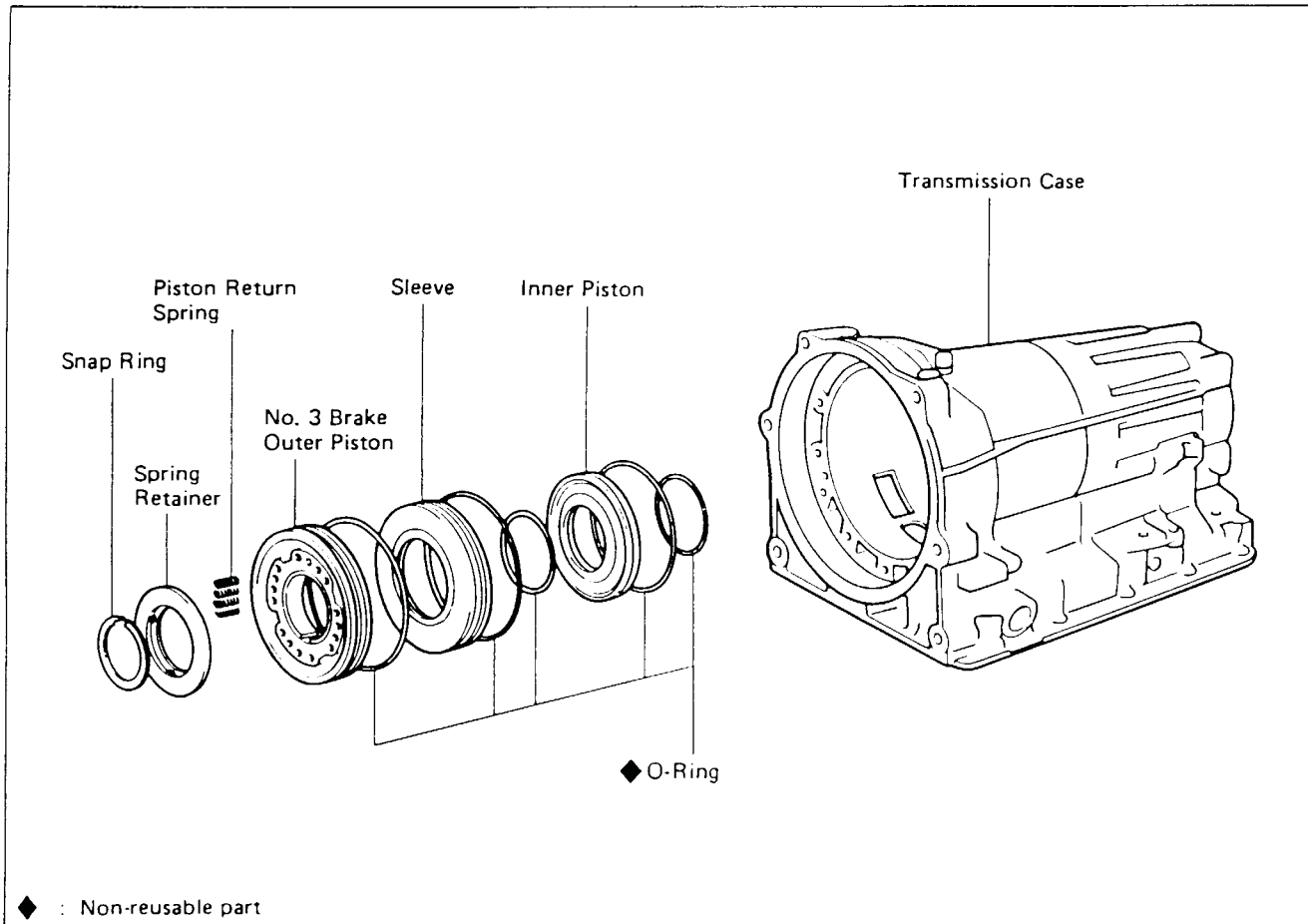

### DISASSEMBLY OF TRANSMISSION CASE AND REAR BRAKE PISTONS

#### COMPRESS RETURN SPRINGS AND REMOVE SPRING RETAINER SNAP RING

- Install the SST. Gradually and evenly tighten the bolt to compress the springs, being careful not to damage the transmission case with SST.

SST 09350-20013

- Using a screwdriver and hook, remove the snap ring.

#### REMOVE SPRING RETAINER AND SIXTEEN SPRINGS

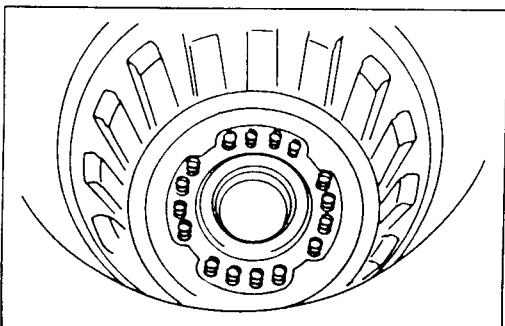





## Technical Service Information

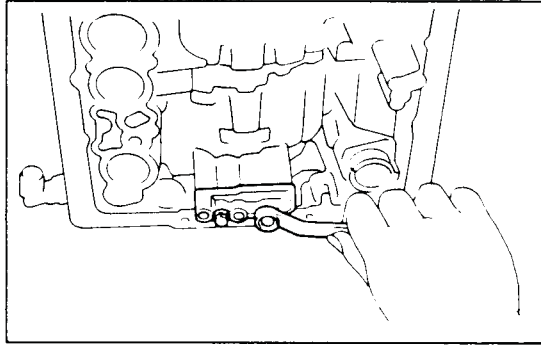

### REMOVE OUTER PISTON AND REACTION SLEEVE WITH COMPRESSED AIR

(a) Remove the adapter.

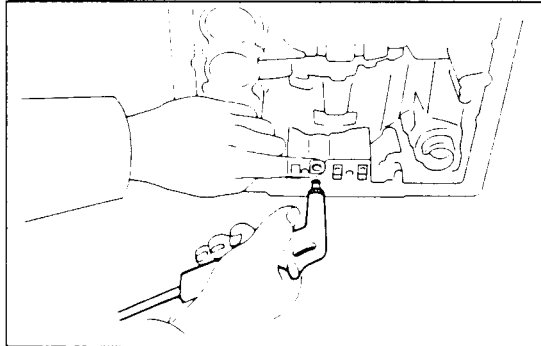

(b) Place several clean shop rags on the piston to catch the piston and sleeve. To pop them out, apply compressed air to the outer and inner piston oil holes.

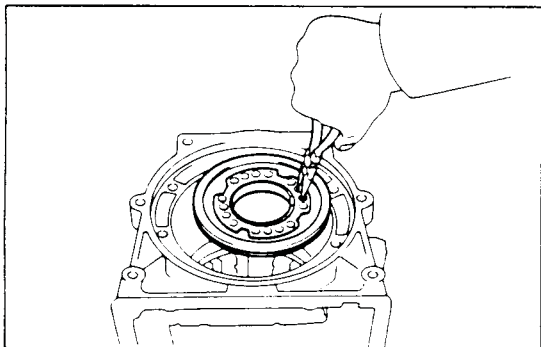

If the piston and sleeve do not pop out with the compressed air:

(c) Using needle-nose pliers, lift out the piston from the case.

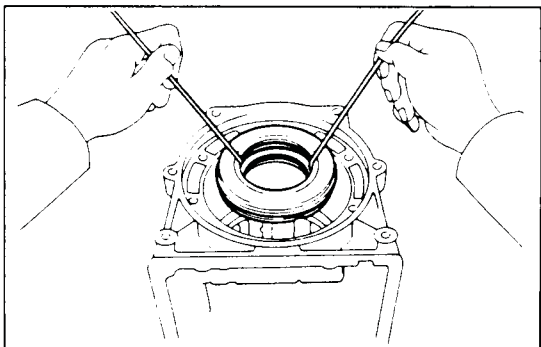

(d) Insert two long hooks behind the reaction sleeve and gradually lift it out of the case.

(e) Using hooks, lift the inner piston out of the case in the same manner.

### REMOVE O-RINGS FROM OUTER AND INNER PISTONS AND REACTION SLEEVE

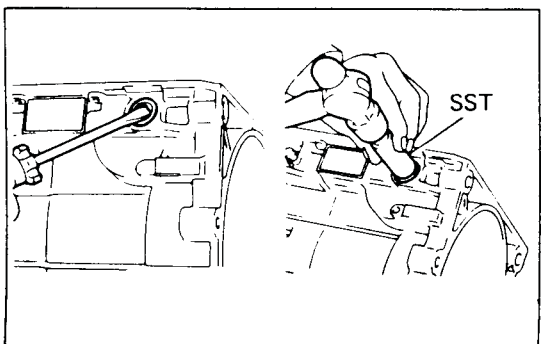

## INSPECTION OF CASE COMPONENT GROUP

### REPLACEMENT OF MANUAL SHAFT OIL SEALS

(a) Remove the manual shaft oil seals with a screwdriver.

(b) Drive in new left and right oil seals with SST.

SST 09350-20013



## Technical Service Information

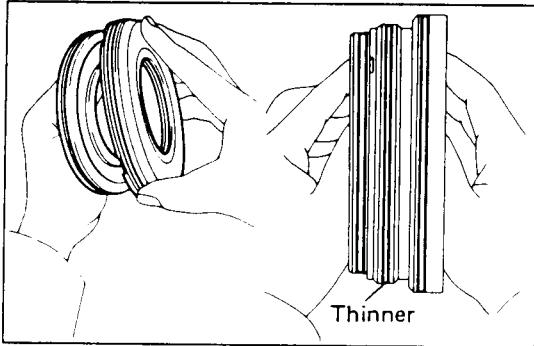

### ASSEMBLY OF TRANSMISSION CASE AND REAR BRAKE PISTONS

(See page AT-81)

#### INSTALL NEW O-RINGS ON REACTION SLEEVE AND PISTONS

**CAUTION:** The thinner O-ring goes on the outside of the reaction sleeve.

#### INSTALL INNER AND OUTER PISTONS IN REACTION SLEEVE

- Push the inner piston into the cupped side of the reaction sleeve.
- Push the outer piston onto the other side of the reaction sleeve.

#### INSTALL PISTONS AND SLEEVE IN CASE

**CAUTION:** Be careful not to damage the O-rings.

Hold the assembly with the outer piston upward (spring seats visible), and push the assembly into its bore in the case.

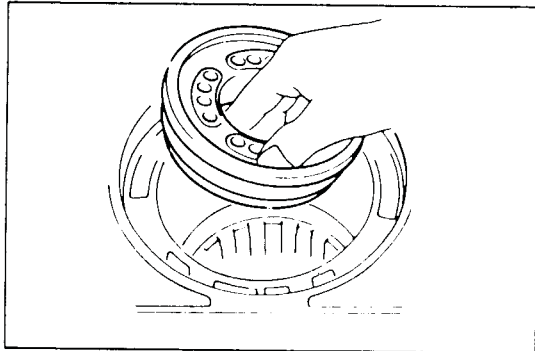

#### INSTALL SST BASE UNDER CASE

SST 09350-20013

#### INSTALL SIXTEEN PISTON RETURN SPRINGS AND SET RETAINER WITH SNAP RING IN PLACE

**NOTE:** The springs are visible through the cutout in the case, which helps position them more easily.

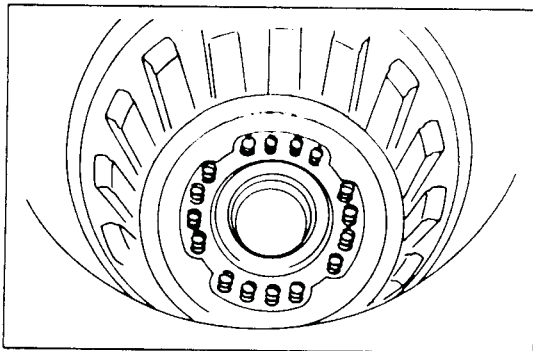

#### COMPRESS PISTON RETURN SPRINGS TO ALLOW INSTALLATION OF SNAP RING

**CAUTION:** Do not overtighten the bolt and bend the spring retainer.

- Carefully position the spring compressor on the spring retainer.
- Gradually and evenly tighten the bolt to compress the springs, being careful not to damage the transmission case with SST.

SST 09350-20013

#### INSTALL SNAP RING

- Push the ring into place with your fingers. Visually check to make sure it is fully seated and centered by the three lugs on the spring retainer.
- Remove the SST.

SST 09350-20013

#### KEEP MANUAL VALVE LEVER, PARKING LOCK PAWL AND ACCUMULATOR

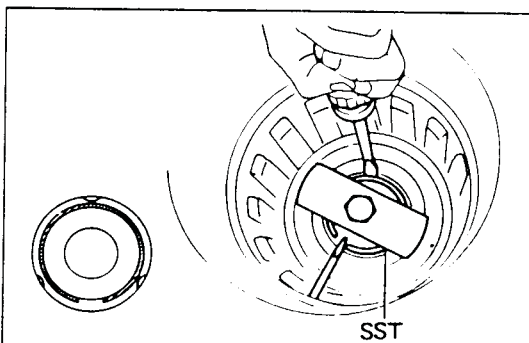
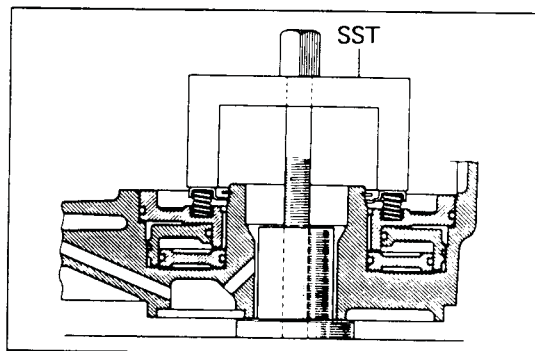



## Technical Service Information

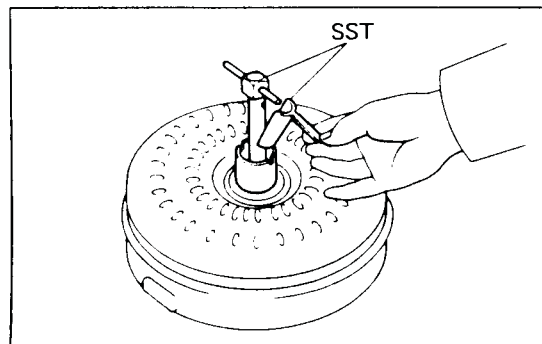
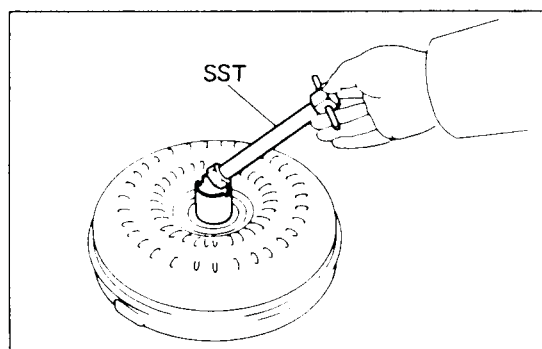
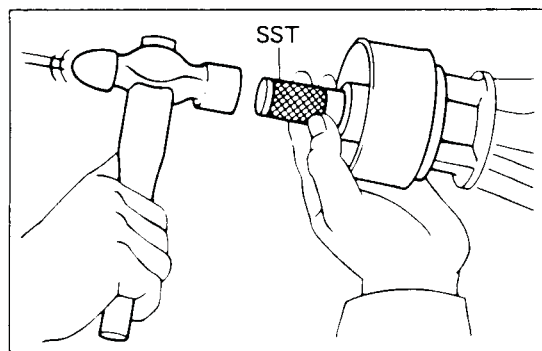
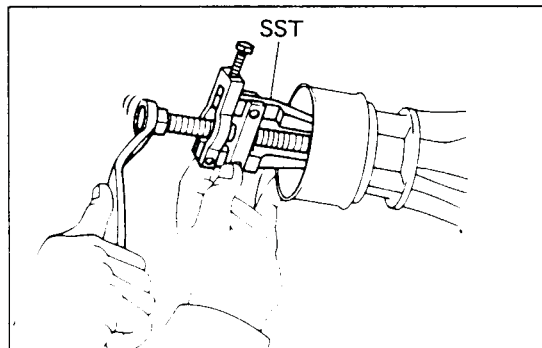
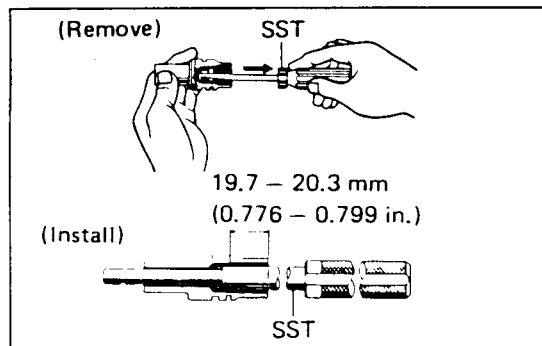

### Extension Housing

#### INSPECTION OF SPEEDOMETER GEAR AND EXTENSION HOUSING

##### IF NECESSARY, REPLACE SPEEDOMETER GEAR OIL SEAL

- Using SST, remove the oil seal.  
SST 09921-00010
- Using SST, install the new oil seal.  
SST 09201-60011

##### IF NECESSARY, REPLACE OIL SEAL AND DUST SEAL

- Using SST, remove the oil seal.  
SST 09308-10010
- Using SST, drive in a new oil seal and dust seal.  
SST 09325-20010

### Torque Converter

#### CLEAN TORQUE CONVERTER

If the transmission is contaminated, the torque converter and transmission cooler should be thoroughly flushed, using Toyota Transmission Cleaner.

#### INSPECTION OF TORQUE CONVERTER

##### INSERT SST IN END OF TORQUE CONVERTER

- Insert a turning tool in the inner race of the one-way clutch.
- Install the stopper so that it fits in the notch of the converter hub and other race of the one-way clutch.  
SST 09350-20013



# Technical Service Information

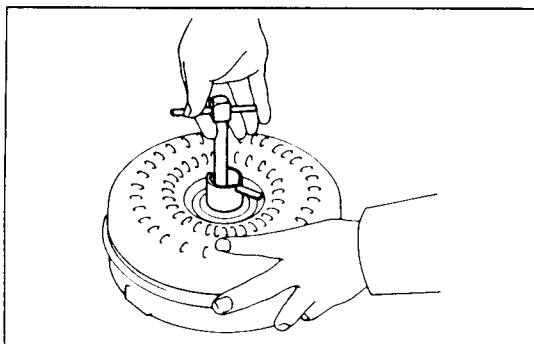

## TEST ONE-WAY CLUTCH

The clutch should lock when turned counterclockwise, and should rotate freely and smoothly clockwise. Less than 25 kg-cm (22 in.-lb, 2.5 N-m) of torque should be required to rotate the clutch clockwise. If necessary, clean the converter and retest the clutch. Replace the converter if the clutch still fails the test.

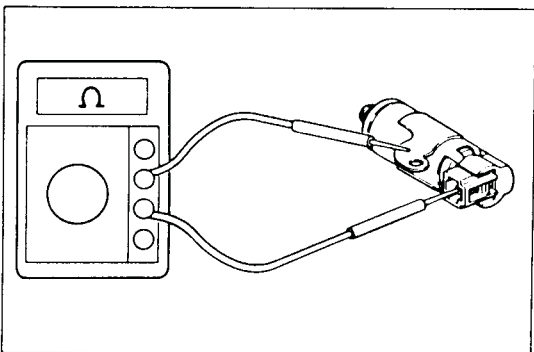

## Electrical Parts

### INSPECT SOLENOID

Check the resistance between the terminal and body.

Standard resistance: 11 – 15  $\Omega$

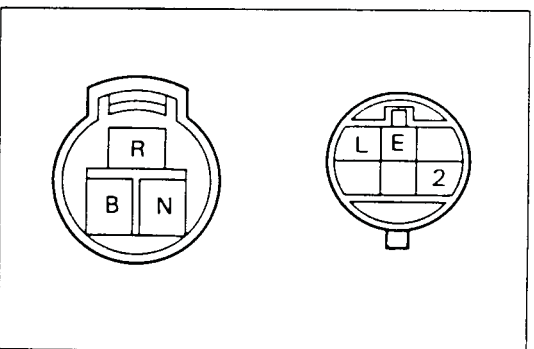

### INSPECT NEUTRAL START SWITCH

Using an ohmmeter, check the continuity of the terminals for each switch position shown in the table below.

If continuity between the terminals is not as specified, replace the switch.

Terminal Range	B	N	E	R	2	L
P	○—○					
R			○—○			
N	○—○					
2			○—○	○—○		
L			○—○	○—○	○—○	

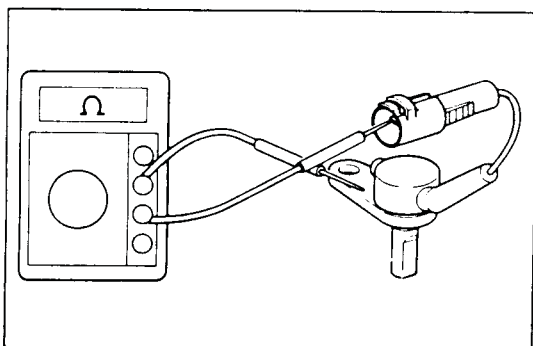

### INSPECT SPEED SENSOR

Connect an ohmmeter to the speed sensor and check that the meter deflects when the sensor is repeatedly brought close to the rotor sensor magnet and removed from it.



## ASSEMBLY OF TRANSMISSION

Disassembly, inspection and assembly of each component group have been indicated in the preceding chapter. This chapter deals with assembly of A43DE transmission.

### GENERAL ASSEMBLY NOTE:

The automatic transmission is composed of highly precision-finished parts, necessitating careful inspection before assembly because even a small nick could cause fluid leakage or affect performance.

Before assembling new clutch discs, soak them in automatic transmission fluid for at least two hours.

Apply automatic transmission fluid on sliding or rotating surfaces of the parts before assembly.

Use petroleum jelly to keep the small parts in their places.

Before assembly, make sure again that all component groups are assembled correctly. If something wrong is found in a certain component group during assembly, inspect and repair this group immediately.

Do not use adhesive cements on gaskets and similar parts.

When assembling the transmission, be sure to use new gaskets and O-rings.

Dry all parts by blowing with compressed air. Never use shop rags.

Be sure to install the thrust bearings and races in the correct direction and position.

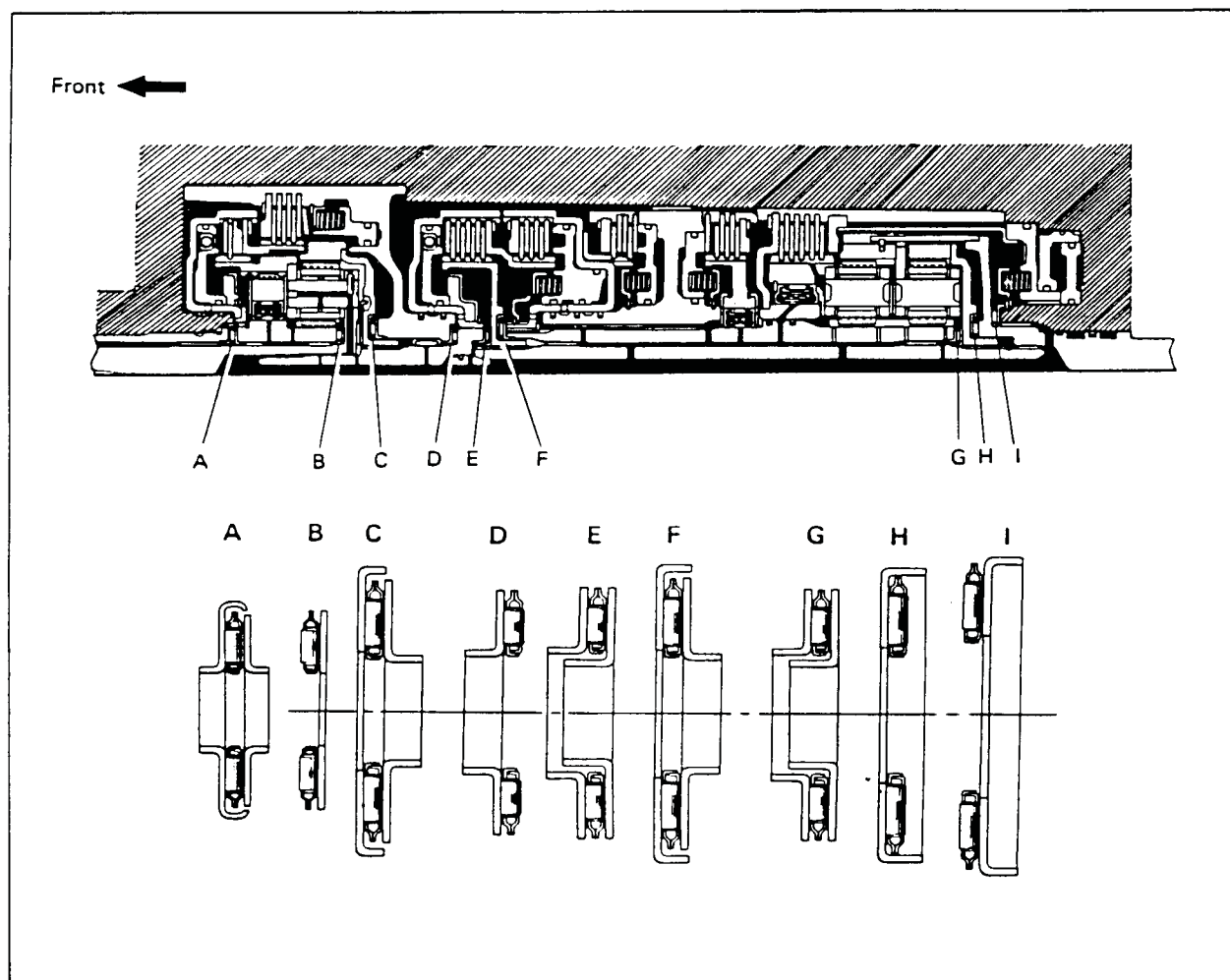

AUTOMATIC TRANSMISSION SERVICE GROUP



## Technical Service Information

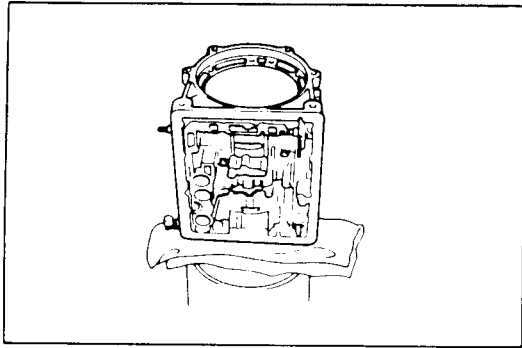

### PLACE TRANSMISSION CASE ON CYLINDER

Place the transmission on a cylindrical stand for more efficient work.

**CAUTION:** Place shop rags between the case and stand to avoid damaging the case.

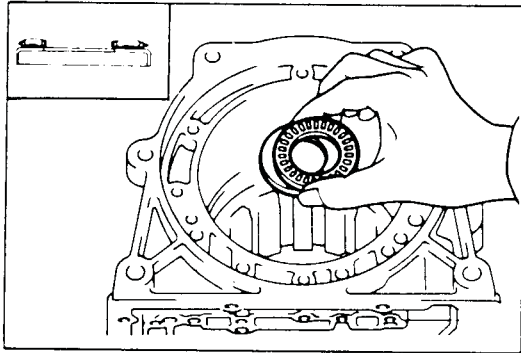

### INSTALL THRUST WASHER AND BEARING

Install the thrust washer, facing the cup side downward.

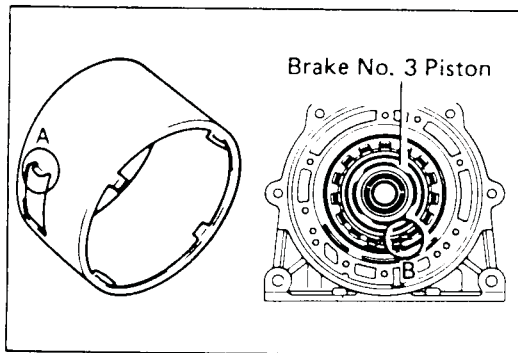

### INSTALL APPLY TUBE IN CASE

Install the tube aligning its locking tab (part A) with part B of the case.

**NOTE:** Make sure that the lips of the tube end are completely inserted onto the outer piston.

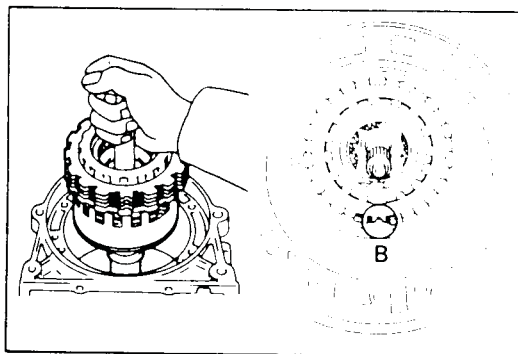

### PARTIALLY INSERT OUTPUT SHAFT ASSEMBLY INTO CASE

Align the opening notch (part A) of the clutch plates with the slot (part B) of the case.

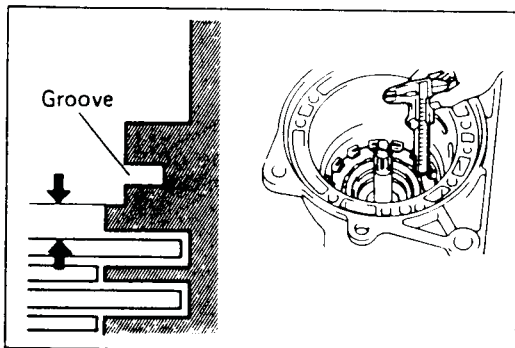

### CHECK CLUTCH PACK CLEARANCE

With the case in upright position, make sure that the clutch pack is lower than the ledge below the snap ring groove.

If the clutch pack is not lower than the ledge, components may be misassembled or there may be excess ATF on the discs.

**Standard clearance:** 0.61 – 2.64 mm  
(0.0240 – 0.1039 in.)



## Technical Service Information

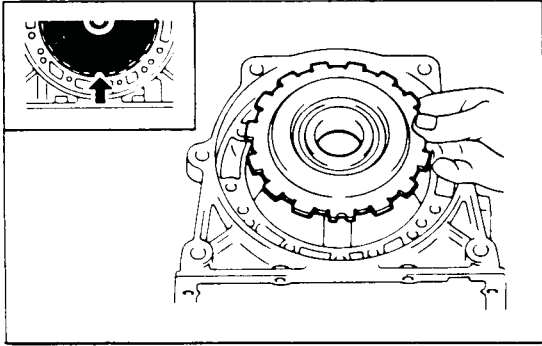

### INSTALL REACTION PLATE

Position the notched tooth of the reaction plate toward the valve body side of the case. Push it into place.

NOTE: The reaction plate is correctly installed if the snap ring groove is fully visible.

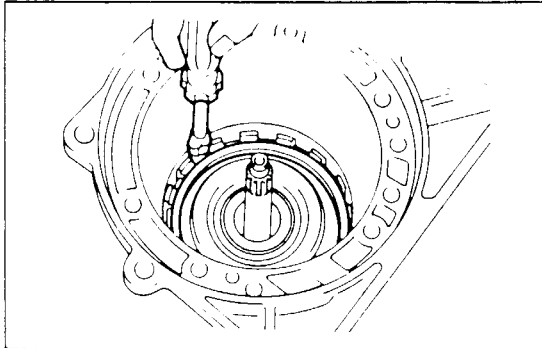

### INSTALL SNAP RING

Use a large screwdriver to compress the snap ring. Push it into place by hand. Work around the case. Visually check to make sure that the ring is fully seated. Make sure that the ends of the snap ring are between the lugs.

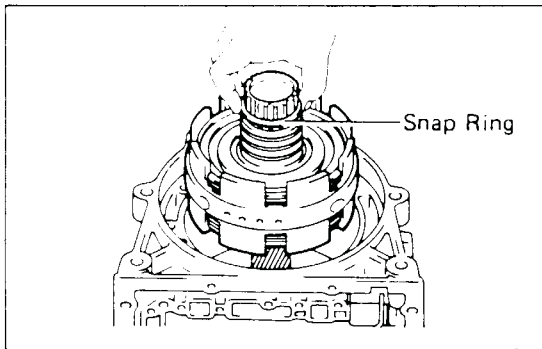

### PUSH CENTER SUPPORT ASSEMBLY INTO CASE

Align the oil hole and bolt hole of the center support with those of the body side and insert.

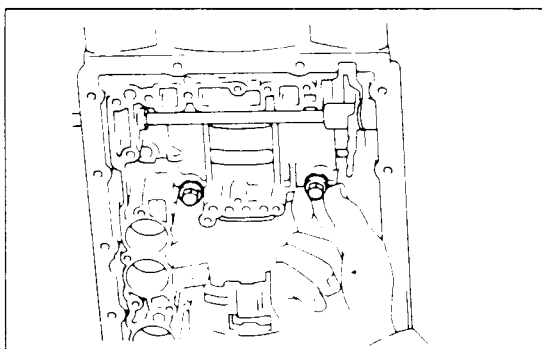

### INSTALL TWO CENTER SUPPORT BOLTS WITH WAVE WASHERS

Align the center support with holes in the case and install the two bolts finger tight.

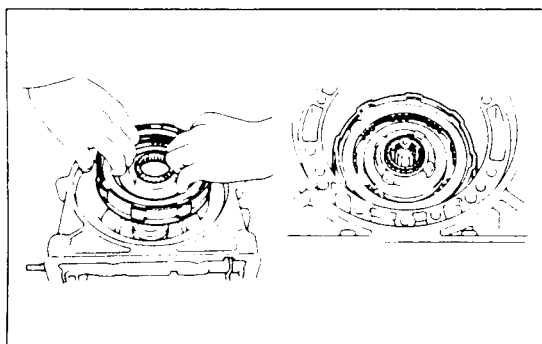

### INSTALL REAR CLUTCH IN CASE

Rotate the clutch to mesh the hub with the center support.

### CHECK FOR CORRECT INSTALLATION OF REAR CLUTCH

If the rear clutch is fully meshed with the center support, the splined center of the clutch will be flush with the end of the sun gear shaft.



## Technical Service Information

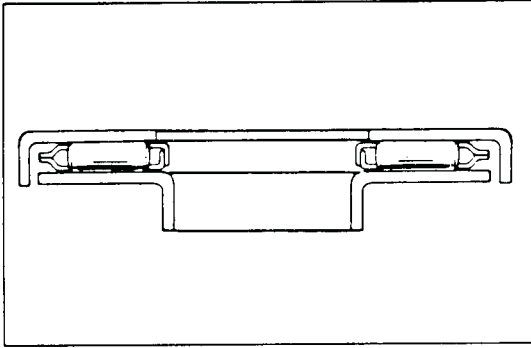

### INSTALL NEEDLE BEARING RACE OVER SPLINED END OF REAR CLUTCH IN CASE

Coat the parts with petroleum jelly to keep them in place. Position the lip of the race toward the rear clutch.

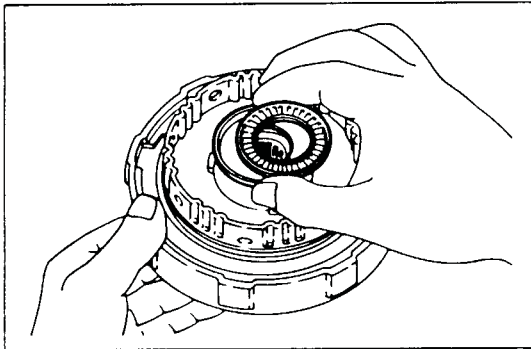

### INSTALL THRUST BEARING AND RACE ON FRONT CLUTCH

Coat the parts with petroleum jelly to keep them in the place. Position the lip of the race outward.

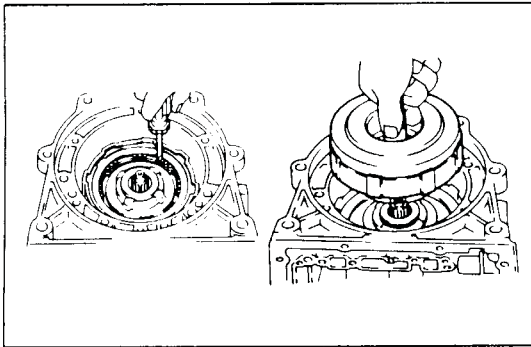

### INSTALL FRONT CLUTCH ASSEMBLY IN CASE

Align the flukes of the rear clutch discs and mesh them with front clutch hub. Push the front clutch assembly into the case.

**CAUTION:** Be careful that the thrust bearing does not fall out.

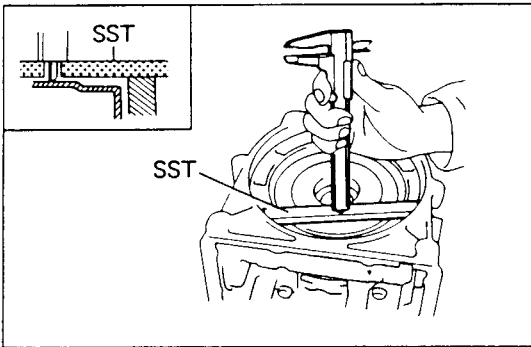

### CHECK CORRECT INSTALLATION OF FRONT CLUTCH

Set SST on the transmission case as shown in the figure. Measure the distance between the top surface of the SST and front clutch assembly. If the distance corresponds to that during disassembly, the front clutch is installed correctly.

SST 09350-20013

Height: Measured value minus SST width =  
Approx. 2mm (0.08 in.)

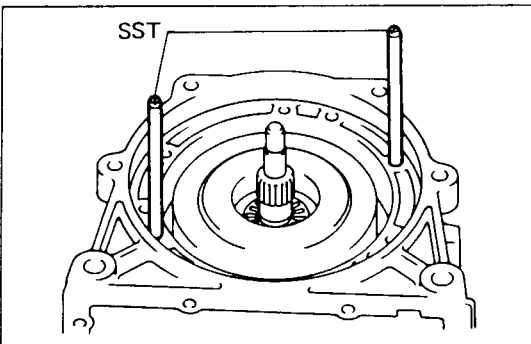

### INSTALL THRUST BEARING ON FRONT CLUTCH

Coat the thrust bearing with petroleum jelly and set it into place.

### INSTALL SST ON CASE

Finger tighten the SST on the transmission case.

SST 09350-20013





## Technical Service Information

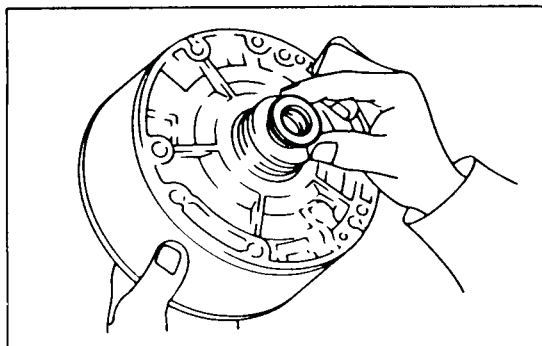

### INSTALL THRUST WASHER ON OVERDRIVE CASE END

Coat the thrust washer with petroleum jelly and set it into place facing the lip side toward the overdrive case.

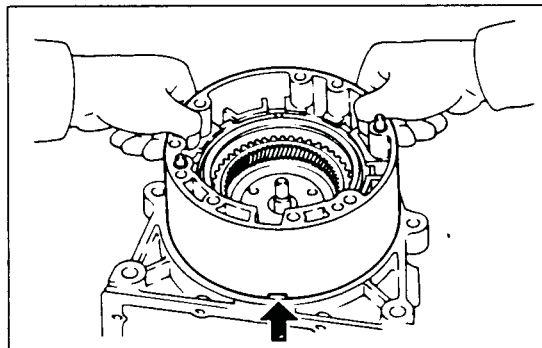

### INSERT OVERDRIVE CASE INTO TRANSMISSION CASE

Insert the overdrive case gently through the two guide bolts (SST) with the circled part in the figure facing in the direction indicated.

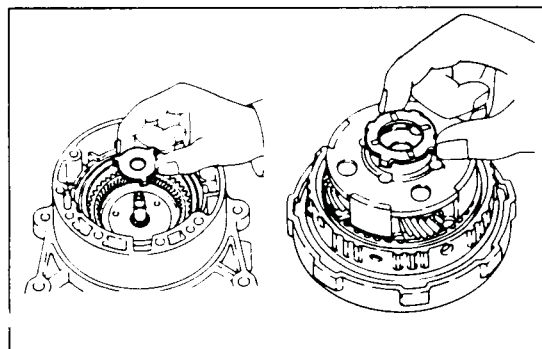

### INSTALL TWO THRUST WASHERS

Coat the thrust washers with petroleum jelly. Install one thrust washer on the overdrive case and the other one on the overdrive clutch.

NOTE: The washer lugs should be inserted in the holes.

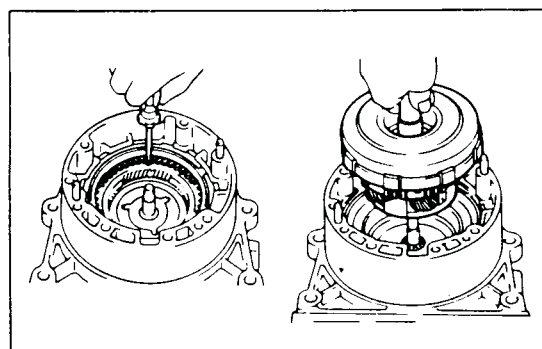

### INSTALL OVERDRIVE CLUTCH IN CASE

Align the flukes of the discs in the overdrive case. Align the flukes with the slots of the overdrive clutch and press the overdrive clutch into the overdrive case.

CAUTION: Be careful that the thrust washer does not fall out.

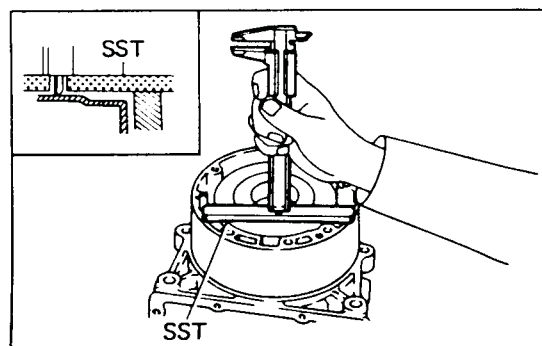

### CHECK CORRECT INSTALLATION OF OVERDRIVE CLUTCH

Set SST on the overdrive case as shown in the figure. Measure the distance between the top surface of SST and the overdrive clutch. If the distance corresponds to that during disassembly, the overdrive clutch is installed correctly.

SST 09350-20013

Height: Measure value minus SST width =  
Approx. 3.5 mm (0.138 in.)



## Technical Service Information

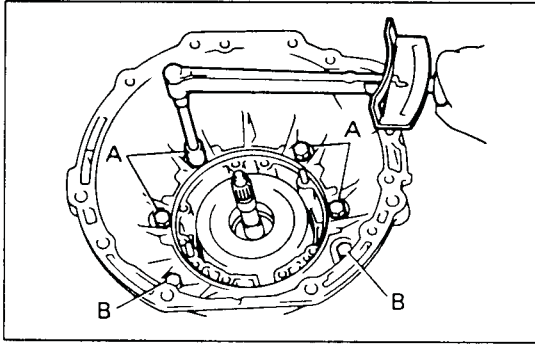

### INSTALL O-RING ON OVERDRIVE CASE

#### INSTALL CONVERTER HOUSING

Install the two 12-mm bolts at B and four 10-mm bolts at A and tighten them.

**Torque:** A bolts 345 kg-cm (25 ft-lb, 34 N·m)  
B bolts 580 kg-cm (42 ft-lb, 57 N·m)

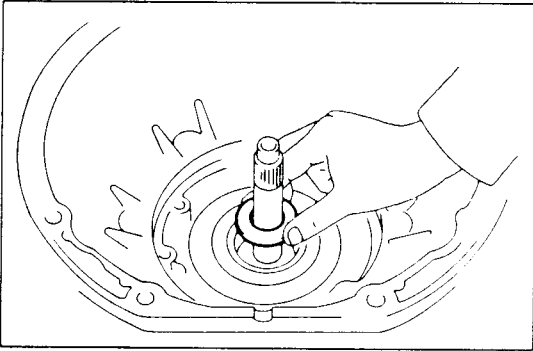

### INSTALL RACE ON OVERDRIVE CLUTCH

Install the thrust washer, facing the lip side outward.

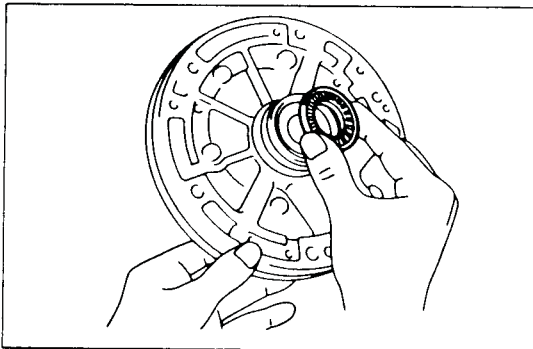

### INSTALL THRUST BEARING ON FRONT OIL PUMP

Coat the thrust washer with petroleum jelly and install the washer side toward the pump body together with the bearing.

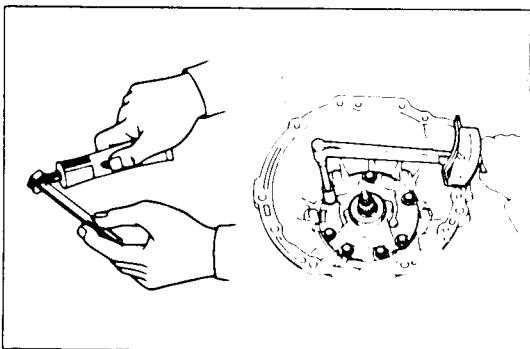

### INSTALL FRONT OIL PUMP

- Install the oil pump gently through the two guide pins, being careful that the thrust washer does not fall out.
- Coat the five set bolts with seal packing and finger tighten them.
- Using a screwdriver, remove the SST, and install the two set bolts coated with seal packing.

SST 09350-20013

- Tighten the set bolts gradually and uniformly.

**Torque:** 215 kg-cm (16 ft-lb, 21 N·m)

### TIGHTEN TWO CENTER SUPPORT BOLTS

Tighten the bolts alternately in 70 kg-cm (61 in. lb, 6.9 N·m) increments.

**Torque:** 260 kg-cm (19 ft-lb, 25 N·m)

**NOTE:** First tighten the accumulator side bolt.

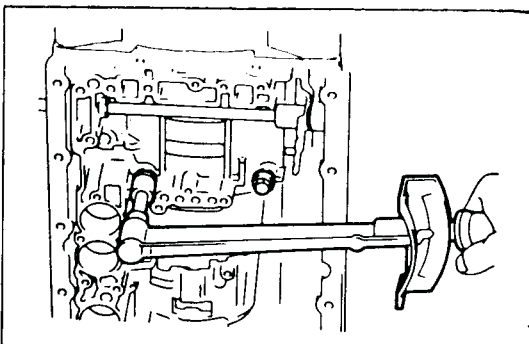



## Technical Service Information

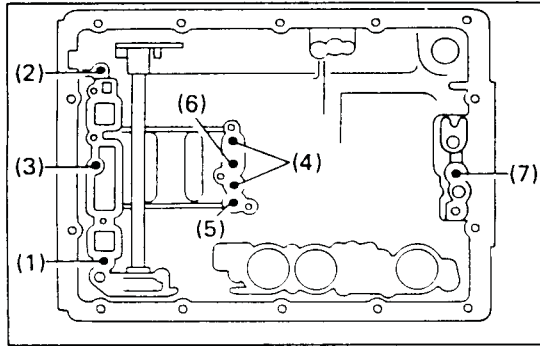

### CHECK OPERATION OF PISTONS

Blow low-pressure compressed air into the passages indicated on the figure and listen for noise from piston movement.

- (1) Overdrive clutch
- (2) Overdrive brake
- (3) Front clutch
- (4) Rear clutch
- (5) Brake No. 1
- (6) Brake No. 2
- (7) Brake No. 3

If pistons do not move, disassemble and inspect.

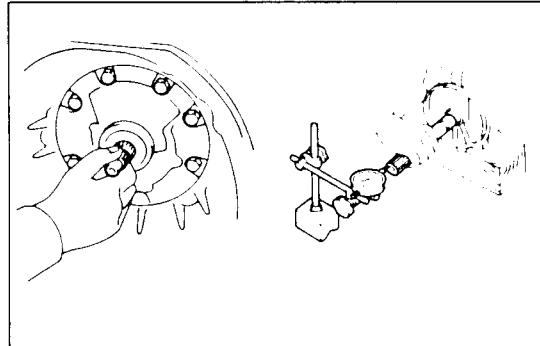

### CHECK INPUT SHAFT AND OUTPUT SHAFT

- (a) Make sure that the input shaft has play in axial direction and that it turns.
- (b) Make sure that the output shaft has thrust play in axial direction.

Thrust play: 0.3 – 0.9 mm (0.012 – 0.035 in.)

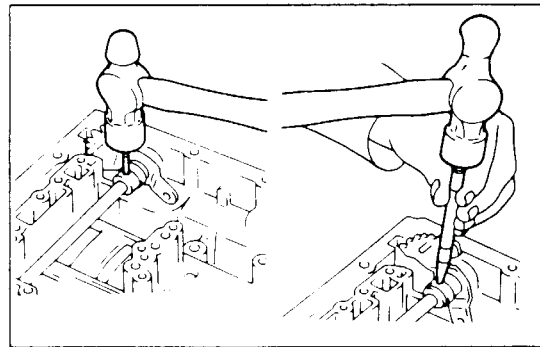

### IF NECESSARY, INSTALL MANUAL VALVE LEVER SHAFT INTO CASE

- (a) Assemble a new collar to the manual valve lever.  
NOTE: Always replace the collar with a new one.
- (b) Install the manual valve lever shaft to the transmission case through the manual valve lever.
- (c) Drive in the roll pin with the slot at right angle to the shaft.
- (d) Match the collar hole to the lever staking hollow and stake the collar to the lever.

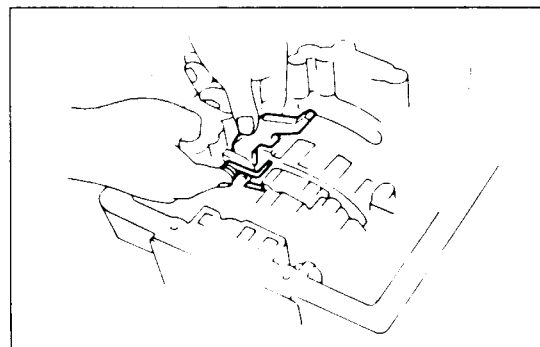

### INSTALL PARKING LOCK PAWL, PIVOT PIN AND SPRING IN CASE

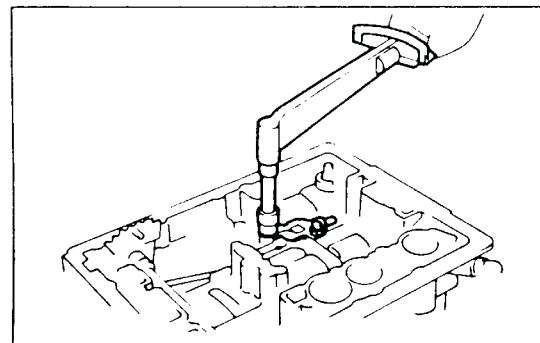

### INSTALL PARKING LOCK PAWL BRACKET ON CASE

Make sure the collar on the control rod is facing toward the front of the transmission.

Tighten the two bolts. Make sure the pawl moves freely.

NOTE: It is possible for the bracket to be installed too far forward, where it will bind the pawl.

Torque: 75 kg-cm (65 in.-lb, 7.4 N·m)



# Technical Service Information

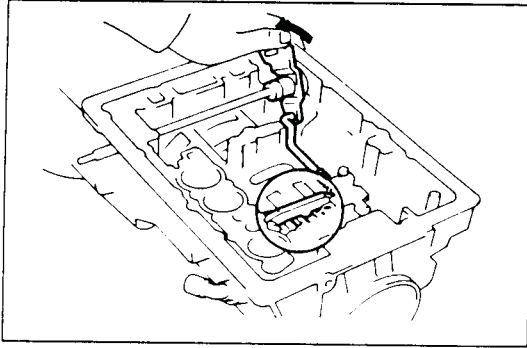

## CHECK OPERATION OF PARKING LOCK PAWL

Make sure the planetary gear output shaft is locked when the manual valve lever is in "P" range.

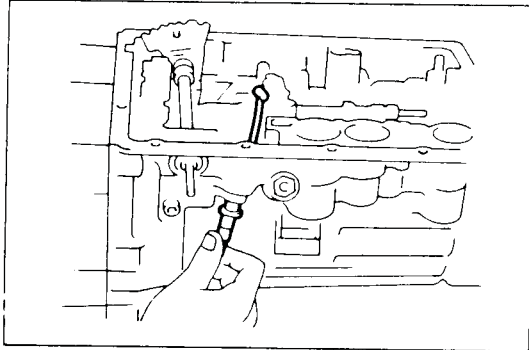

## INSTALL NEW O-RING ON THROTTLE CABLE FITTING

### INSTALL THROTTLE CABLE IN CASE

Push the cable through the case, being careful not to damage the O-ring. Check for full seating.

**CAUTION:** In subsequent work, be careful not to roll the case over the cable and break the cable fitting.

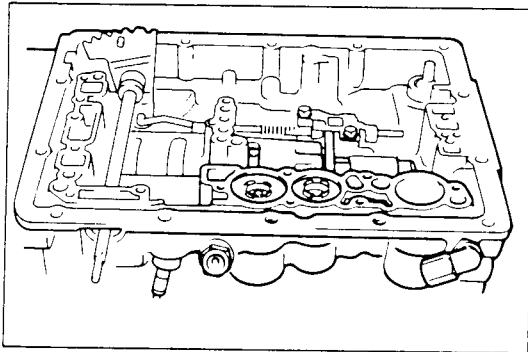

## INSTALL ACCUMULATOR PISTON AND SPRINGS

Spring		Free length	Outer diameter	Wire diameter	Color
B <sub>2</sub>	Upper	50.68 (1.9953)	20.00 (0.7874)	2.80 (0.1102)	Light Gray
	Lower	35.13 (1.3831)	16.16 (0.6362)	1.30 (0.0512)	Red
C <sub>2</sub>	Upper	43.56 (1.7150)	14.30 (0.5630)	1.80 (0.0709)	Blue
	Lower	32.73 (1.2886)	14.80 (0.5827)	1.30 (0.0512)	Green
C <sub>1</sub>		64.68 (2.5465)	17.50 (0.6890)	2.00 (0.0787)	None

## PLACE VALVE BODY ON TRANSMISSION

Make sure the accumulator pistons are pressed fully into the bore. Align the manual valve with the pin on the manual shift lever, and lower valve body into place.

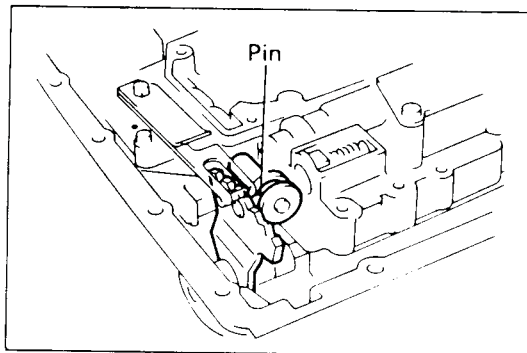

## LIFT SIDE OF VALVE BODY AND ATTACH THROTTLE CABLE

- While holding the cam down with your fingers, slip the cable end into the slot.
- Make sure that the B<sub>2</sub> and C<sub>2</sub> accumulator piston springs is installed onto the piston.

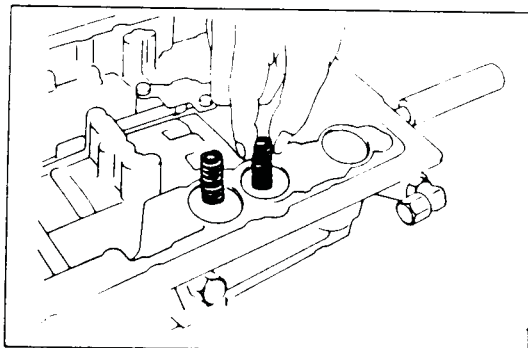



## Technical Service Information

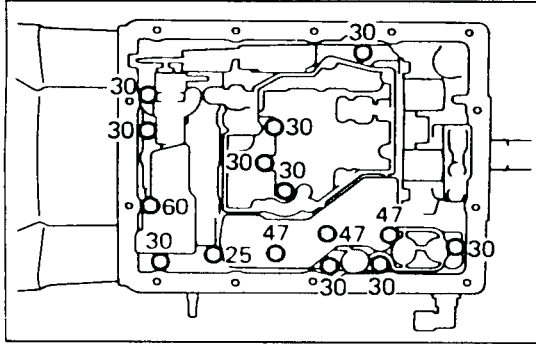

### INSTALL FIFTEEN BOLTS IN VALVE BODY

Install the bolts as shown.

Torque: 100 kg-cm (7 ft-lb, 10 N·m)

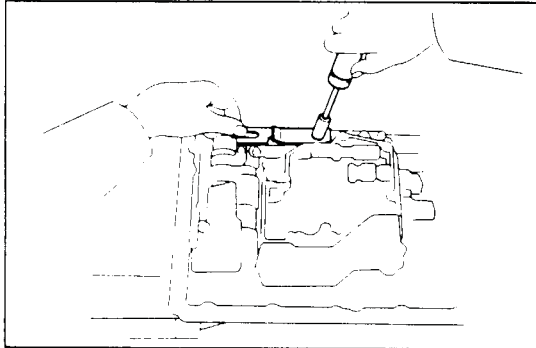

### INSTALL DETENT SPRING

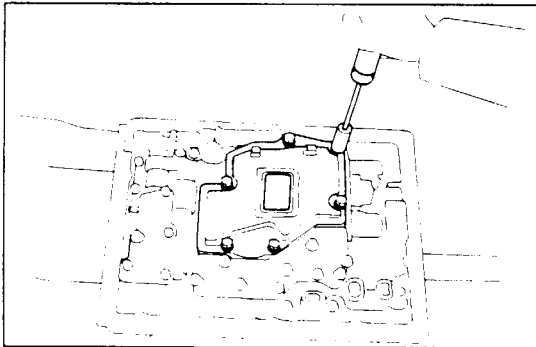

### INSTALL OIL STRAINER

Torque: 55 kg-cm (48 in.-lb, 5.4 N·m)

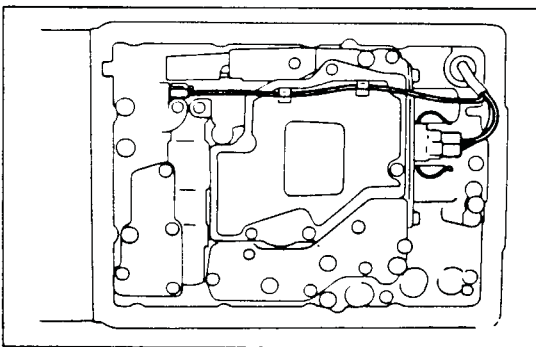

### CONNECT SOLENOID WIRING TO EACH SOLENOID

- Push the solenoid wiring through in the transmission case and connect the terminals to each solenoid.
- Clamp the wiring to the oil screen.
- Install the gromet for the wiring with the plate.

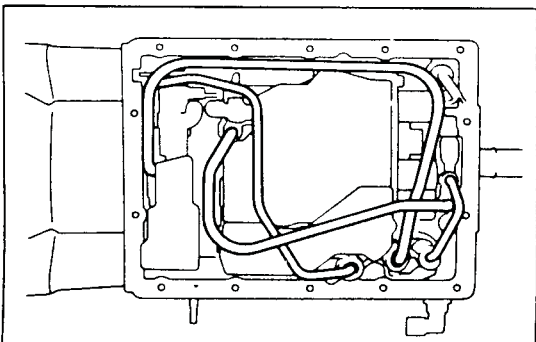

### INSTALL OIL TUBES

Press the tubes by hand into the positions indicated in the figure. Make sure that the oil tubes do not interfere with the oil pan.



## Technical Service Information

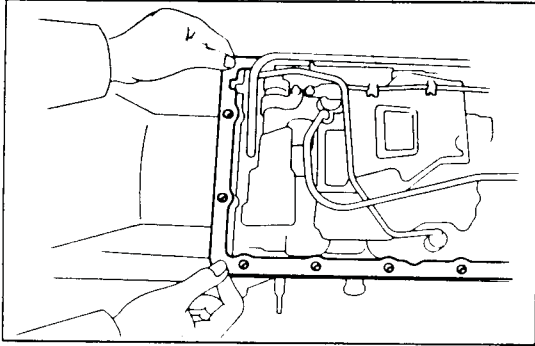

### INSTALL TWO MAGNETS IN PAN AND INSTALL OIL PAN WITH NEW GASKET

(a) Align the cut part of the gasket and case.

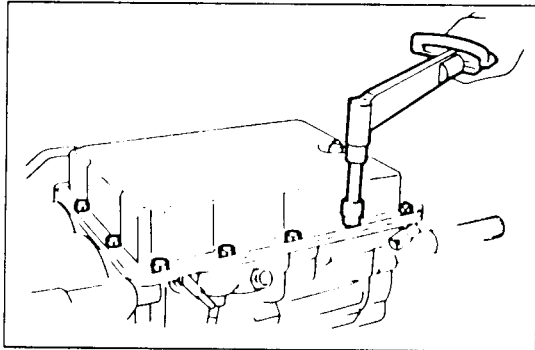

(b) Install the oil pan.

Torque: 45 kg-cm (39 in.-lb, 4.4 N·m)

**CAUTION:** Make sure that the two magnets do not interfere with the oil tubes or valve body.

### INSTALL DRAIN PLUG WITH NEW GASKET

Torque: 205 kg-cm (15 ft-lb, 20 N·m)

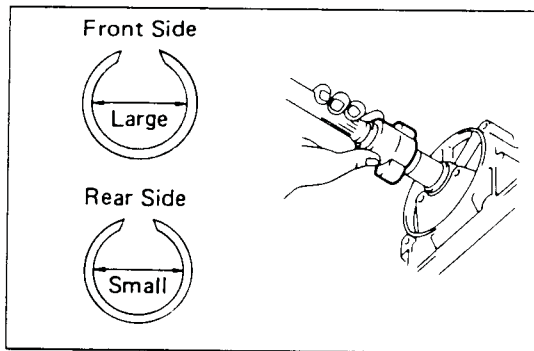

### INSTALL SENSOR ROTOR AND SPEEDOMETER DRIVE GEAR

**NOTE:** Install the larger diameter snap ring at the front side.

- (a) Install the larger snap ring and woodruff key onto the shaft.
- (b) Install the sensor rotor.

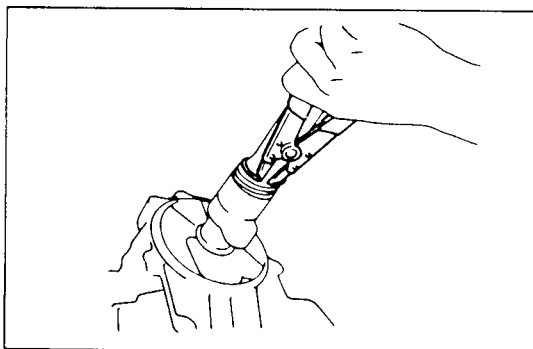

(c) Install the lock ball.

(d) Slide the speedometer gear on the shaft.

(e) Using snap ring pliers, install the outer snap ring.

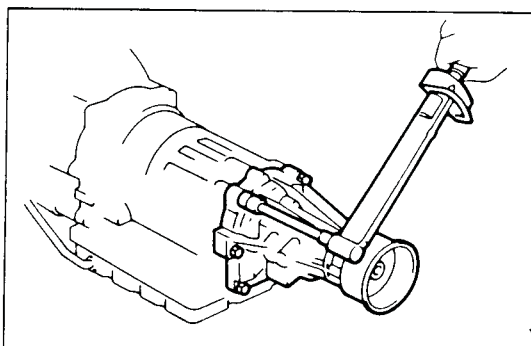

### INSTALL EXTENSION HOUSING WITH NEW GASKET

Do not use the gasket sealer. Install the housing with four long bolts and two short bolts. Tighten the bolts.

Torque: 345 kg-cm (25 ft-lb, 34 N·m)



## Technical Service Information

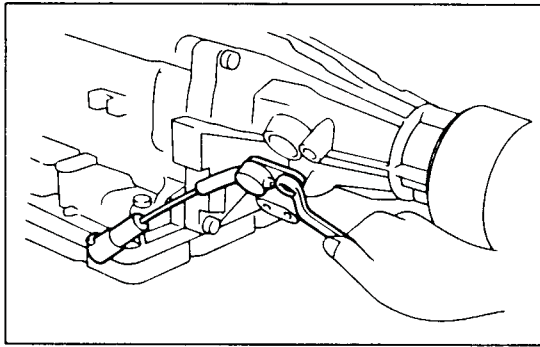

### INSTALL SPEED SENSOR IN EXTENSION HOUSING

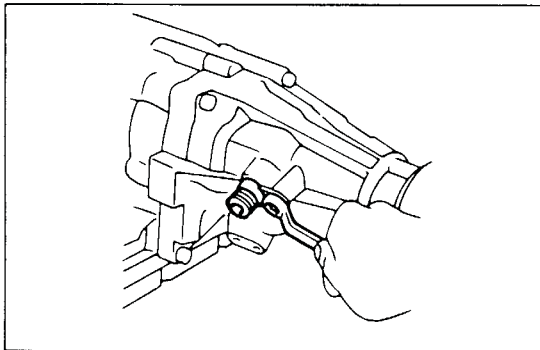

### INSTALL NEW O-RINGS, BUSHING AND SPEEDOMETER DRIVEN GEAR TO SHAFT SLEEVE

### INSTALL SPEEDOMETER DRIVEN GEAR ASSEMBLY IN EXTENSION HOUSING

Insert the shaft sleeve assembly into the housing. Install the lock plate with the bolt and lock washer.

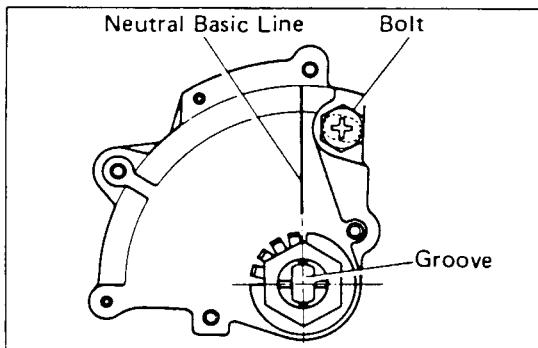

### INSTALL NEUTRAL START SWITCH

- Slide the neutral start switch onto the control shaft.
- Install the grommet facing the groove toward the switch body and then install the washer and nut.
- Move the switch so that the slit in the switch and neutral basic line match up. Tighten the bolt and nut.

Torque: Bolt 55 kg-cm (48 in.-lb, 5.4 N·m)  
Nut 70 kg-cm (61 in.-lb, 6.9 N·m)

### INSTALL SHIFT HANDLE

## A40 A41

### Valve Body

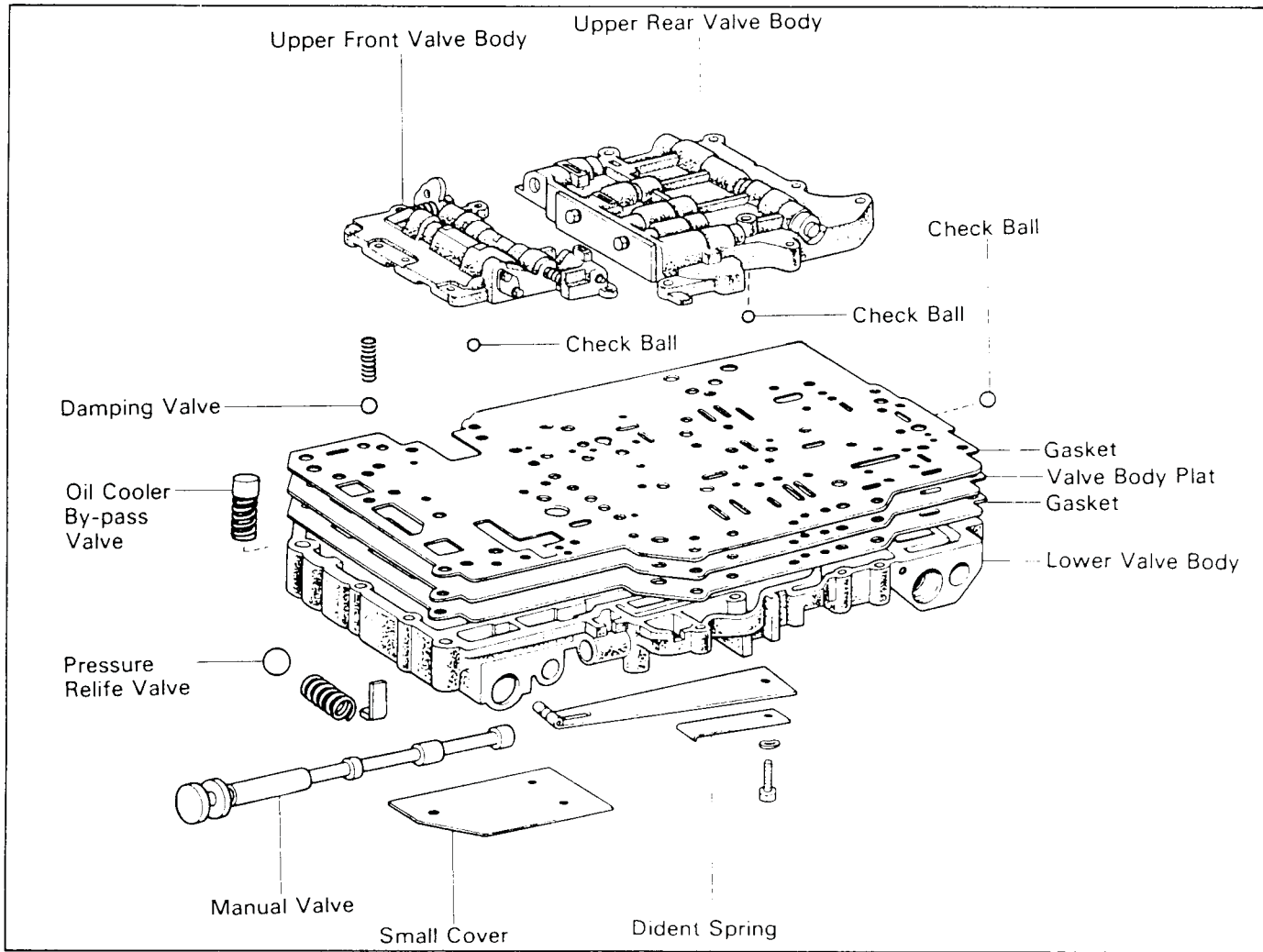





# Technical Service Information (Lower Valve Body)

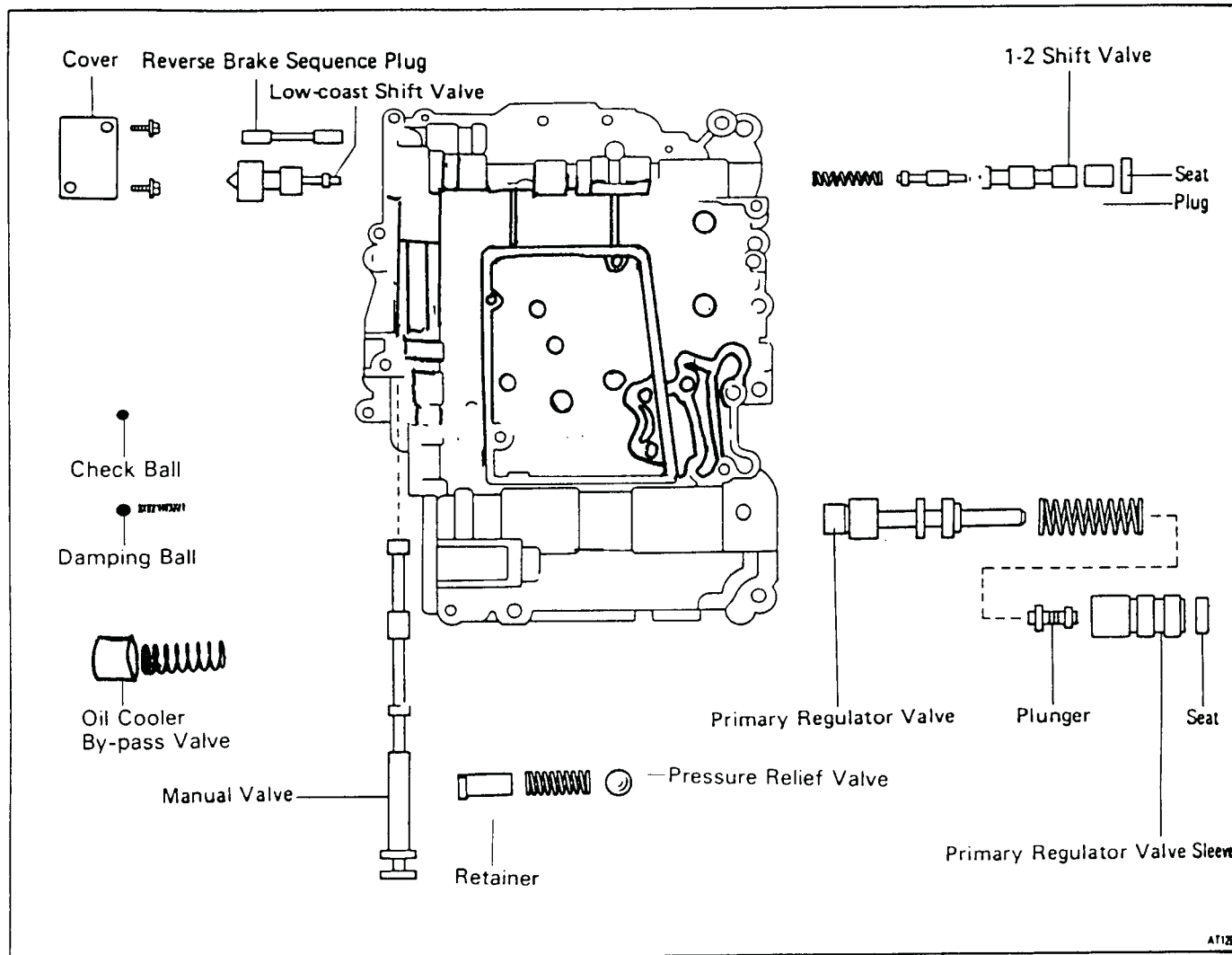

## INSPECT VALVE SPRINGS

Check for damage, squareness, rust and distorted coils. Measure the spring free height and replace if less than that shown below.

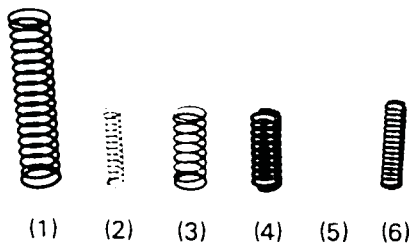

	Free height	mm (in.)
(1) Primary regulator valve	73.32	(2.8866)
(2) 1-2 shift valve	34.62	(1.3630)
(3) Check valve (for oil cooler)	30.65	(1.2067)
(4) Pressure relief valve ball	32.14	(1.2654)
(5) Damping ball	19.50	(0.7677)
(6) Reverse brake sequence valve	37.55	(1.4783)



# Technical Service Information

## (Upper Front Valve Body)

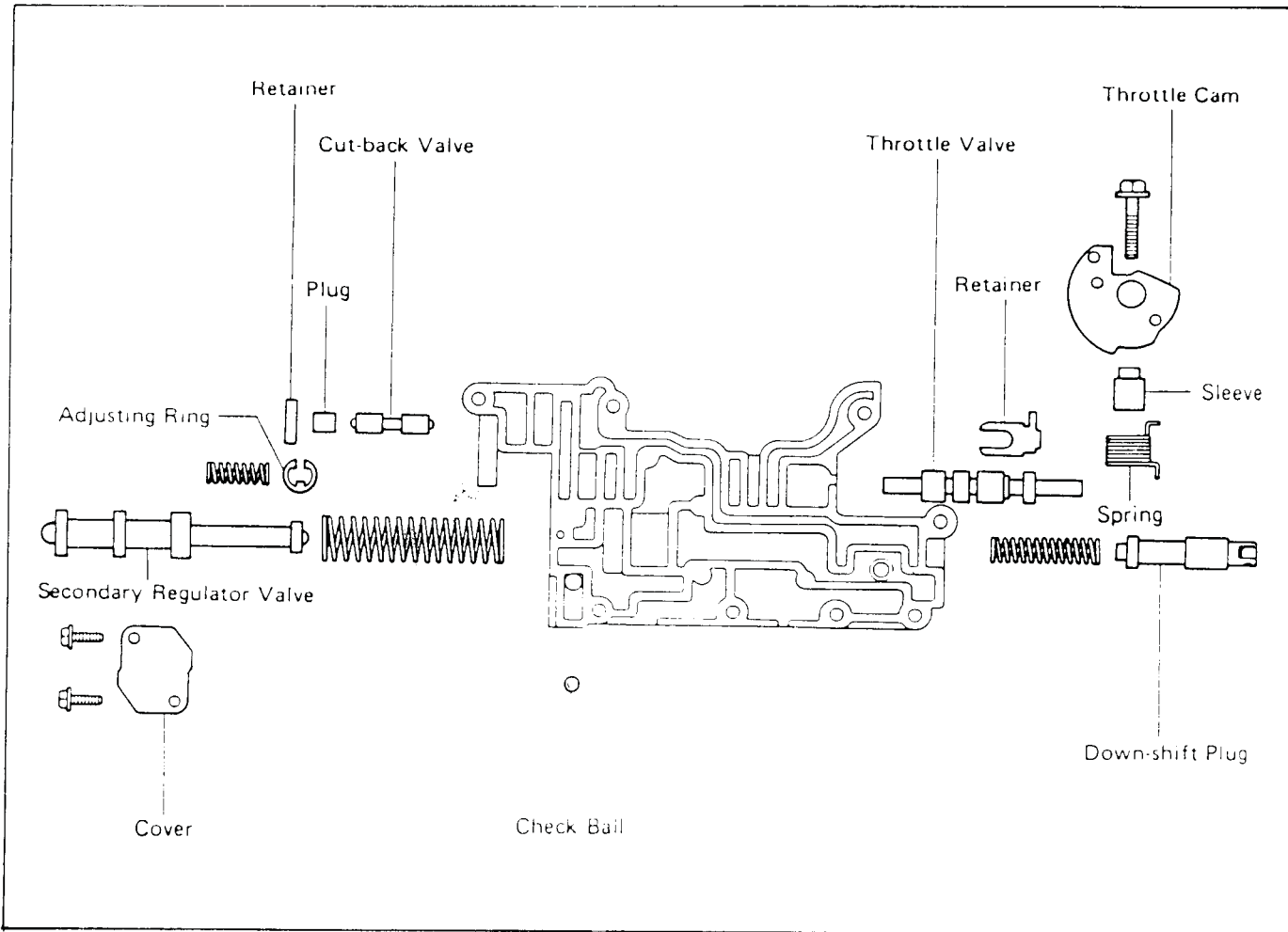

### INSPECT VALVE SPRINGS

Check for damage, squareness, rust and collapsed coils.  
Measure the spring free height and replace if less than that shown below.

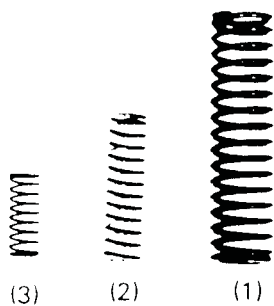

		Free height	mm (in.)
(1)	Secondary regulator valve	74.83	(2.9461)
(2)	Down-shift plug	39.71	(1.5634)
(3)	Throttle valve	19.24	(0.0757)

# Technical Service Information (Upper Rear Valve Body)

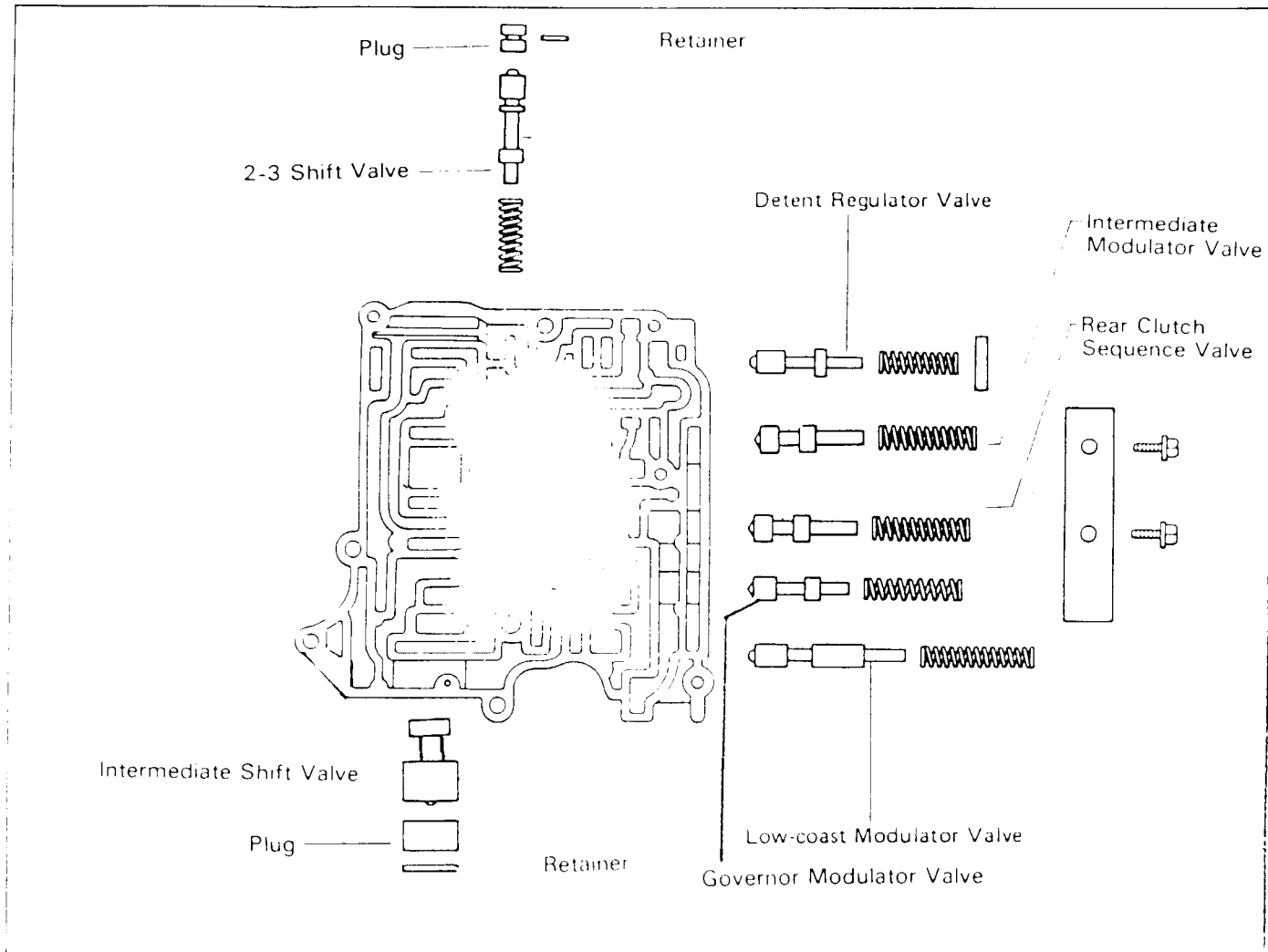

## INSPECT VALVE SPRINGS

Check for damage, squareness, rust and collapsed coils. Measure the spring free height and replace if less than the shown below.

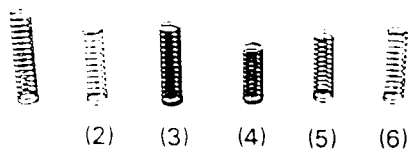

	Free height mm (in.)
(1) Low-coast modulator valve	42.35 (1.6673)
(2) Rear clutch sequence valve	37.55 (1.4783)
(3) Governor modulator valve	36.07 (1.4201)
(4) 2-3 shift valve	35.10 (1.3819)
(5) Detent regulator valve	32.08 (1.2630)
(6) Intermediate modulator valve	25.60 (1.0079)



# Technical Service Information

1973-76

TOYOTA

A40  
LOWER

A40  
UPPER

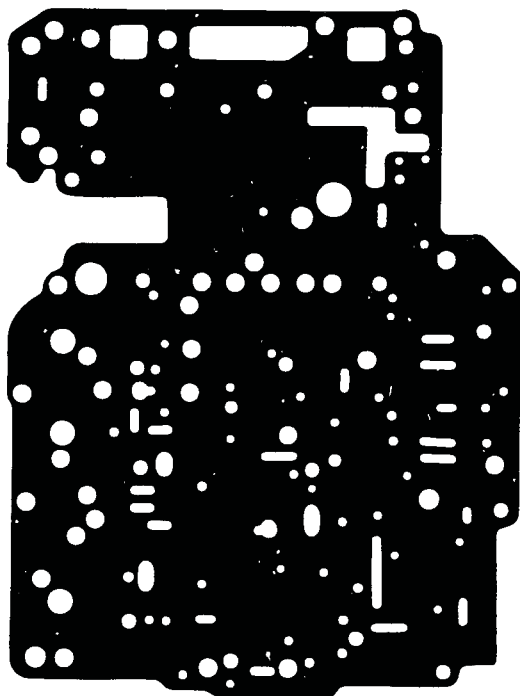
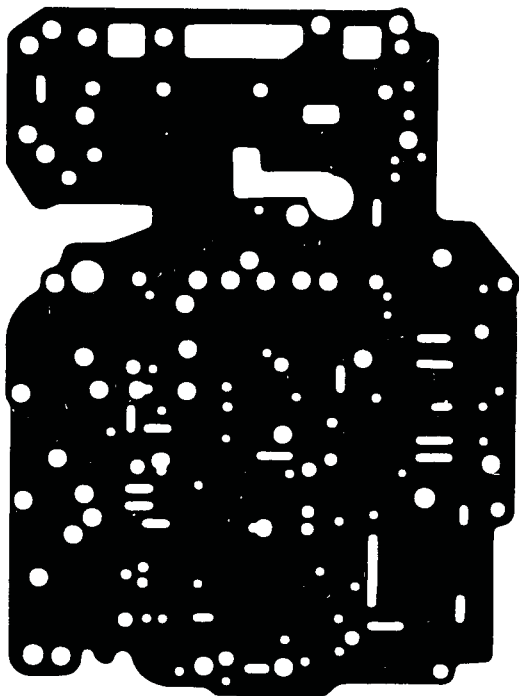

TOYOTA-VOLVO  
A40/41 AW-55

LOWER

UPPER

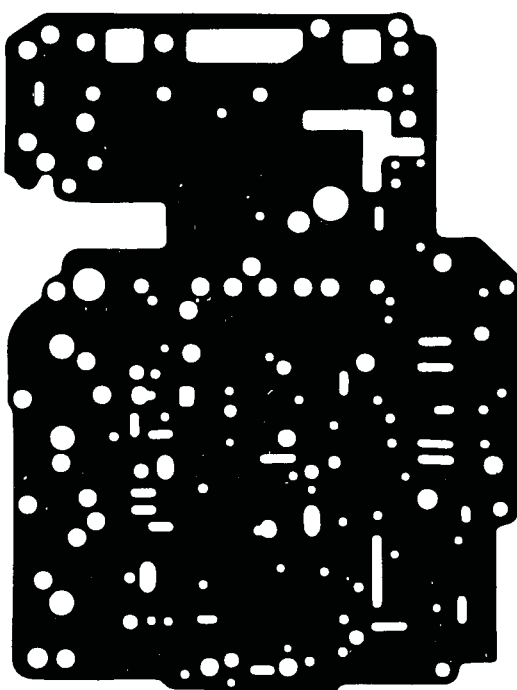
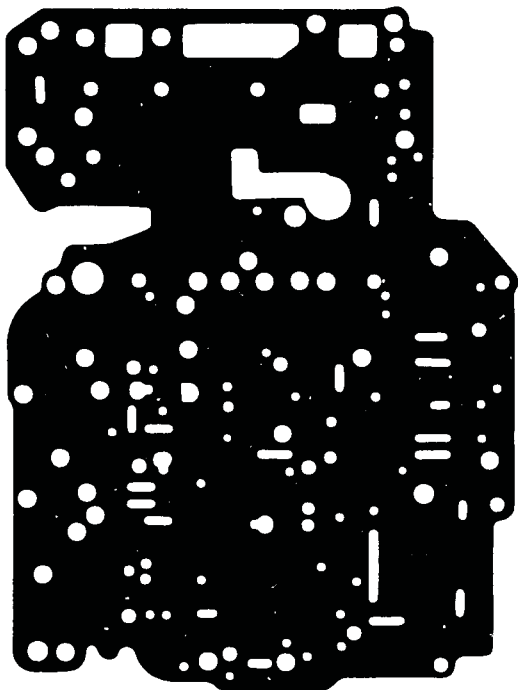

AUTOMATIC TRANSMISSION SERVICE GROUP

VOLVO - 6 CYLINDER  
ENG.

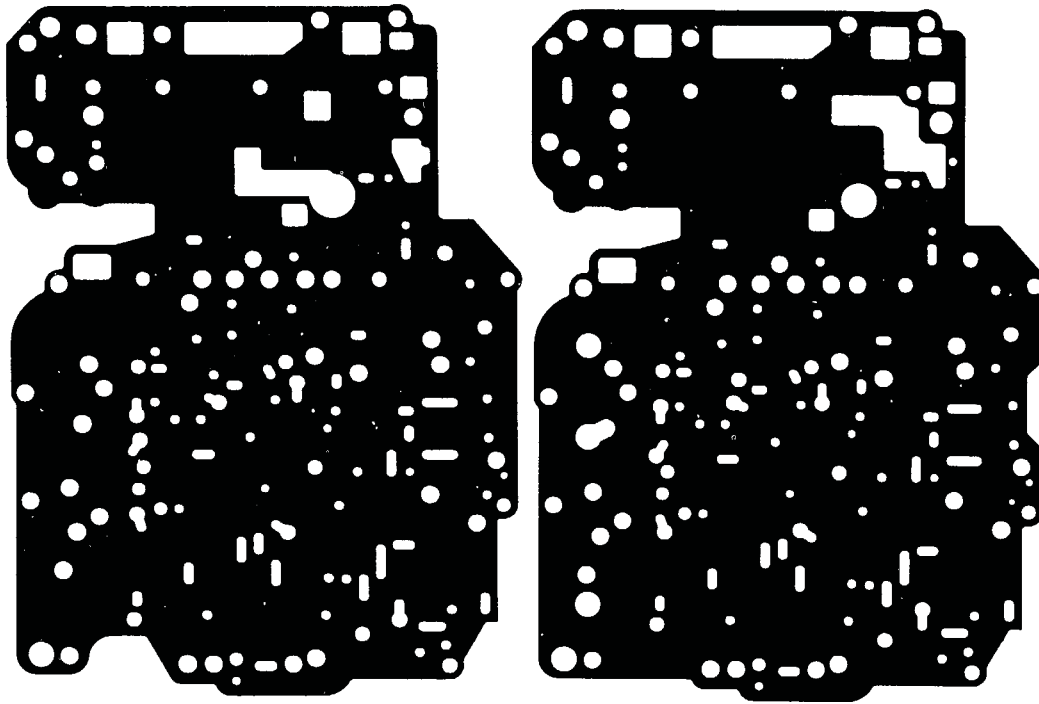

# A40D

## Valve Body

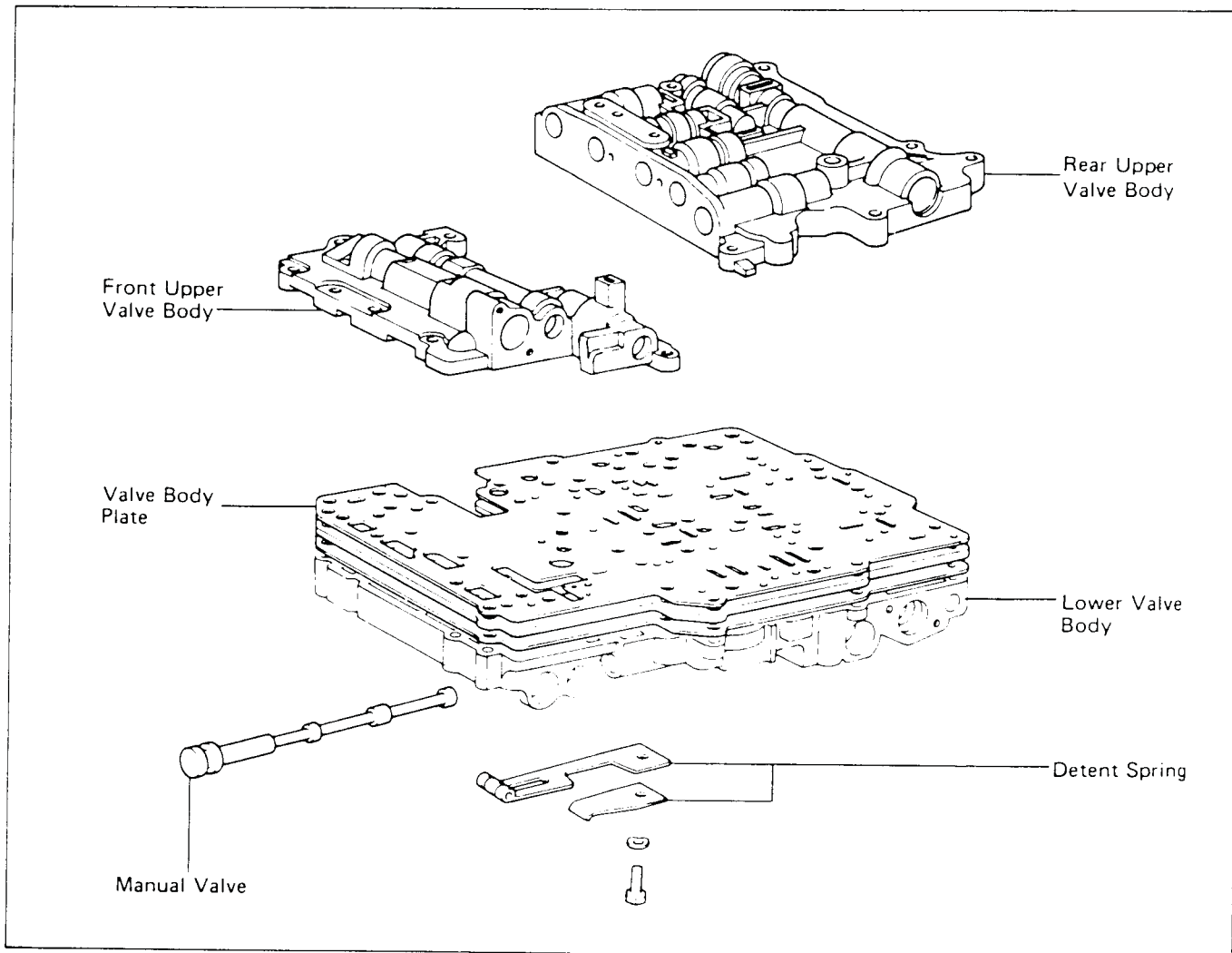



# Technical Service Information (Lower Valve Body)

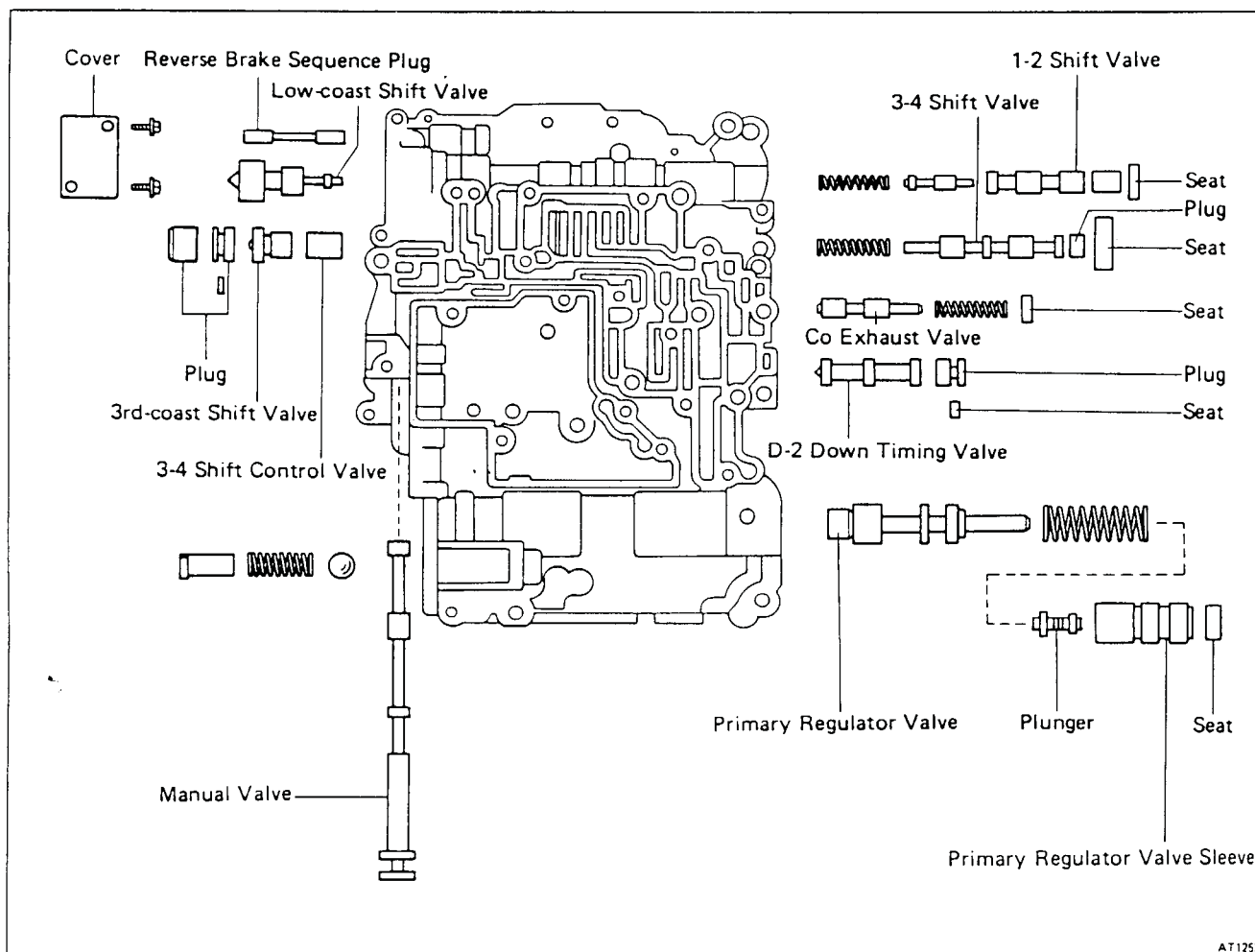

AT1252

## INSPECT VALVE SPRINGS

Check for damage, squareness, rust and distorted coils. Measure the spring free length and replace if less than that shown below.

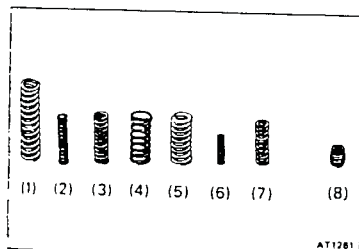

AT1281

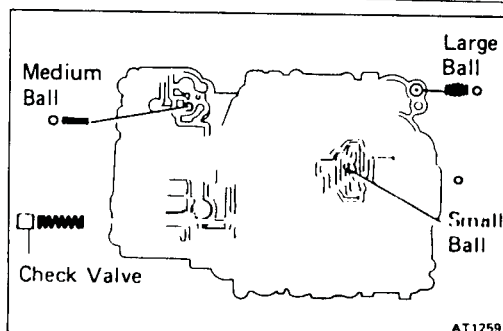

AT1259

	Free length	mm (in.)
(1) Primary regulator valve	60.13	(2.3673)
(2) 1-2 shift valve	34.62	(1.3630)
(3) 3-4 shift valve	35.18	(1.3850)
(4) Check valve (for oil cooler)	33.32	(1.3118)
(5) Pressure relief valve ball	32.14	(1.2654)
(6) Damping ball	20.00	(0.7874)
(7) Overdrive clutch exhaust	31.09	(1.2240)
(8) Cooler return	13.70	(0.5394)

# Technical Service Information (Upper Front Valve Body)

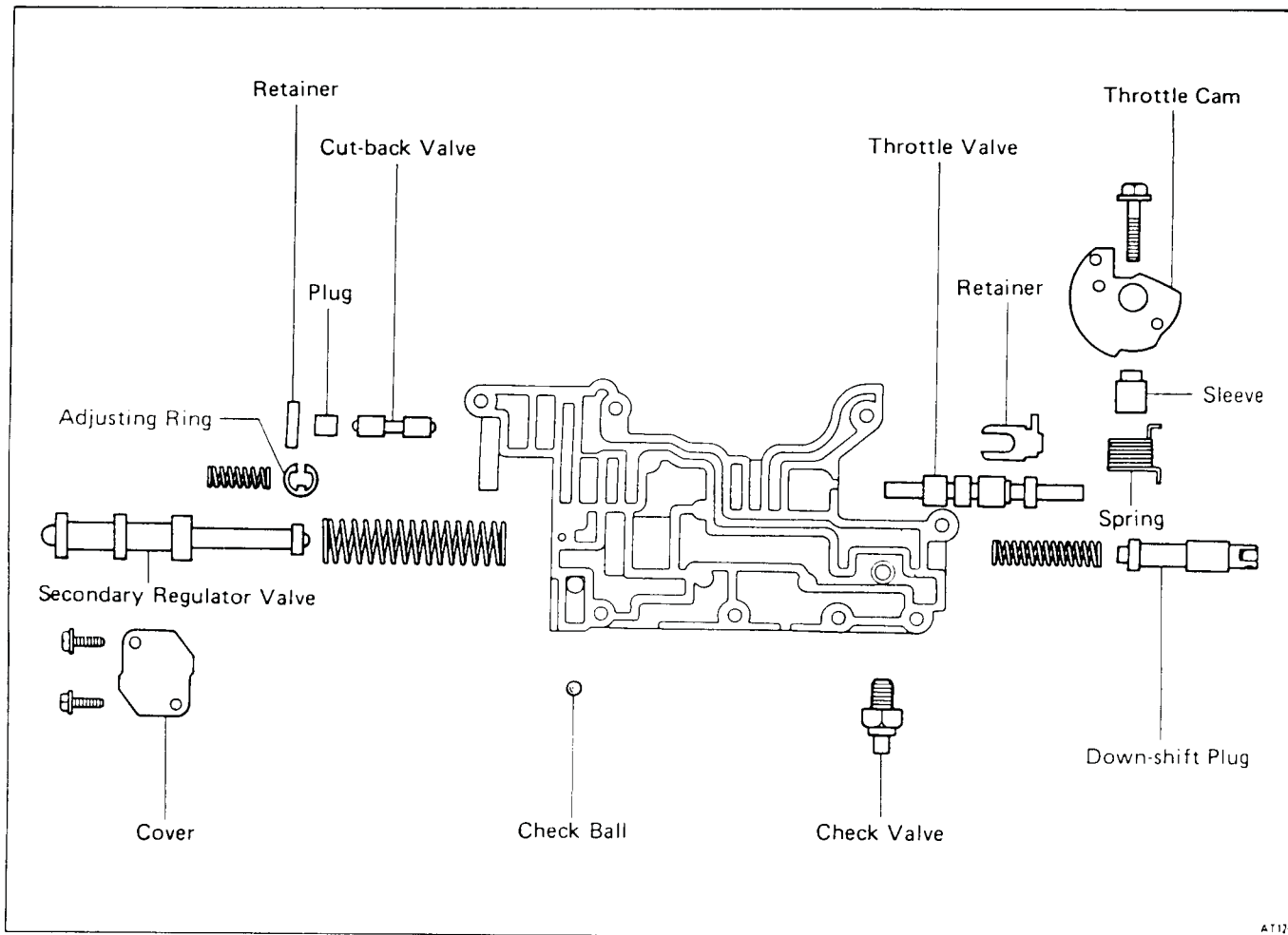

## INSPECT VALVE SPRINGS

Check for damage, squareness, rust and collapsed coils. Measure the spring free length and replace if less than that shown below.

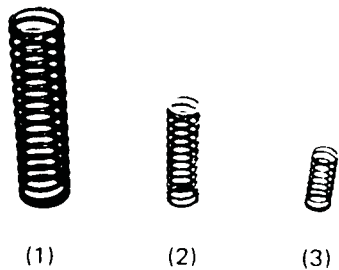

	Free length	mm (in.)
(1) Secondary regulator valve	71.27	(2.8059)
(2) Down-shift plug	39.71	(1.5634)
(3) Throttle valve	21.94	(0.8638)



# Technical Service Information (Upper Rear Valve Body)

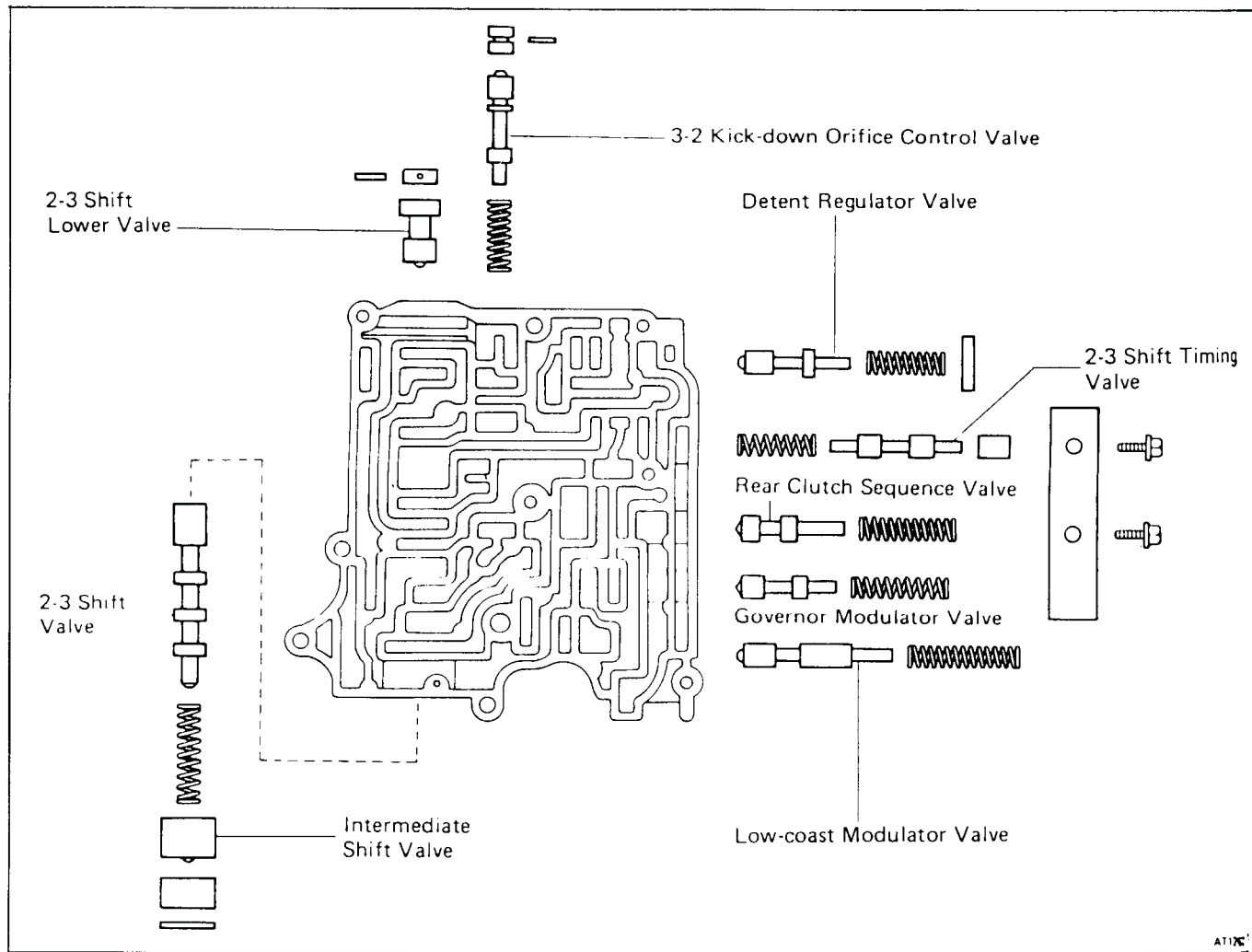

## INSPECT VALVE SPRINGS

Check for damage, squareness, rust and collapsed coils. Measure the spring free length and replace if less than that shown below.

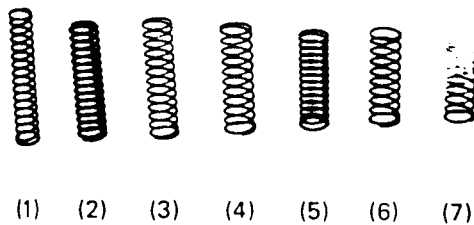

	Free length	mm (in.)
(1) Low-coast modulator valve	42.35	(1.6673)
(2) Rear clutch sequence valve	37.55	(1.4783)
(3) Governor modulator valve	36.07	(1.4201)
(4) 2-3 shift valve	34.09	(1.3421)
(5) Detent regulator valve	30.43	(1.1980)
(6) 2-3 shift timing valve	29.82	(1.1740)
(7) 3-2 kick-down orifice control valve	25.17	(0.9909)



# Technical Service Information

A40D EARLY

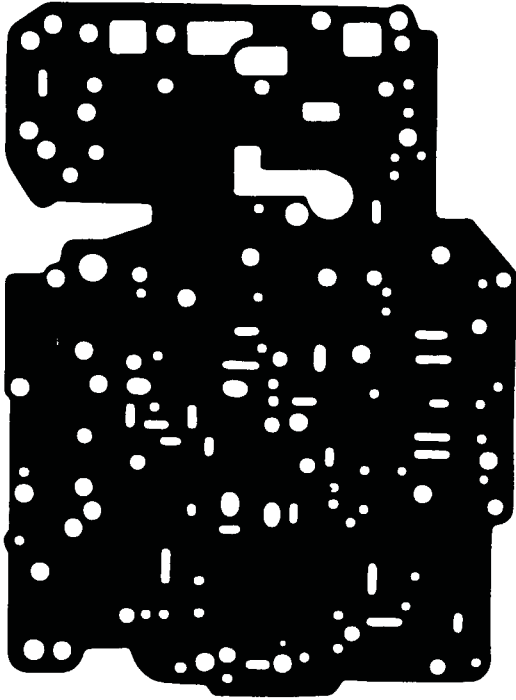

A40D EARLY

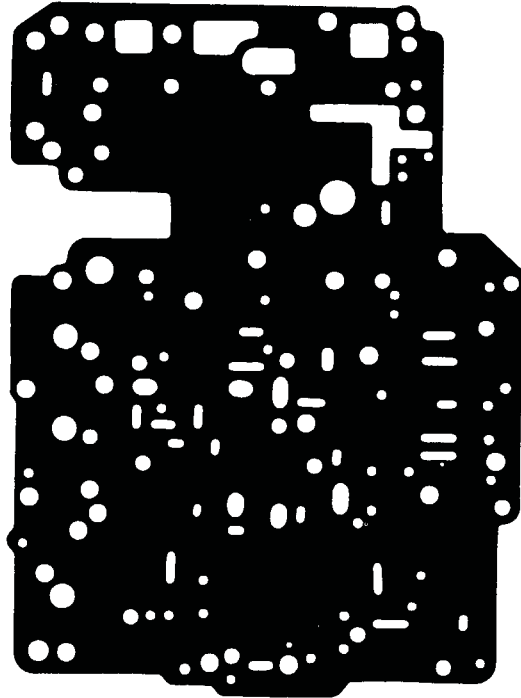

A40D EARLY

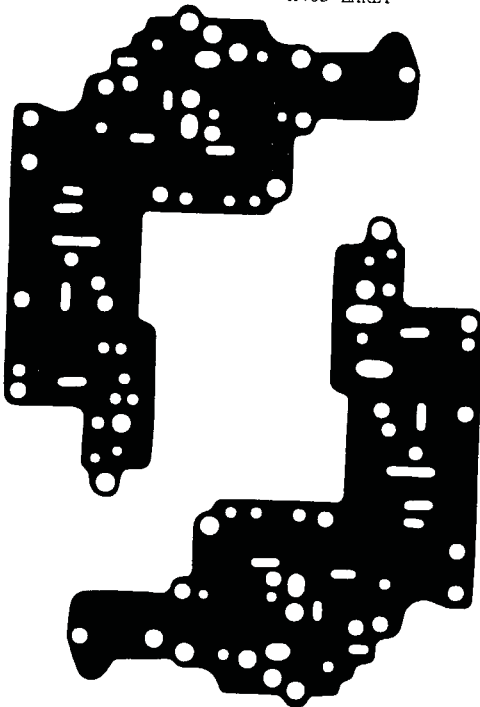

A40D EARLY

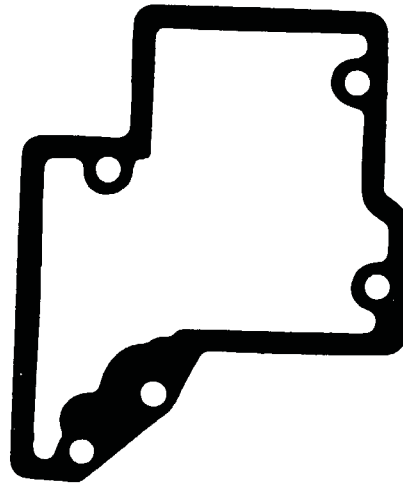

AUTOMATIC TRANSMISSION SERVICE GROUP



# Technical Service Information

A40D LATE 8/81-UP

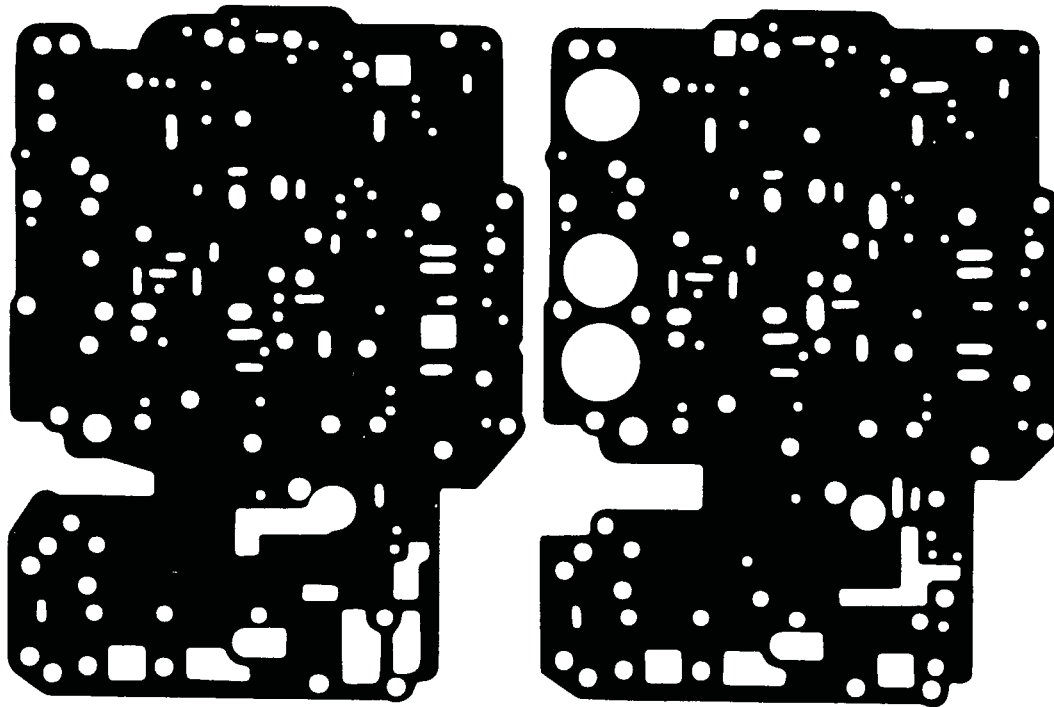

A40D LATE 8/81-UP

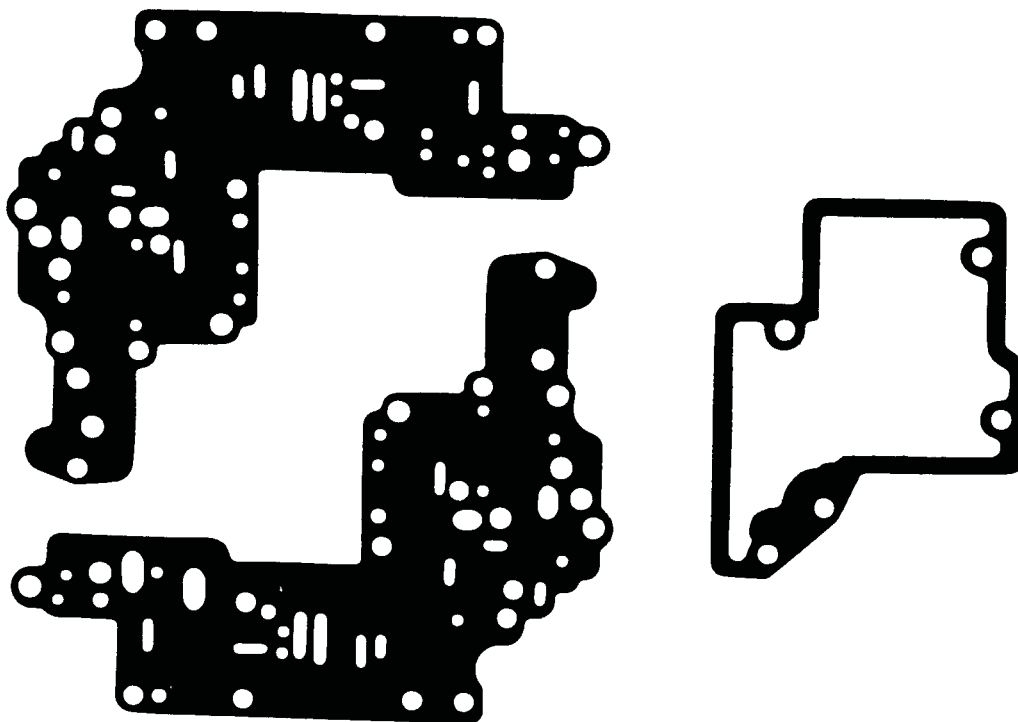

AUTOMATIC TRANSMISSION SERVICE GROUP



# A42D A43D

## Valve Body

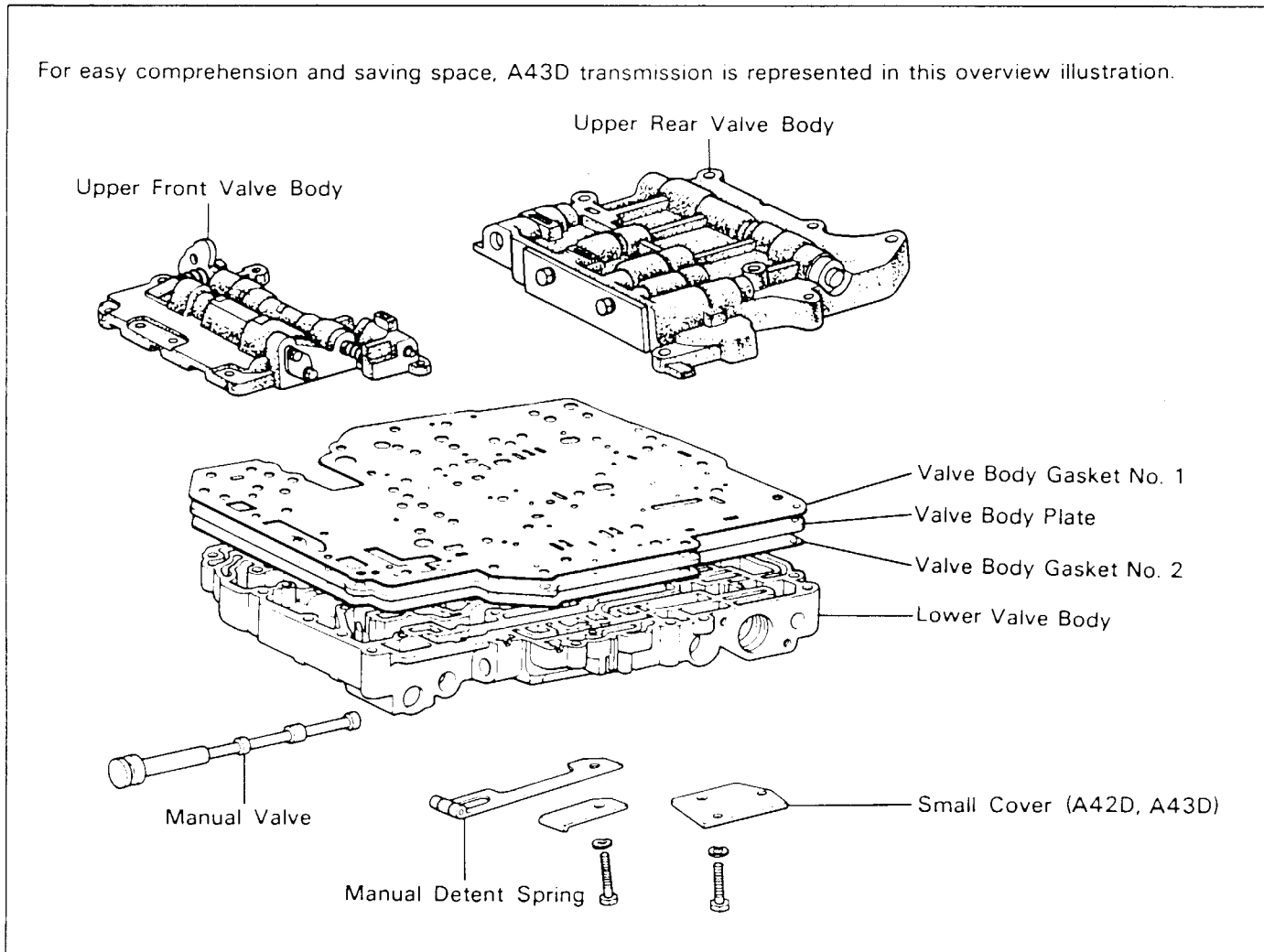



# Technical Service Information (Lower Valve Body)

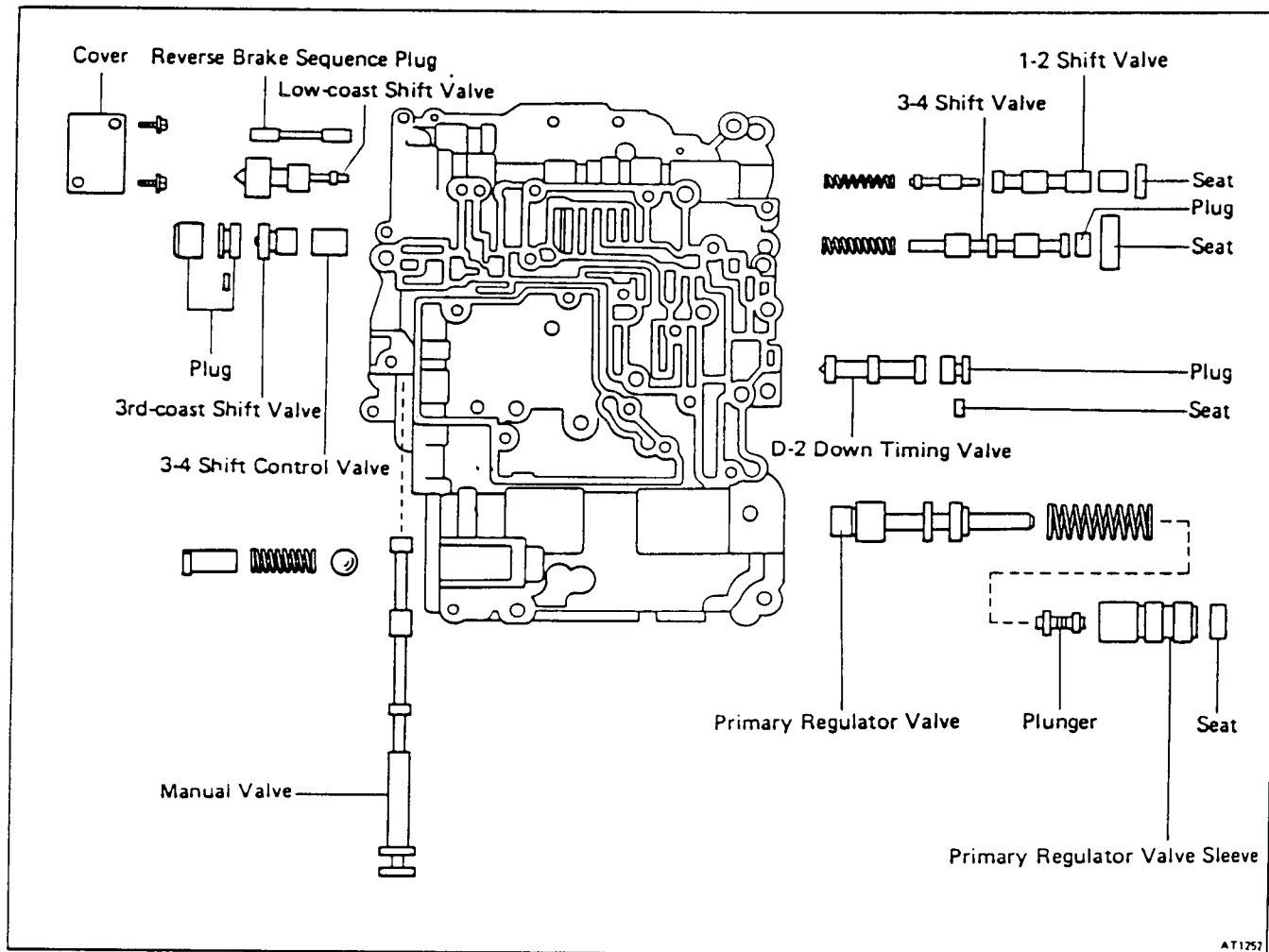

AT1252

## INSPECTION OF LOWER VALVE BODY

### INSPECT VALVE SPRINGS

Check for damage, squareness, rust and distorted coils. Measure the spring free height and replace if less than that shown below.

A42D, A43D

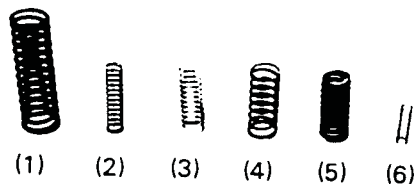

Free height mm (in.)

	A40D	A42D	A43D
(1) Primary regulator valve	73.32 (2.8866)	←	61.20 (2.4094)
(2) 1-2 shift valve	34.62 (1.3630)	←	←
(3) 3-4 shift valve	33.65 (1.3248)	35.18 (1.3850)	33.65 (1.3248)
(4) Check valve (for oil cooler)	33.32 (1.3118)	←	←
(5) Pressure relief valve ball	32.14 (1.2654)	←	←
(6) Damping ball	19.50 (0.7677)	20.00 (0.7874)	←



# Technical Service Information (Upper Rear Valve Body)

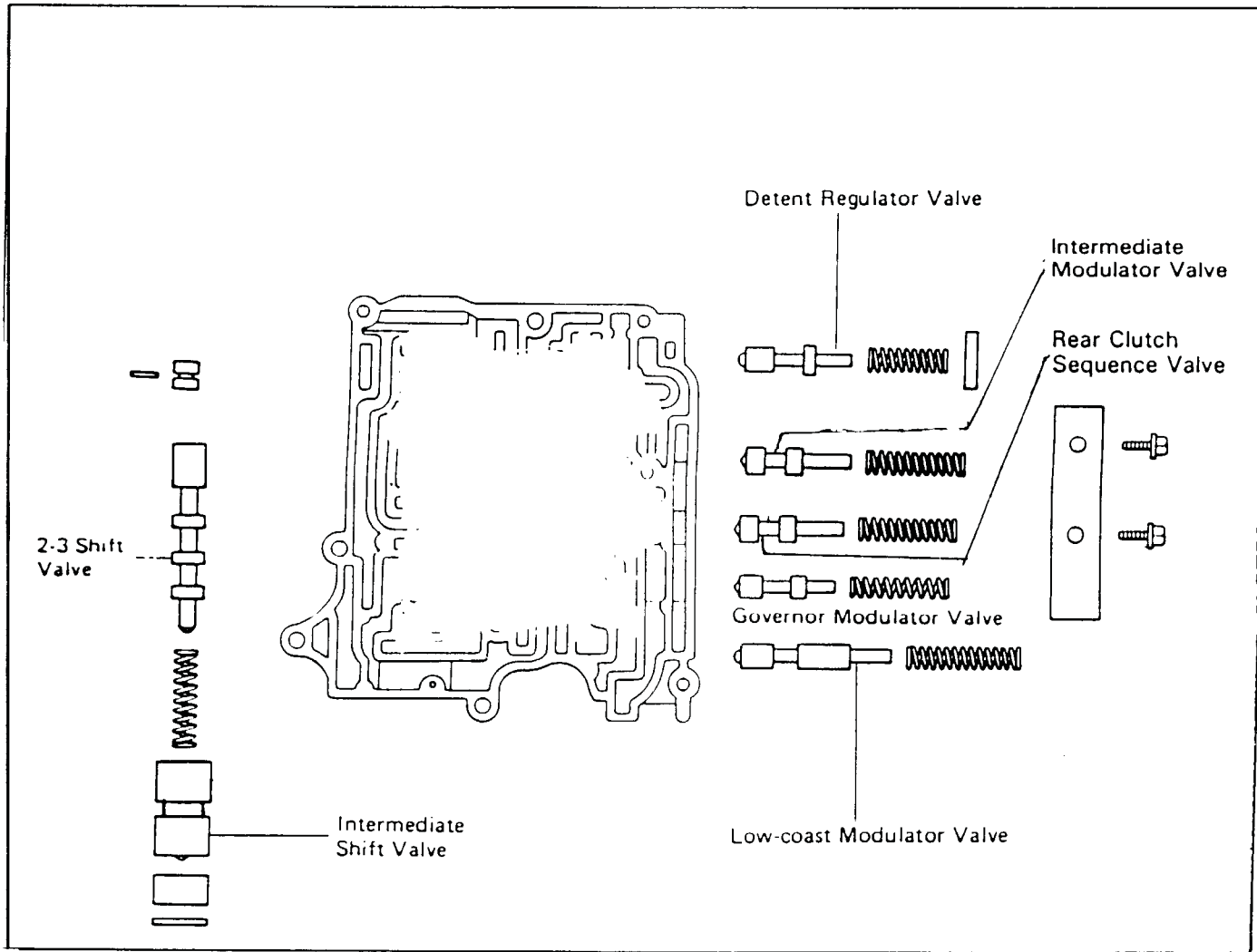

## INSPECT VALVE SPRINGS

Check for damage, squareness, rust and collapsed coils. Measure the spring free height and replace if less than that shown below.

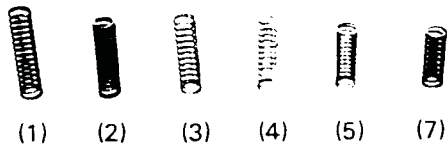

		Free height		
		mm (in.)		
		A40D	A42D	A43D
(1)	Low-coast modulator valve	42.35 (1.6673)	—	—
(2)	Rear clutch sequence valve	37.55 (1.4783)	—	—
(3)	Governor modulator valve	36.07 (1.4201)	—	—
(4)	2-3 shift valve	34.09 (1.3421)	35.10 (1.3819)	—
(5)	Detent regulator valve	30.43 (1.1980)	26.03 (1.0248)	29.93 (1.1783)
(6)	2-3 shift timing valve	29.82 (1.1740)		
(7)	Intermediate modulator valve		25.60 (1.0079)	27.26 (1.0732)

# Technical Service Information (Upper Front Valve Body)

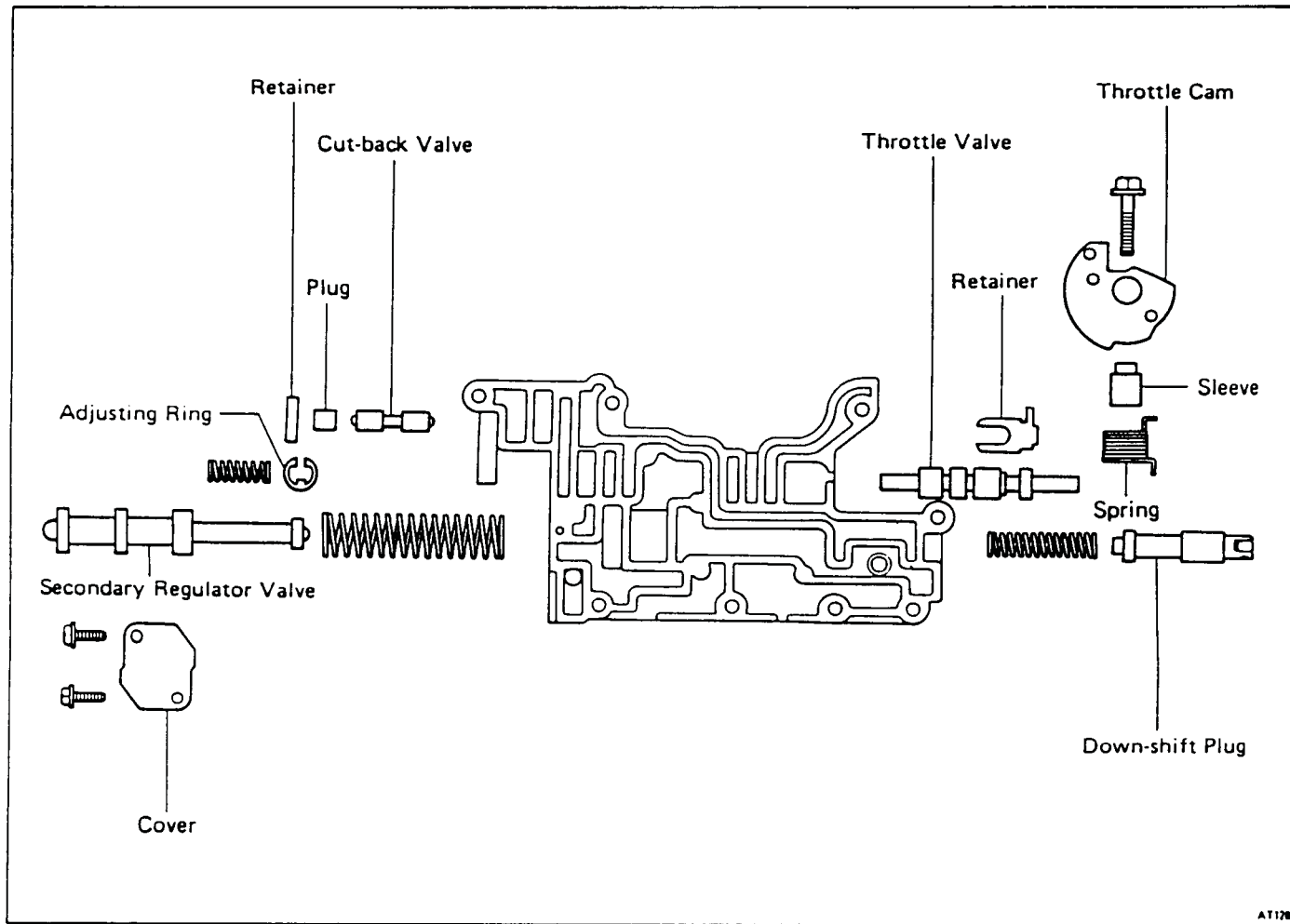

## INSPECT VALVE SPRINGS

Check for damage, squareness, rust and collapsed coils. Measure the spring free length and replace if less than that shown below.



(1)



(2)



(3)

	A40D	A42D	A43D
(1) Secondary regulator valve	71.27 (2.8059)	—	—
(2) Down-shift plug	43.00 (1.6929)	40.24 (1.5842)	39.71 (1.5634)
(3) Throttle valve	21.94 (0.8638)	19.24 (0.7575)	—



# Technical Service Information

A42D, A43D, -AW70, AW71

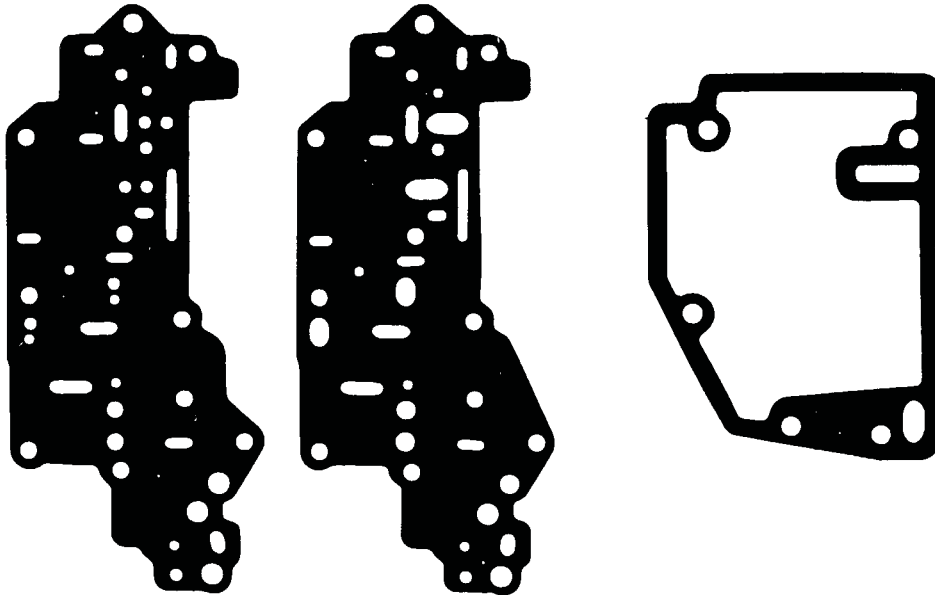
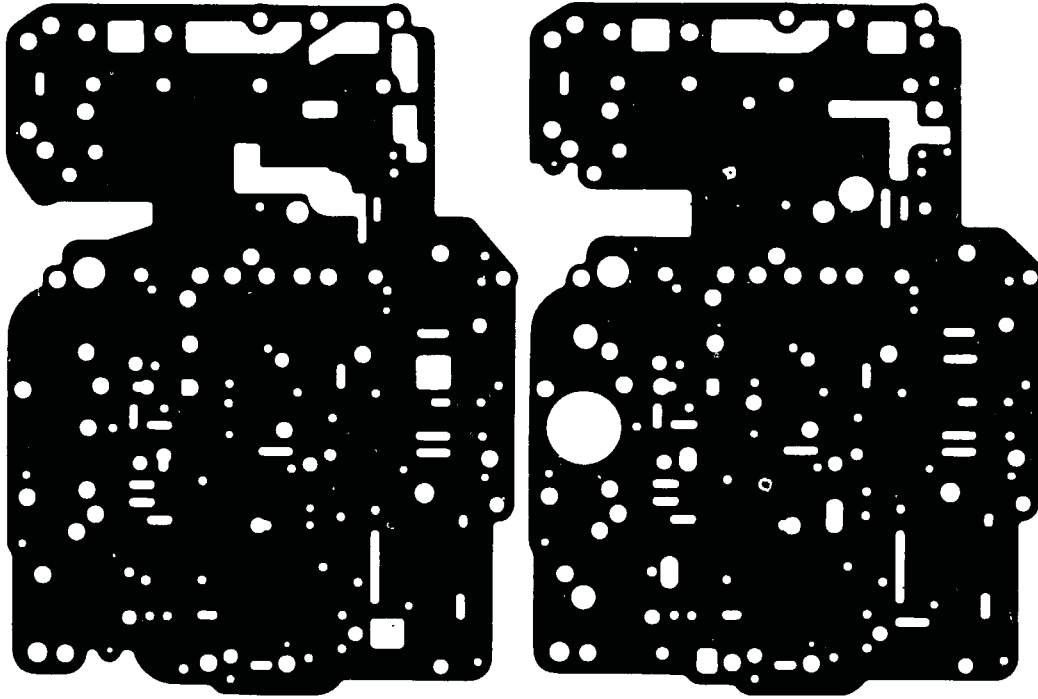

AUTOMATIC TRANSMISSION SERVICE GROUP





# A43DL A44DL

## Valve Body

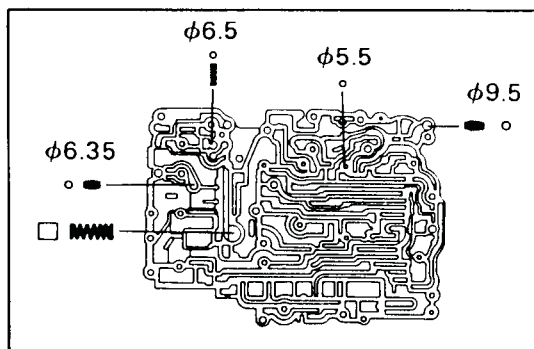
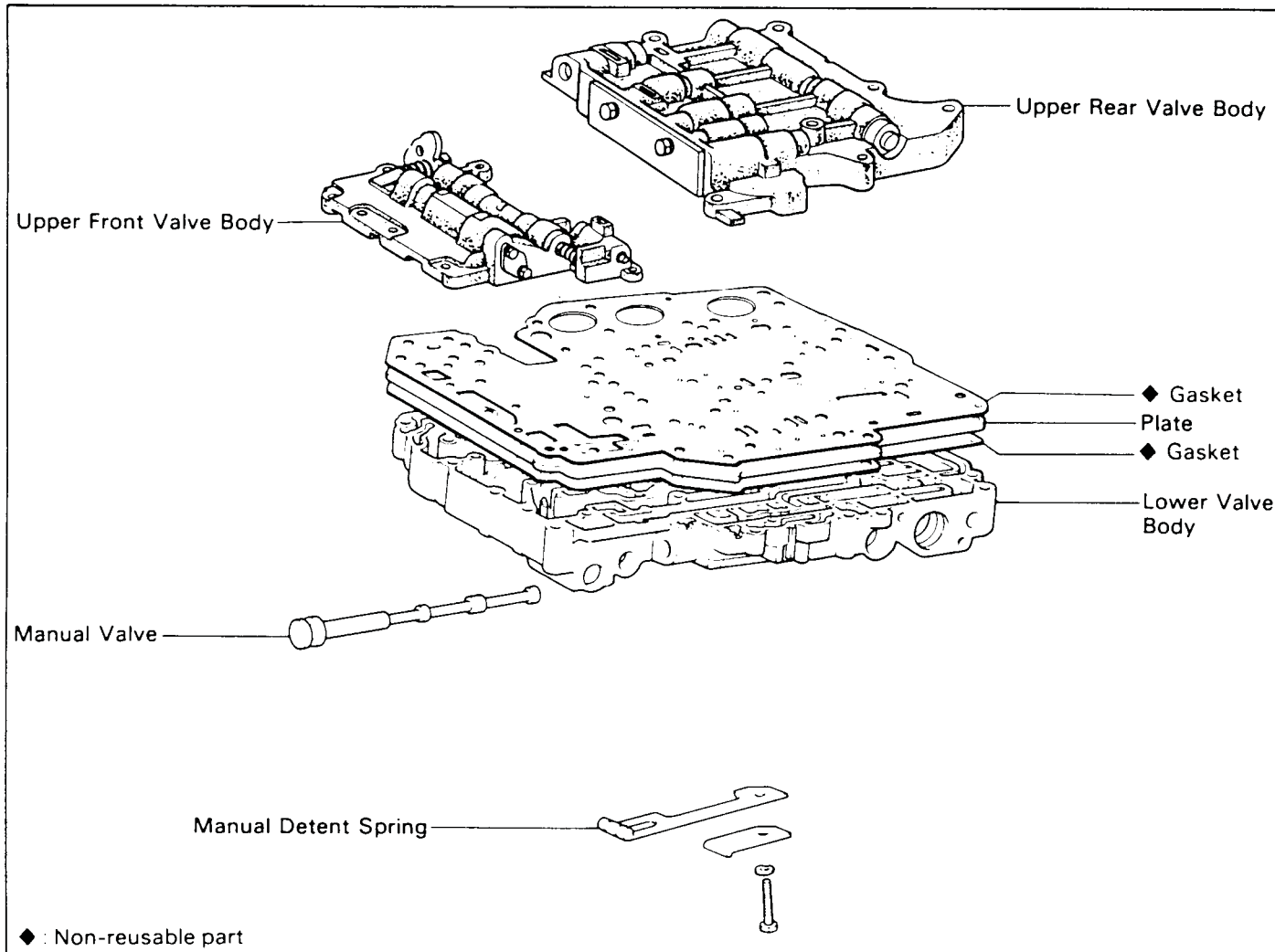



# Technical Service Information

## (Lower Valve Body)

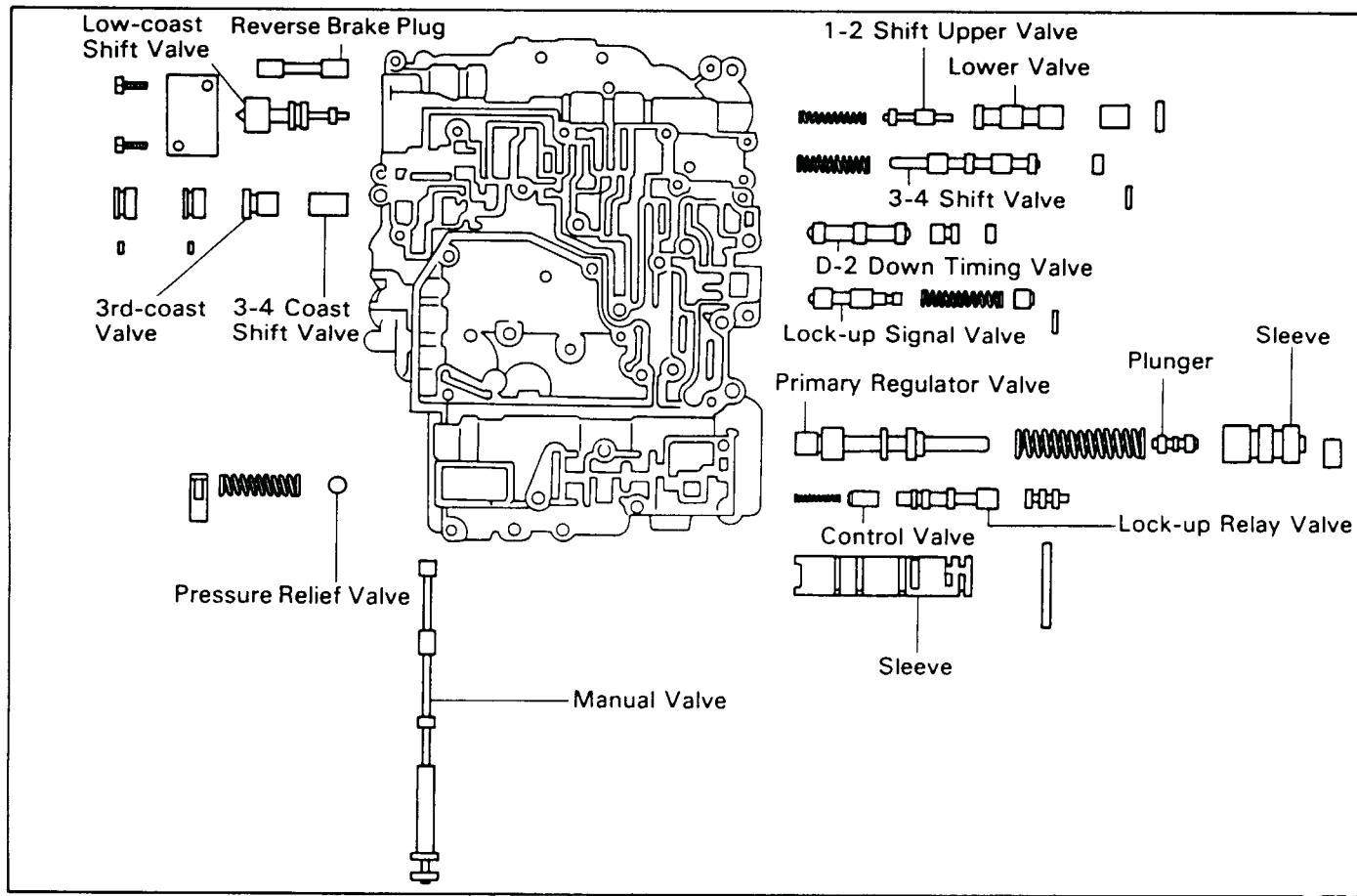

### INSPECT VALVE SPRINGS

Check for damage, squareness, rust and distorted coils. Measure the spring free height and replace it if less than that shown below.

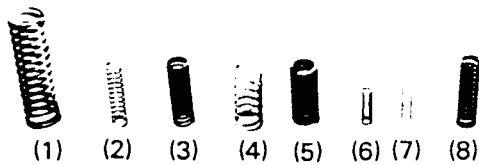

	Free length mm (in.)	Color
(1) Primary regulator valve	61.20 (2.4094)	White
(2) 1-2 shift valve	34.62 (1.3630)	None
(3) 3-4 shift valve	36.28 (1.4283)	Red
(4) Oil cooler by-pass valve	33.32 (1.3118)	Yellow
(5) Pressure relief valve	32.14 (1.2654)	None
(6) Damping check ball	20.00 (0.7874)	None
(7) Lock-up relay valve	18.50 (0.7283)	White
(8) Lock-up signal valve	38.60 (1.5197)	Light Blue
Converter charge ball	9.70 (0.3835)	None
Coller return ball	13.70 (0.5394)	None

## (Upper Front Valve Body)

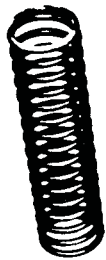
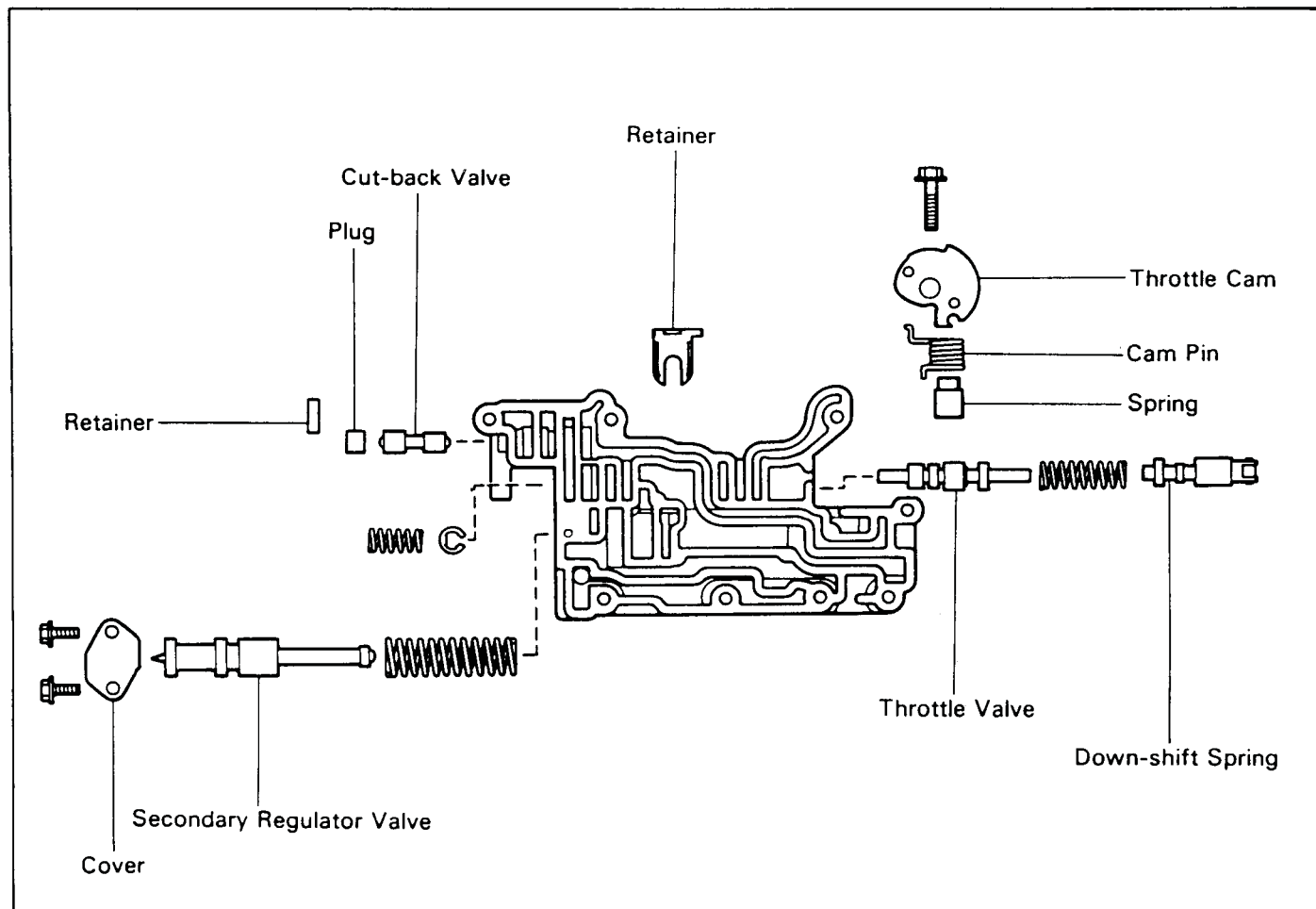

(1)



(2)



(3)

### INSPECT VALVE SPRINGS

Check for damage, squareness, rust and collapsed coils. Measure the spring free height and replace if less than that shown below.

	Free length mm (in.)	Color
(1) Secondary regulator valve	71.27 (2.8059)	Green
(2) Down-shift plug	39.76 (1.5654)	Purple
(3) Throttle valve	21.94 (0.8638)	None



# Technical Service Information (Upper Rear Valve Body)

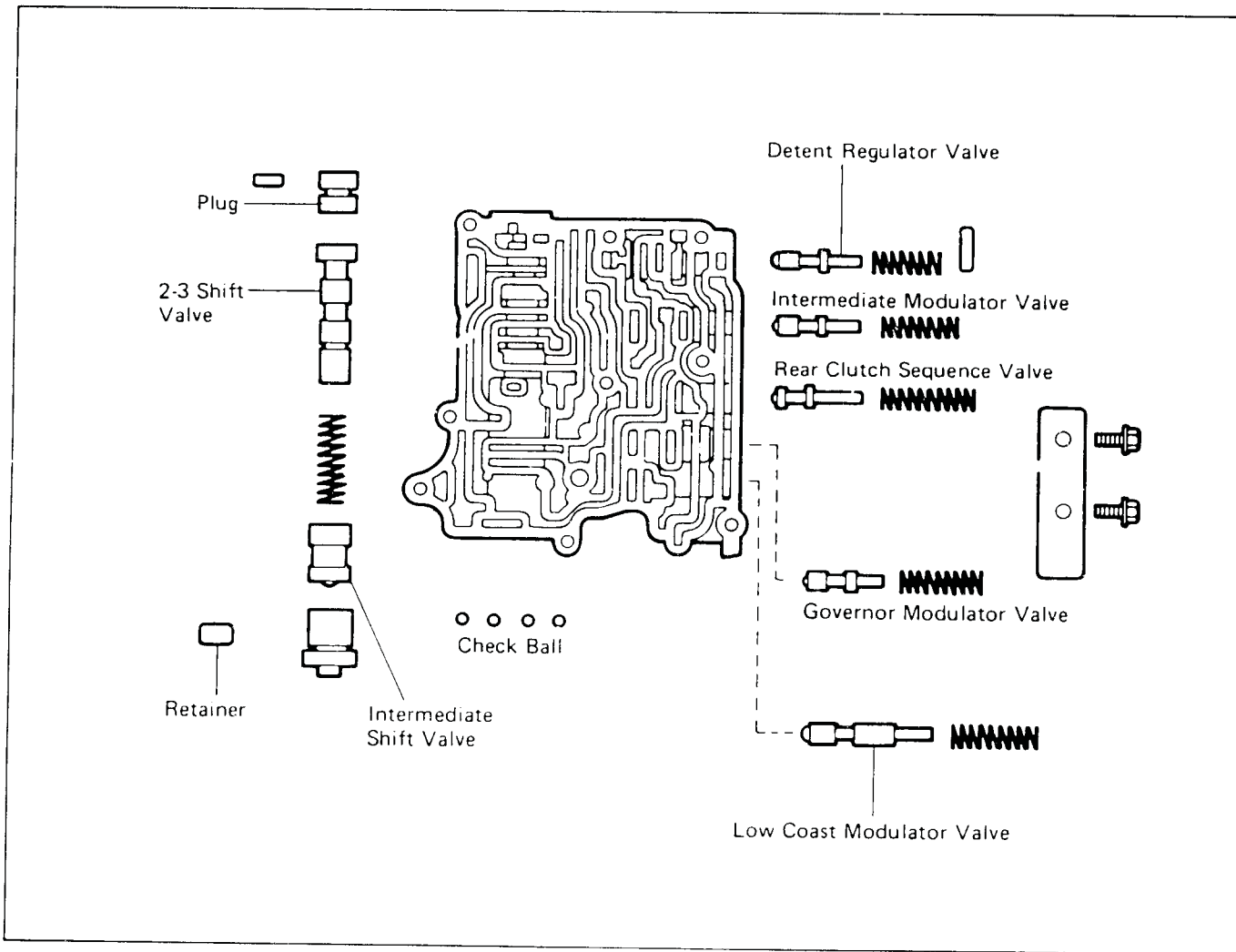

## INSPECTION OF UPPER REAR VALVE BODY

### INSPECT VALVE SPRINGS

Check for damage, squareness, rust and collapsed coils. Measure the spring free height and replace it if less than that shown below.

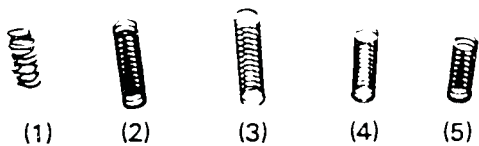

	Free length mm (in.)	Color
(1) Low-coast modulator valve	42.35 (1.6673)	None
(2) Rear clutch sequence valve	37.55 (1.4783)	Red
(3) 2-3 shift valve	35.10 (1.3819)	White
(4) Detent regulator valve	32.08 (1.2630)	None
(5) Intermediate modulator valve	27.26 (1.0732)	Green



# Technical Service Information

TOYOTA A43DL

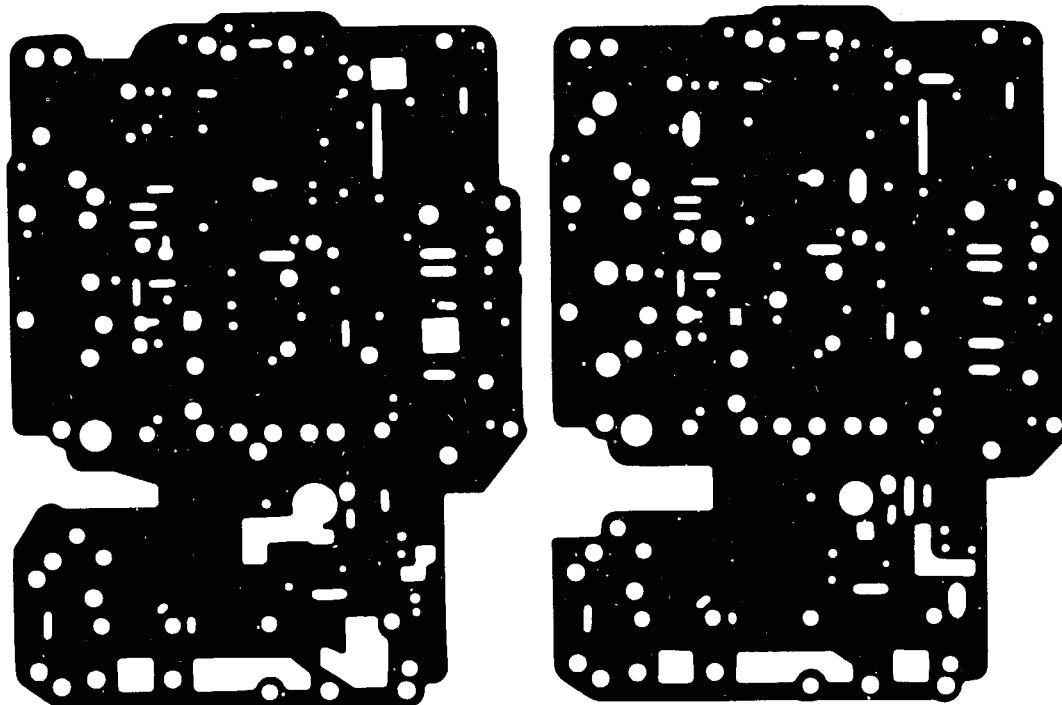

A44DL  
LOWER

A44DL  
UPPER

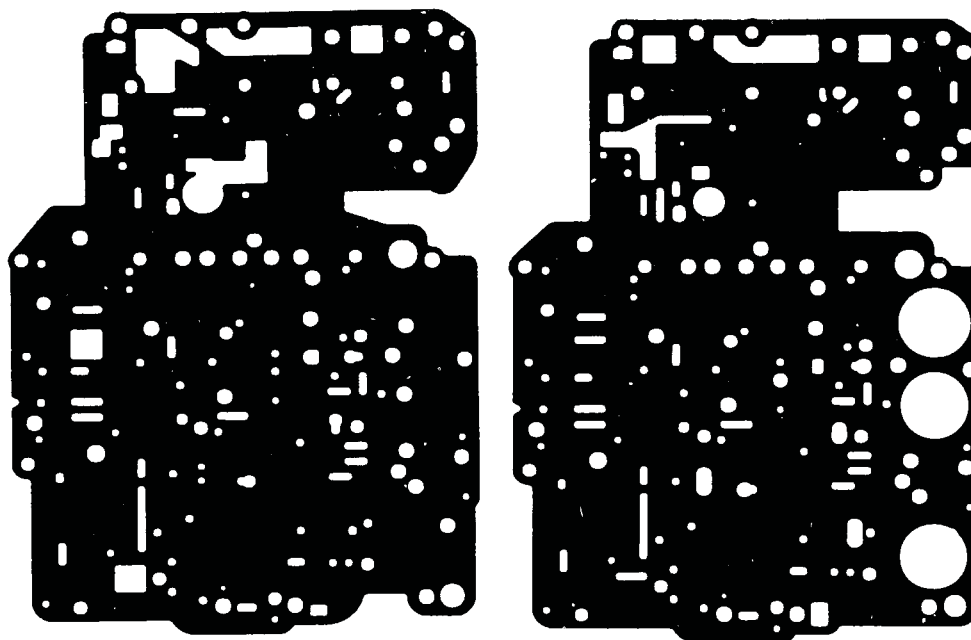

AUTOMATIC TRANSMISSION SERVICE GROUP



# Technical Service Information

TOYOTA A44DL/A43DL

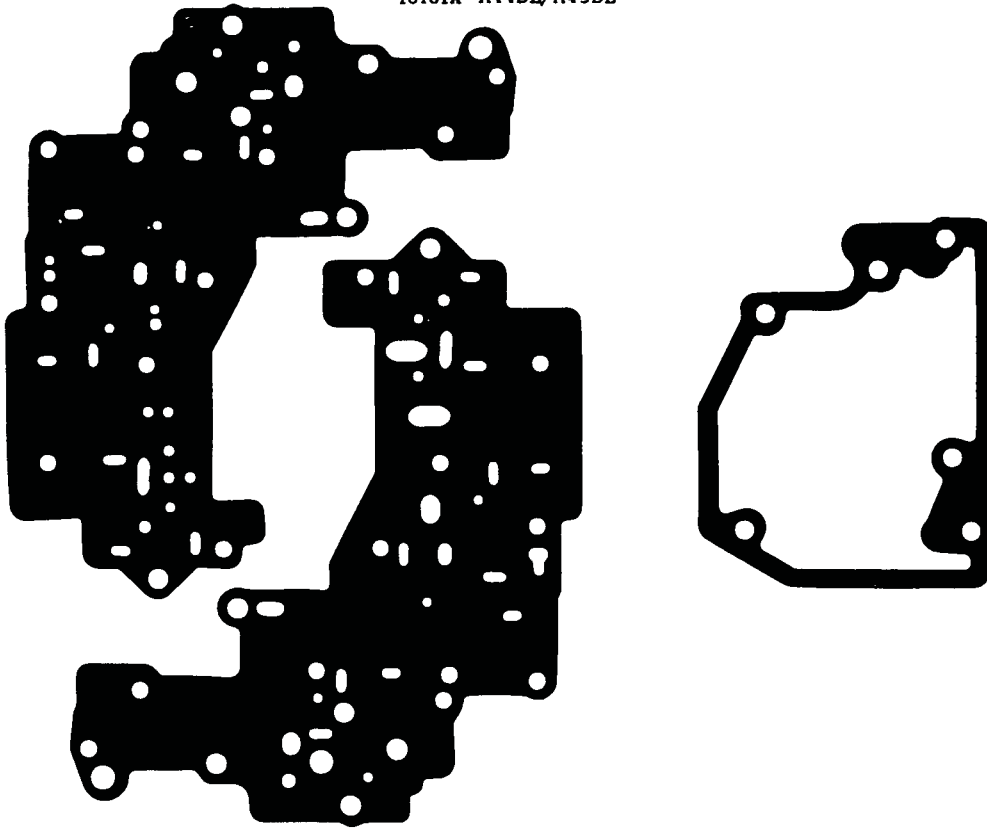



# A43DE

## Valve Body

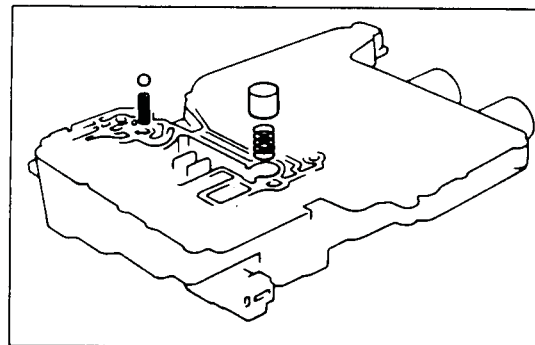
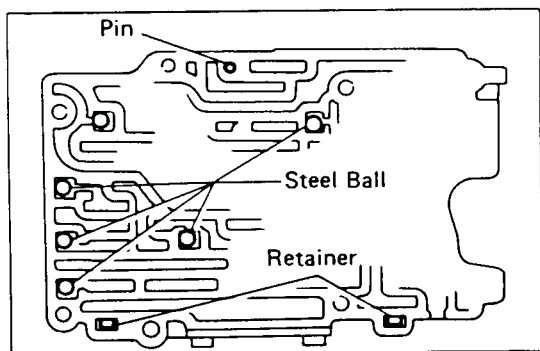
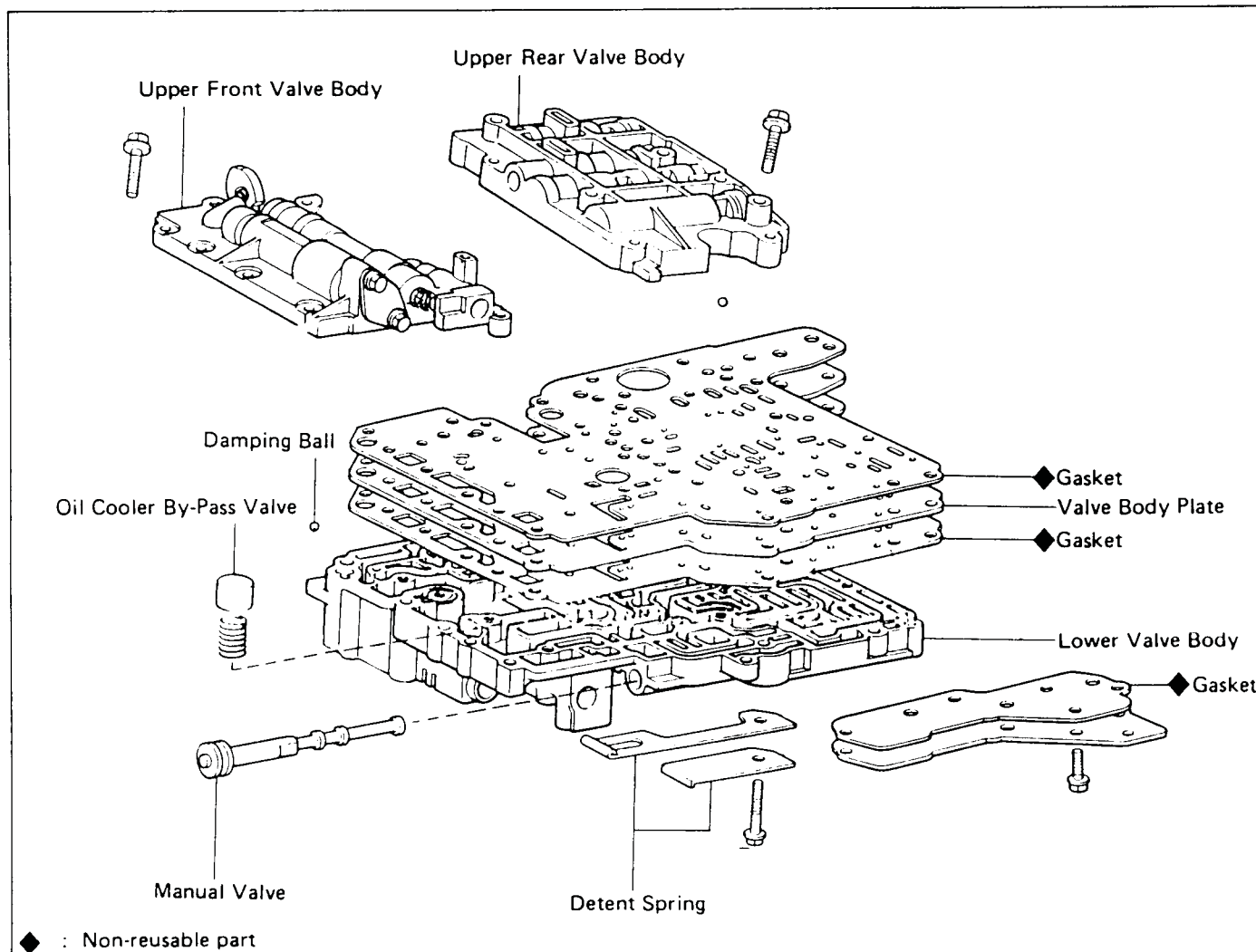

AUTOMATIC TRANSMISSION SERVICE GROUP



# Technical Service Information

## (Lower Valve Body)

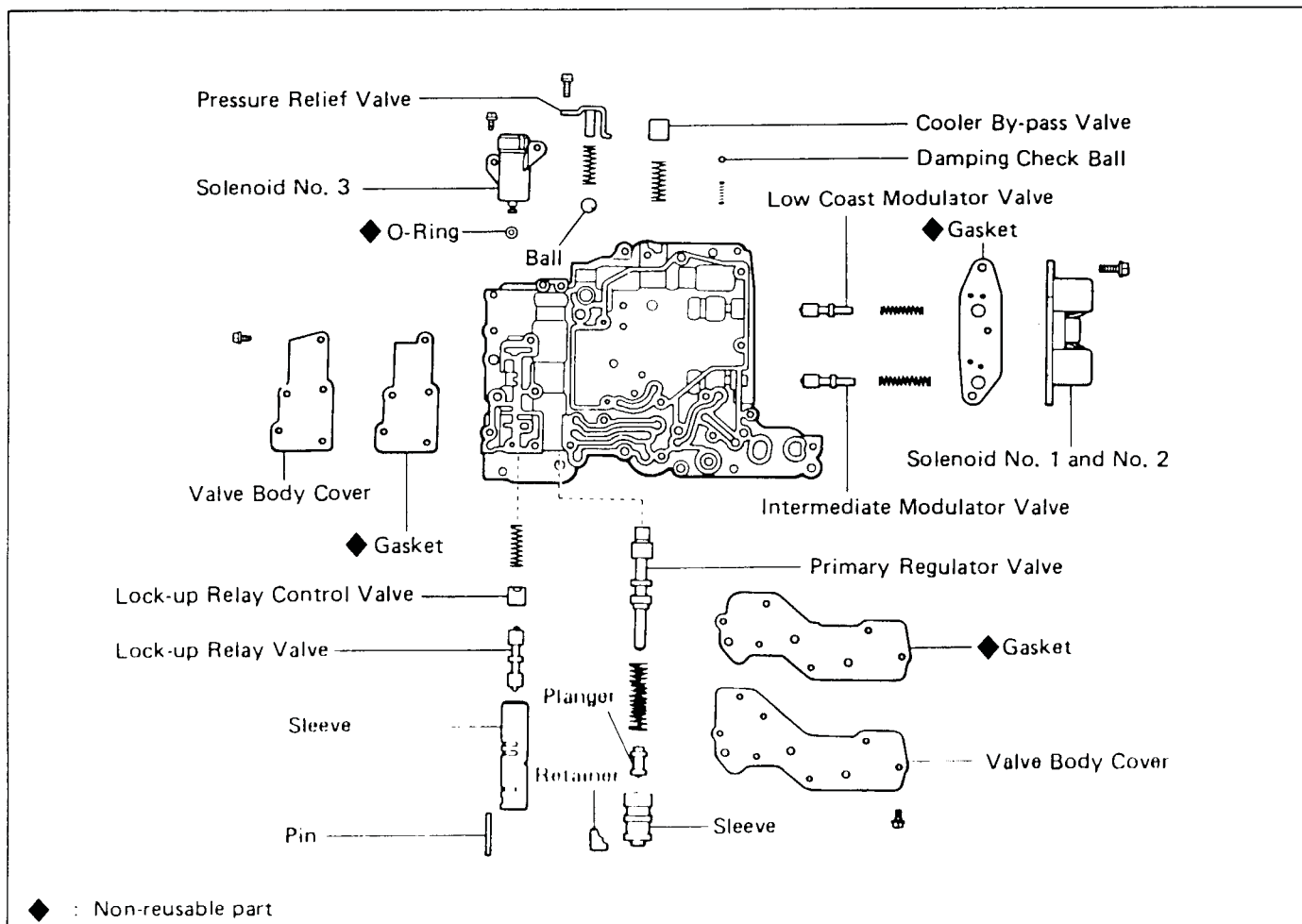

### INSPECTION OF LOWER VALVE BODY

#### INSPECT VALVE SPRINGS

Check for damage, squareness, rust and distorted coils. Measure the spring free height and replace if less than that shown below.

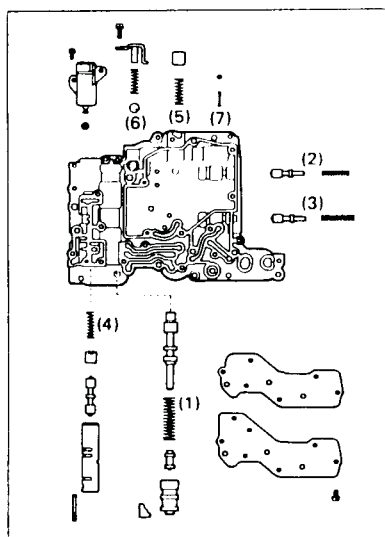

Spring	Free height	mm (in.)	Color
(1) Primary regulator valve	56.30	(2.2165)	Blue
(2) Low coast modulator valve	42.35	(1.6673)	None
(3) Intermediate modulator valve	35.43	(1.3949)	Red
(4) Lock-up relay control valve	34.60	(1.3622)	Yellow
(5) Oil cooler by-pass valve	33.32	(1.3118)	Yellow
(6) Pressure relief valve	32.14	(1.2654)	None
(7) Damping check ball	20.00	(0.7874)	None





# Technical Service Information (Upper Front Valve Body)

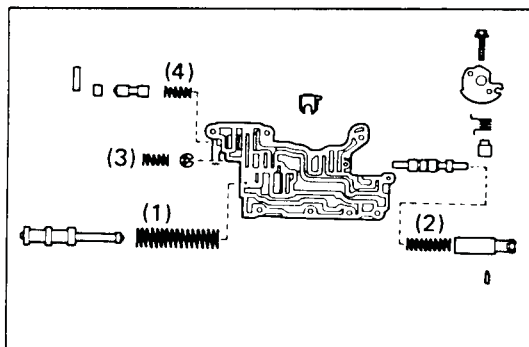
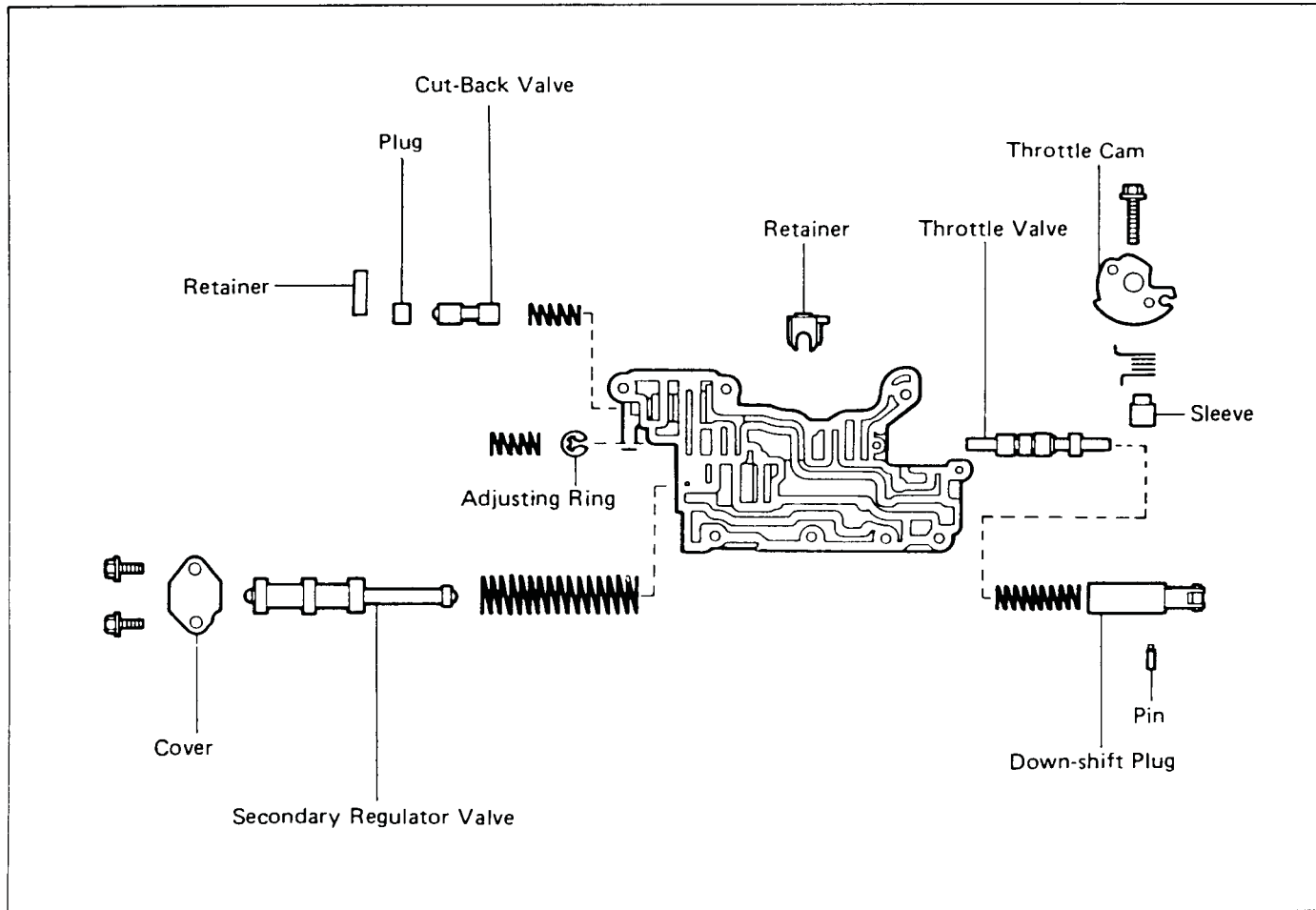

## INSPECTION OF UPPER FRONT VALVE BODY

### INSPECT VALVE SPRINGS

Check for damage, squareness, rust and collapsed coils. Measure the spring free height and replace if less than that shown below.

Spring	Free height	mm (in.)	Color
(1) Secondary regulator valve	71.27	(2.8059)	Green
(2) Down-shift plug	39.55	(1.5571)	Green
(3) Throttle valve	19.24	(0.7575)	None
(4) Cut-back valve	23.00	(0.9055)	Green

## (Upper Rear Valve Body)

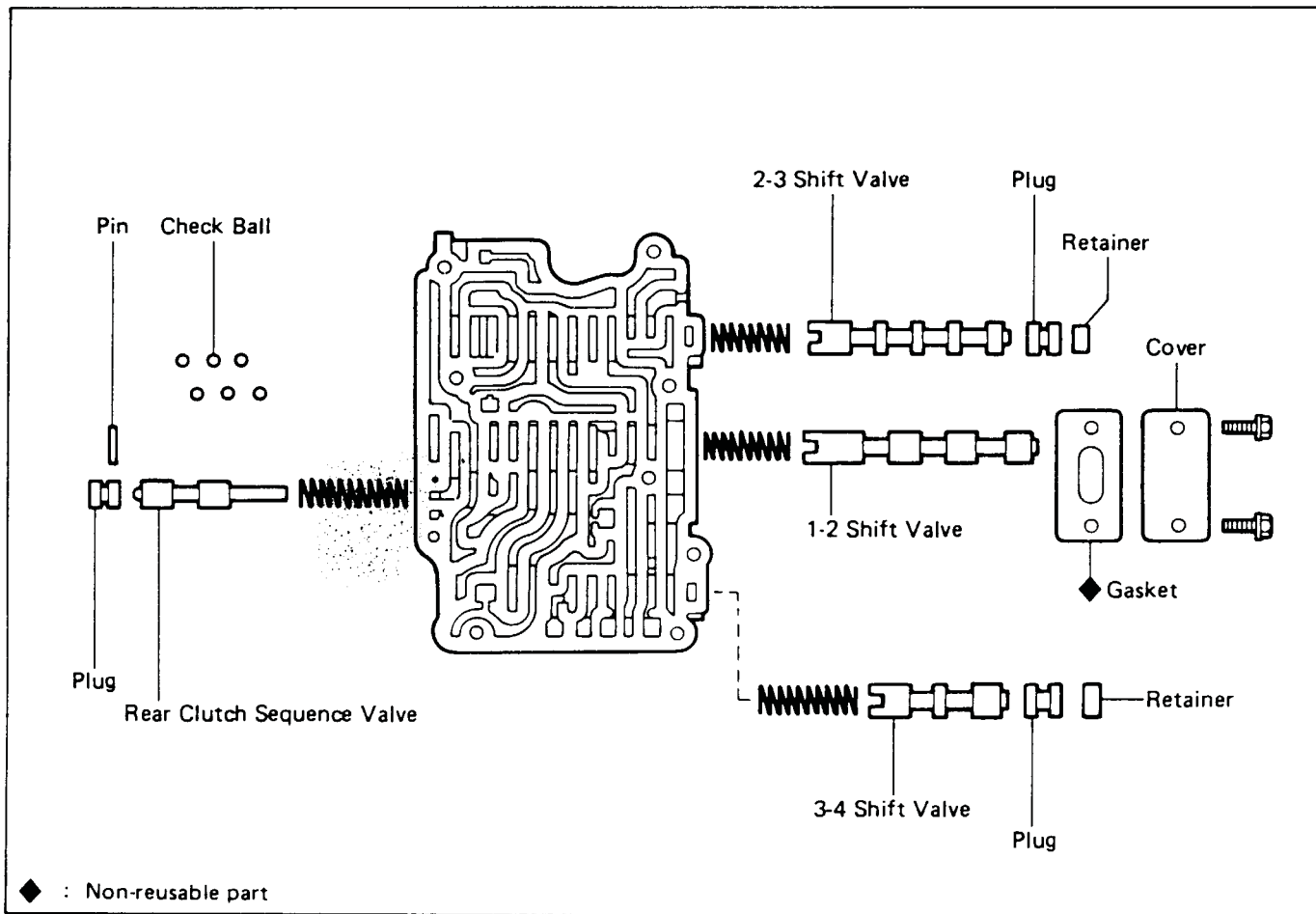

### INSPECTION OF UPPER REAR VALVE BODY

#### INSPECT VALVE SPRINGS

Check for damage, squareness, rust and collapsed coils. Measure the spring free height and replace if less than that shown below.

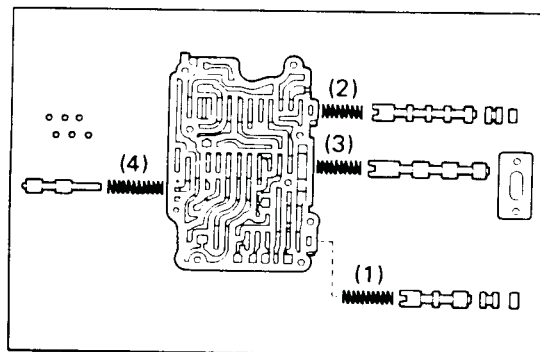

Spring	Free height mm (in.)	Color
(1) 3-4 Shift valve	29.15 (1.1476)	Blue
(2) 2-3 Shift valve	29.15 (1.1476)	Blue
(3) 1-2 Shift valve	29.15 (1.1476)	Blue
(4) Rear clutch sequence valve	37.55 (1.4783)	None



# Technical Service Information

A43DE  
A46DE

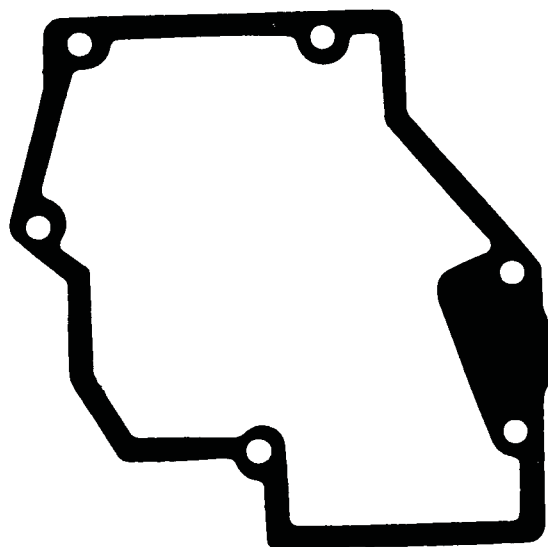
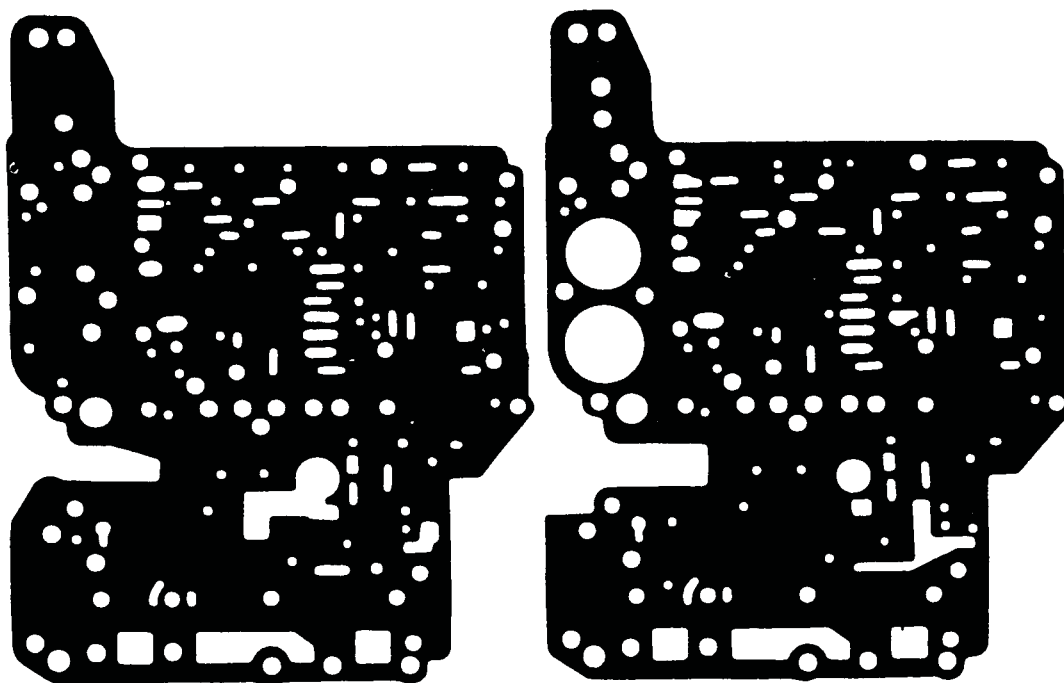

Technical Service Information



# Technical Service Information

TITLE 1982 AUTOMATIC TRANSMISSION CHANGES: A40, A40D, A43D, A43DL

To improve performance of the automatic transmission, the following modifications have been carried out. These modifications affect all 1982 models equipped with automatic transmission, except Tercel.

## AUTOMATIC TRANSMISSION TYPE AND MODEL APPLICATION

A40: TE  
A40D: TE, RA, RT  
A43D: MX, RN  
A43DL: MA

## PRODUCTION EFFECTIVE:

From Transmission No.	A40	1HA-34059	(August, 1981)
	A40D	1HB-03287	(August, 1981)
	*A43D	1HF-01983	(August, 1981)
	**A43D	1KF-05800	(October, 1981)
	**A43D	1KF-50141	(October, 1981)
	A43DL	1HH-00185	(August, 1981)

\*Except thrust bearing modification.

\*\*Modification of thrust bearing only.

## MODIFIED PORTION

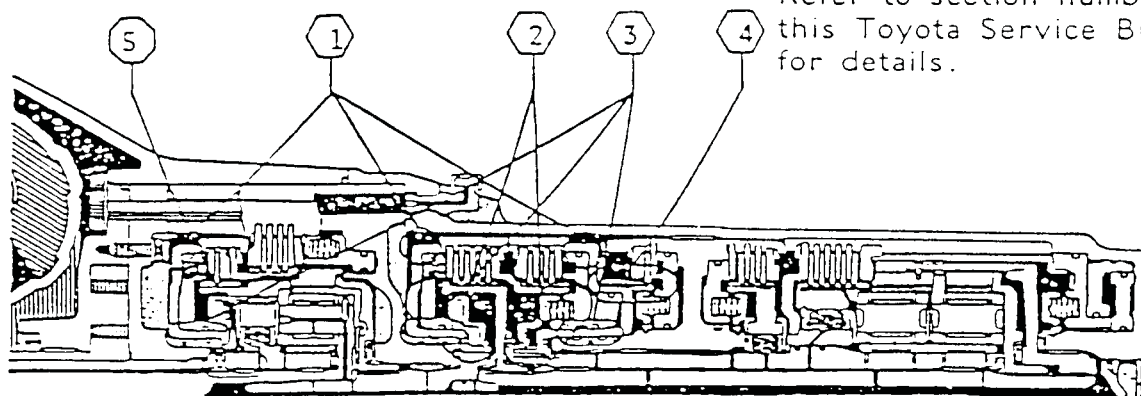

Refer to section numbers in this Toyota Service Bulletin for details.

AUTOMATIC TRANSMISSION SERVICE GROUP



# Technical Service Information

TITLE 1982 AUTOMATIC TRANSMISSION CHANGES A40, A40D, A43D, A43DL

## 1. Clutch Piston Outer "O" Ring

Transmission Type: A40, A40D, A43D and A43DL

Effective Date: August, 1981

Description: To improve durability of the "O" ring for the overdrive clutch (C0), front clutch (C1), and rear clutch (C2), the "O" ring cross-sectional diameter has been increased.

Consequently, the "O" ring groove of each clutch piston has been changed in width and diameter.

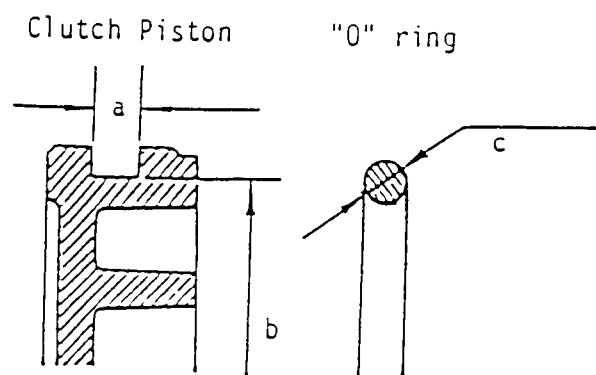

	<u>Previous</u>	<u>New</u>
a. Piston groove width	3.0mm	3.5mm
b. Piston groove diameter	122.95mm	122.25mm
c. "O" ring cross-sectional diameter	2.62mm	3.10mm

Remarks: The front clutch (C1) for A43D and A43DL has previously been modified (March, 1981).

## 2. Clutch Piston Return Spring

Transmission Type: A40

Effective Date: August, 1981

Description: To improve return action of the clutch piston, the return spring for front clutch (C1) and rear clutch (C2) has been changed from a single spring type to a multiple spring type.



# Technical Service Information

TITLE 1982 AUTOMATIC TRANSMISSION CHANGES A40, A40D, A43D, A43DL

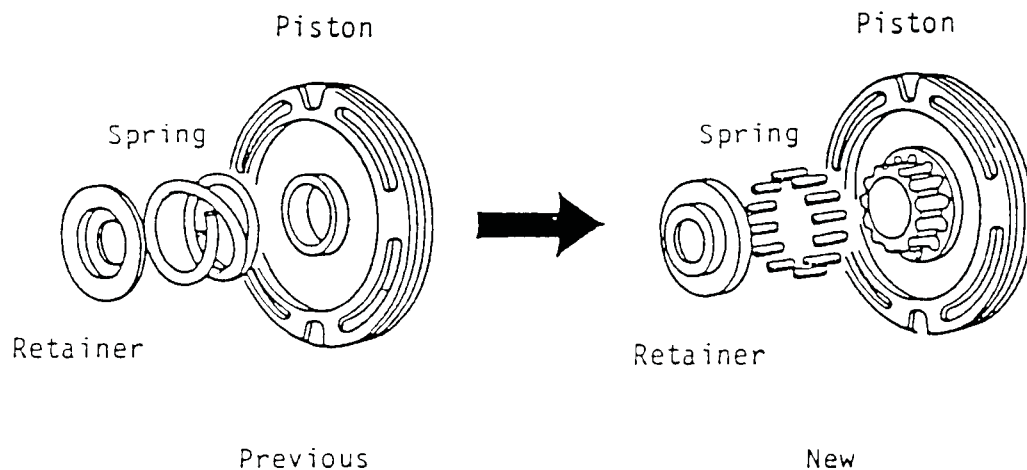

### 3. Clutch Cylinder Oil Seal Ring Portion

Transmission Type: A40, A40D, A43D and A43DL

Effective Date: August, 1981

Description: To improve performance of the oil seal ring of clutch cylinder for the overdrive clutch (C0), front clutch (C1) and rear clutch (C2), the cylinder bore, oil seal ring and ring groove diameters have been increased.

#### (1) Overdrive clutch (C0) oil pump cover

Transmission Type: A40D, A43D and A43DL

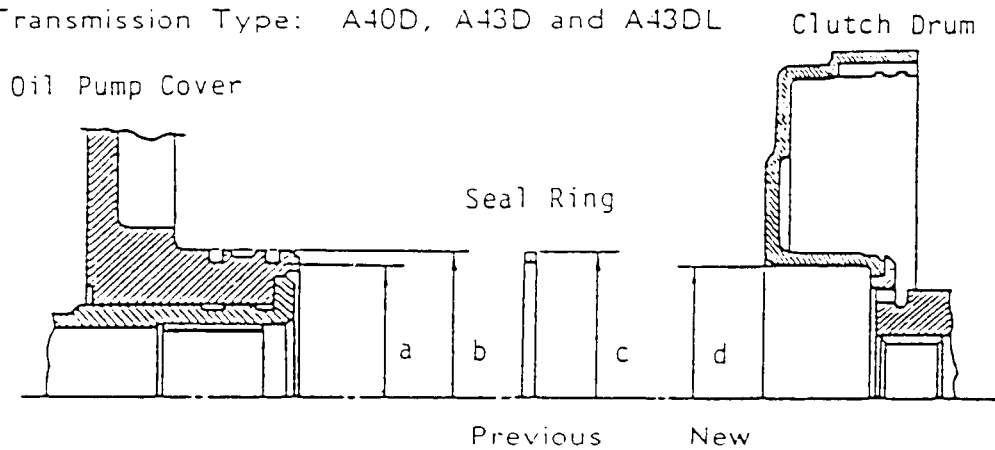

	Previous	New
a. A40D	45.77mm	45.92mm
A43D & A43DL	45.50mm	45.92mm
b. A40D, A43D & A43DL	51.10mm	51.52mm
c. A40D, A43D & A43DL	51.56mm	51.98mm
d. A40D, A43D & A43DL	51.56mm	51.98mm



# Technical Service Information

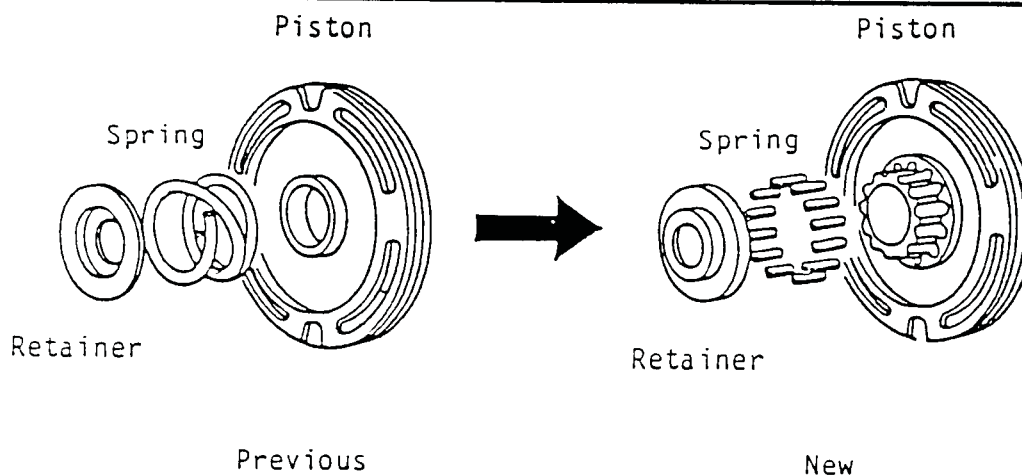

### 3. Clutch Cylinder Oil Seal Ring Portion

Transmission Type: A40, A40D, A43D and A43DL

Effective Date: August, 1981

Description: To improve performance of the oil seal ring of clutch cylinder for the overdrive clutch (C0), front clutch (C1) and rear clutch (C2), the cylinder bore, oil seal ring and ring groove diameters have been increased.

#### (1) Overdrive clutch (C0) oil pump cover

Transmission Type: A40D, A43D and A43DL

Oil Pump Cover

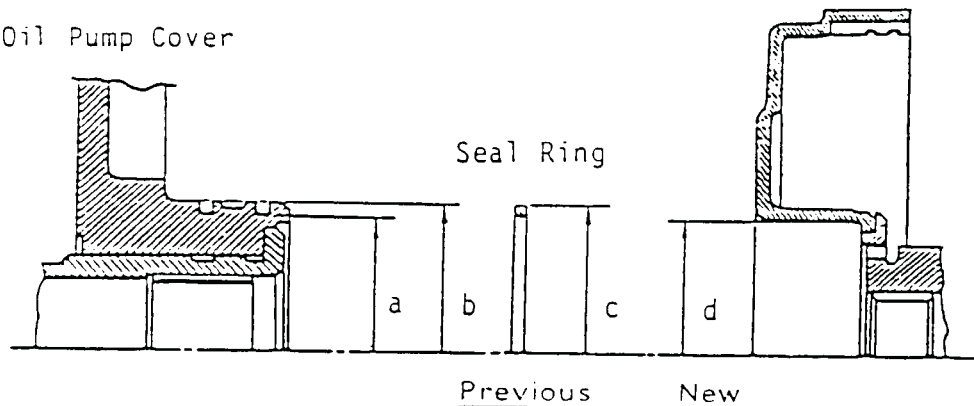

		Previous	New
a.	A40D A43D & A43DL	45.77mm	45.92mm
b.	A40D, A43D & A43DL	51.10mm	51.52mm
c.	A40D, A43D & A43DL	51.56mm	51.98mm
d.	A40D, A43D & A43DL	51.56mm	51.98mm



# Technical Service Information

TITLE 1982 AUTOMATIC TRANSMISSION CHANGES A40, A40D, A43D, A43DL

Front Clutch (C1) Overdrive Case  
(3) Transmission Type: A40D, A43D and A43DL

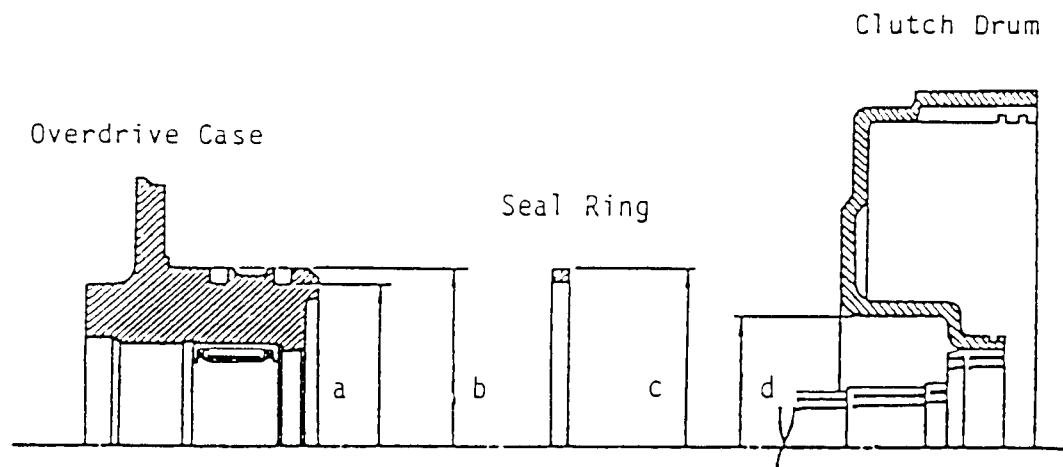

	<u>Previous</u>	<u>New</u>
a.	45.77mm	46.19mm
b.	51.10mm	51.52mm
c.	51.56mm	51.98mm
d.	51.56mm	51.98mm

(4) Rear clutch (C2) center support

Transmission Type: A40, A40D, A43D and A43DL

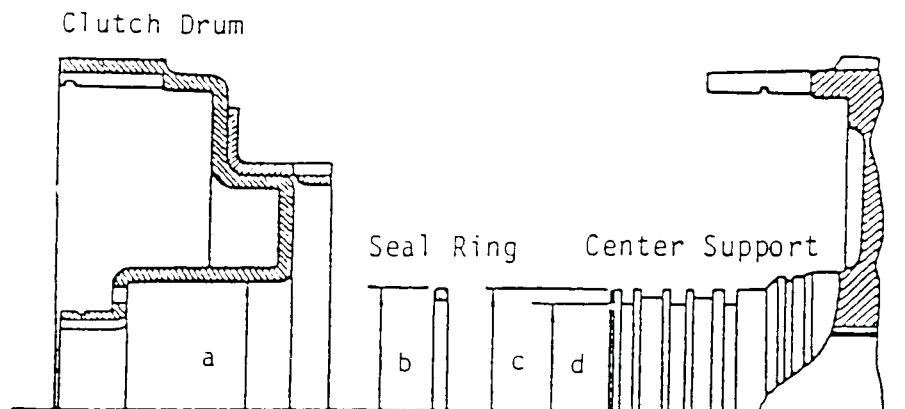

	<u>Previous</u>	<u>New</u>
a.	51.56mm	51.98mm
b.	51.56mm	51.98mm
c.	51.46mm	51.88mm
d.	45.72mm	46.14mm





## Technical Service Information

### 4. Rear Clutch Hub

Transmission Type: A40

Effective Date: August, 1981

Description: To improve durability of the splines on the rear clutch hub, the number of splines has been increased from 8 to 24.

8-splines

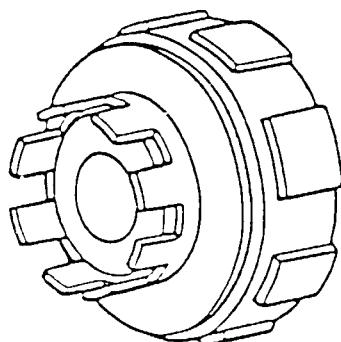

24-splines

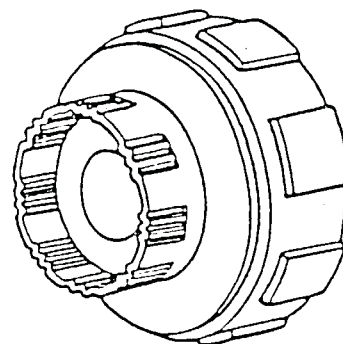

- Remarks:
- 1) This modification has been made on the A43D and A43DL automatic transmissions since production start.
  - 2) This modification will not be made on the A40D automatic transmission.

### 5. Thrust Bearing for Pump Cover and Clutch (C0)

Transmission Type: A43D and A43DL

Effective Date: October, 1981 (A43D), August, 1981 (A43DL)

Description: To increase capacity of the overdrive clutch (C0) thrust bearing, the first thrust bearing has been modified as illustrated below.

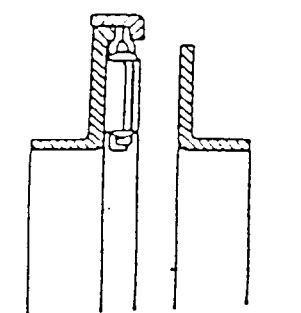
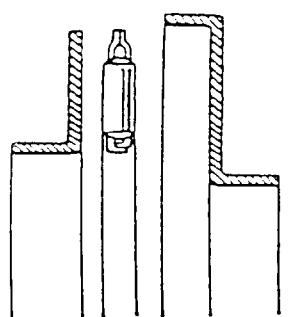



## Toyota ECT

TITLE ELECTRONIC CONTROLLED TRANSMISSION ELECTRICAL DIAGNOSIS

The purpose of this bulletin is to aid in the electrical diagnosis and repair of the ECT transmission.

### CONDITION/CONDITIONS:

- Transmission slips or shudders during acceleration
- Engine hesitation when transmission is engaged
- Fluctuating shifting characteristics

### POSSIBLE ELECTRICAL CAUSE/CAUSES:

- Poor continuity between the ECT computer and main wiring harness
- Poor continuity between wire harness from ECT computer to solenoids
- Shift solenoids
- ECT computer
- Throttle position sensor
- Transmission speed sensors

### CORRECTION:

The following flow chart will assist in the proper diagnosis and repair of these conditions.

Road Test

Verify the stated condition/customer complaint

Preliminary Checks

1. Transmission fluid level and condition
2. Throttle cable adjustment
3. Shift linkage
4. Neutral start switch
5. Idle speed

\* If the fluid is contaminated with evidence of burnt clutches, etc., it may be necessary to proceed to internal checks diagnosis.

Correct as necessary and road test, proceed to harness connector checks if necessary.



# Technical Service Information

TITLE ELECTRONIC CONTROLLED TRANSMISSION ELECTRICAL DIAGNOSIS

## Harness Connector Checks

1. Check connector continuity from wire harness to ECT computer. Check for loose connections, loose connectors, loose or bent pins, or loose wires.
2. Check connector continuity from ECT computer to solenoids. Check for loose connections, loose connectors, loose or bent pins, or loose wires. Perform solenoid operation verification as per the appropriate manual.
3. Check throttle position sensor connections.
4. Check speed sensor connections in transmission and speedometer.

Correct as necessary and road test, proceed to DG terminal checks if necessary.

## DG Terminal Checks

Perform DG terminal checks as per the appropriate repair manual.

Confirm voltage readings with appropriate repair manual specifications. If voltage readings are not within specification, and if good connections/continuity are certain, replace transmission electrical components as necessary.

Correct as necessary and road test, proceed to manual mode road test if necessary.

## Manual Mode Road Test

Unplug the ECT computer from the transmission and verify the following:

Shift lever position	P	R	N	D	2	1
Gear mode	N	R	N	OD	3	1

The manual mode test will check the operation of internal "mechanical" components of the transmission. If discrepancies are found during the manual mode test, internal mechanical components maybe suspected. The transmission should be removed, disassembled and carefully inspected according to the appropriate repair manual.

## Road test to confirm correction.



# Technical Service Information

## DIAGNOSING ELECTRONIC PROBLEMS TOYOTA TRANSMISSIONS A43DE OR A140E

A voltage test must be made at the D.G. (DIAGNOSTIC TERMINAL) located either under the hood, in the left kick panel or the left door arm rest depending on car and model.

An Analog Volt Meter must be used. The following voltages must be obtained:

<u>VOLTAGE AT D.G. TERMINAL</u>	<u>GEAR POSITION</u>
0	1st gear
2	2nd gear
3	2nd lockup
4	3rd
5	3rd lockup
6	O/D
7	O/D lockup

- (1) If voltage rises from 0 to 7 in above sequence the control system is o.k.
- (2) If there is a constant 8 volt indication, the solenoid is defective.
- (3) If there is a constant 4 volt indication, the speed sensor is faulty.
- (4) Stop the vehicle, but do not stop the engine, stopping the engine will cancel all codes from the ECU memory.

### CHECK THE FOLLOWING VOLTAGES

0 VOLTS Volt system normal or defective brake signal

4 VOLTS Faulty speed sensor #2

8 VOLTS Faulty Solenoid

- (5) Inspect throttle position sensor. Turn off the engine, and while slowly depressing the gas pedal, check that the terminal D.G. Voltage rises in sequence.
- (6) Inspect the brake signal:
  - (a) depress the gas pedal to where 8 volts is indicated for the D.G. Terminal
  - (b) depress the brake pedal and check the voltage reading for the D.G. Terminal

Brake pedal depressed	0 volts
Brake pedal released	8 volts.

# Technical Service Information

## ELECTRONICS DIAGNOSIS OF THE A46DE TRANSMISSION

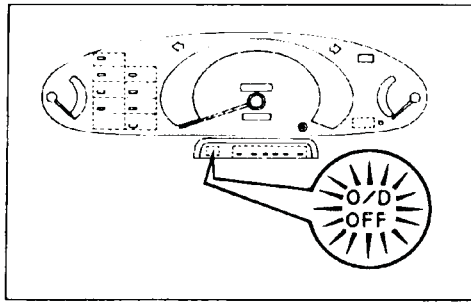

### Diagnosis System

#### DESCRIPTION

1. A self-diagnosis function is built into the electrical control system. Warning is indicated by the overdrive OFF indicator light.

**HINT:** Warning and diagnostic codes can be read only when the overdrive switch is ON. If OFF, the overdrive OFF light is lit continuously and will not blink.

- (a) If a malfunction occurs within the speed sensors (No.1 or 2) or solenoid (No.1 or 2), the overdrive OFF light will blink to warn the driver. However, there will be no warning of a malfunction with lock-up solenoid.

- (b) The diagnostic code can be read by the number of blinks of the overdrive OFF indicator light when terminal TE<sub>1</sub> and E<sub>1</sub> are connected.

- (c) The throttle position sensor or brake signal are not indicated, but inspection can be made by checking the voltage at terminal T of the check connector.

- (d) The signals to each gear can be checked by measuring the voltage at terminal T of the check connector while driving.

2. The diagnostic code (trouble code) is retained in memory by the ECU (of Engine and ECT ECU) and due to back-up voltage, is not canceled out when the engine is turned off. Consequently, after repair, it is necessary to turn the ignition switch off and remove the fuse EFI (15 A) or disconnect the Engine and ECT ECU connector to cancel out the diagnostic (trouble) code.

#### HINT:

- Low battery voltage will cause faulty operation of the diagnosis system. Therefore, always check the battery first.
- Use a voltmeter and ohmmeter that have an impedance of at least 10 k $\Omega$ /V.

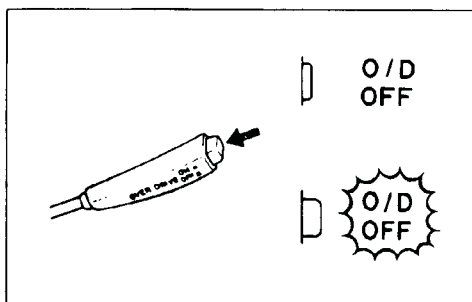
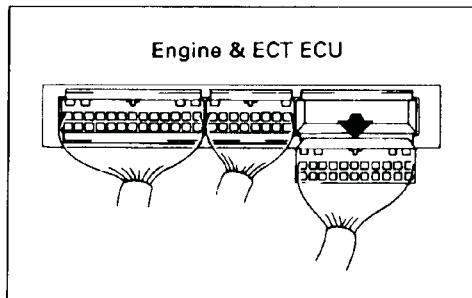
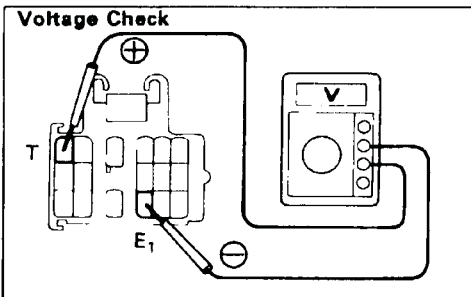
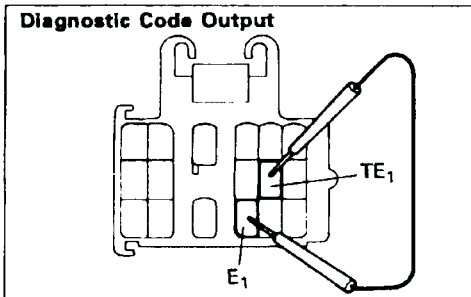

#### CHECK "O/D OFF" INDICATOR LIGHT

1. Turn the ignition switch ON.
2. The "O/D OFF" light will come on when the O/D switch is placed at OFF.
3. When the O/D switch is set to ON, the "O/D OFF" light should go out.

If the "O/D OFF" light flashes when the O/D switch is set to ON, the electronic control system is faulty.



# Technical Service Information

## DIAGNOSTIC CODES

Code No.	Light Pattern	Diagnosis System
—		Normal
42		Defective No. 1 speed sensor (in combination meter) – severed wire harness or short circuit
61		Defective No. 2 speed sensor (in ATM) – severed wire harness or short circuit
62		Severed No. 1 solenoid or short circuit – severed wire harness or short circuit
63		Severed No. 2 solenoid or short circuit – severed wire harness or short circuit
64		Severed lock-up solenoid or short circuit – severed wire harness or short circuit

HINT: If codes 62, 63 or 64 appear, there is an electrical malfunction in the solenoid.

Causes due to mechanical failure, such as a stuck valve, will not appear.

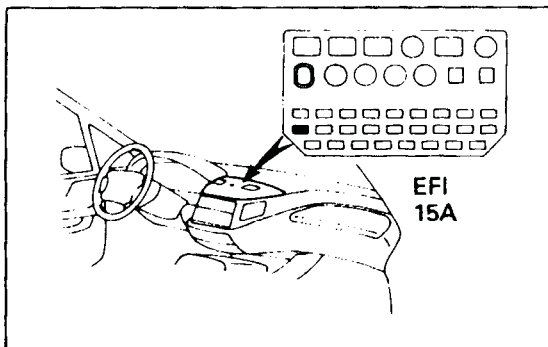

### CANCEL OUT DIAGNOSTIC CODE

1. After repair of the trouble area, the diagnostic code retained in memory by the Engine and ECT ECU must be canceled by removing the fuse EFI (15 A) for 10 seconds or more, depending on ambient temperature (the lower the temperature, the longer the fuse must be left out) with the ignition switch OFF.

HINT:

- Cancellation can be also done by removing the battery negative (-) terminal, but in this case other memory systems will be also canceled out.
- The diagnostic code can be also canceled out by disconnecting the Engine and ECT ECU connector.
- If the diagnostic code is not canceled out, it will be retained by the Engine and ECT ECU and appear along with a new code in event of future trouble.

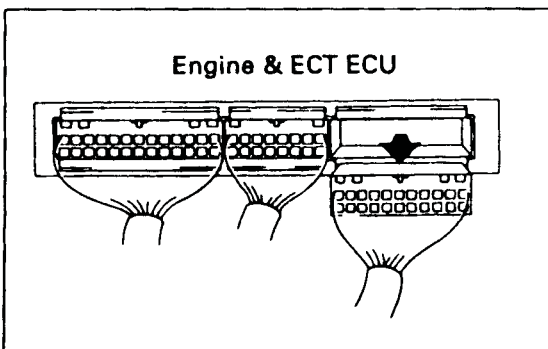

2. After cancellation, perform a road test to confirm that a "normal code" is now read on the O/D OFF light.



# Technical Service Information

## TOYOTA/VOLVO TRANSMISSION IDENTIFICATION

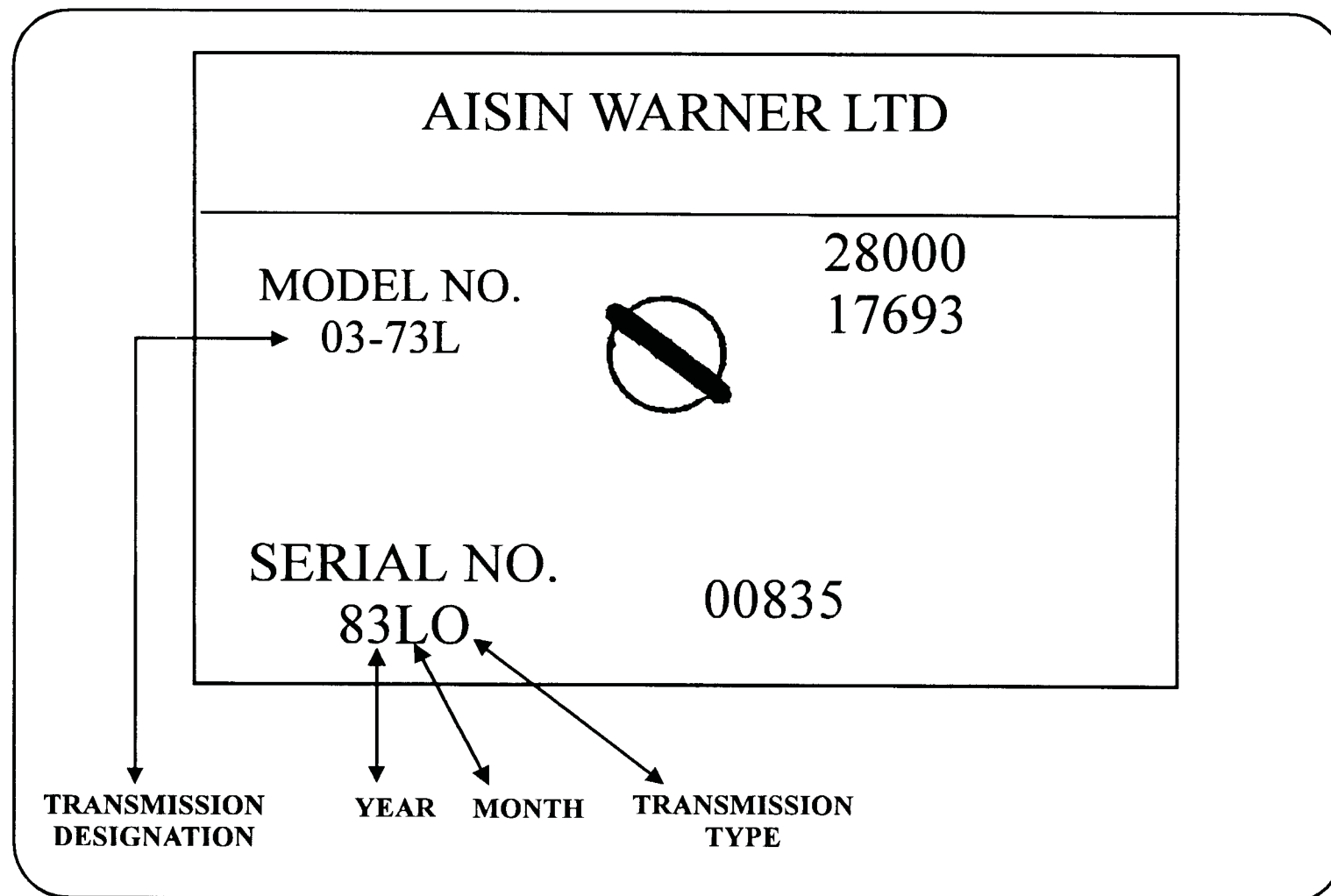

The second serial number indicates month of production

A=JAN.  
B=FEB.  
C=MAR.

D=APR.  
E=MAY  
F=JUNE

G=JULY  
H=AUG  
J= SEPT.

K= OCT.  
L= NOV.  
M=DEC.

The third serial number indicates type of transmission

A=A40  
B=A40D

C=A42D  
D=A41

F=A43D  
G=A43DL

F=A43D  
G=A43

CONTINUED...

# Technical Service Information



## Technical Service Information

### TOYOTA TRANSMISSION IDENTIFICATION

YEAR	MODEL	TRANS. ID	TRANS. MODEL
1980	CELICA	03-55	A-40
1981-85	CELICA	03-50/51	A-40D
1980-81	COROLLA	03-55	A-40
1982-83	COROLLA	03-56	A-41
1982-83	COROLLA	03-50/51	A-40D
1984-87	COROLLA	03-70L	A-42DL
1980	CRESSIDA	03-50/51	A-40D
1981	CRESSIDA	03-71	A-43D
1982	CRESSIDA	03-71L	A-43L
1983-86	CRESSIDA	03-71LE	A-43DE
1980	PICKUP	03-55	A-40
1981	PICKUP	03-75	A-43
1982-84	PICKUP	03-71	A-43D
1985-93	PICKUP	03-71	A-43D
1991-93	PREVIA	03-71LE	A-46DE
1991-93	PREVIA	-----	A-46DF
1980	SUPRA	03-50/51	A-40D
1981	SUPRA	03-71	A-43D
1982	SUPRA	03-71L	A-43DL
1983-85	SUPRA	03-71LE	A-43DE
1984-86	VAN	03-72	A-44DL
1987-89	VAN	03-72L	A-45L
1987-89	VAN	-----	A-45DF
1989-91	4 RUNNER	03-72	A-44DL

### VOLVO TRANSMISSION IDENTIFICATION

1980-81	240	03-55	AW55
1980-84	240	BW55	BW55
1982-91	240	03-70	AW70
1982-85	240	03-71	AW71
1980-82	260	BW55	BW55
1983-91	700 SERIES	03-71	AW71
1983-91	700 SERIES	03-71	AW71
1987-91	700 SERIES	03-70L	AW70L
1987-91	700 SERIES	03-70L	AW70L
1991-93	940	03-72L	AW72L
1991-93	940	03-71	AW71

## Technical Service Information





# Technical Service Information

## TOYOTA A40 CHECK BALL LOCATION

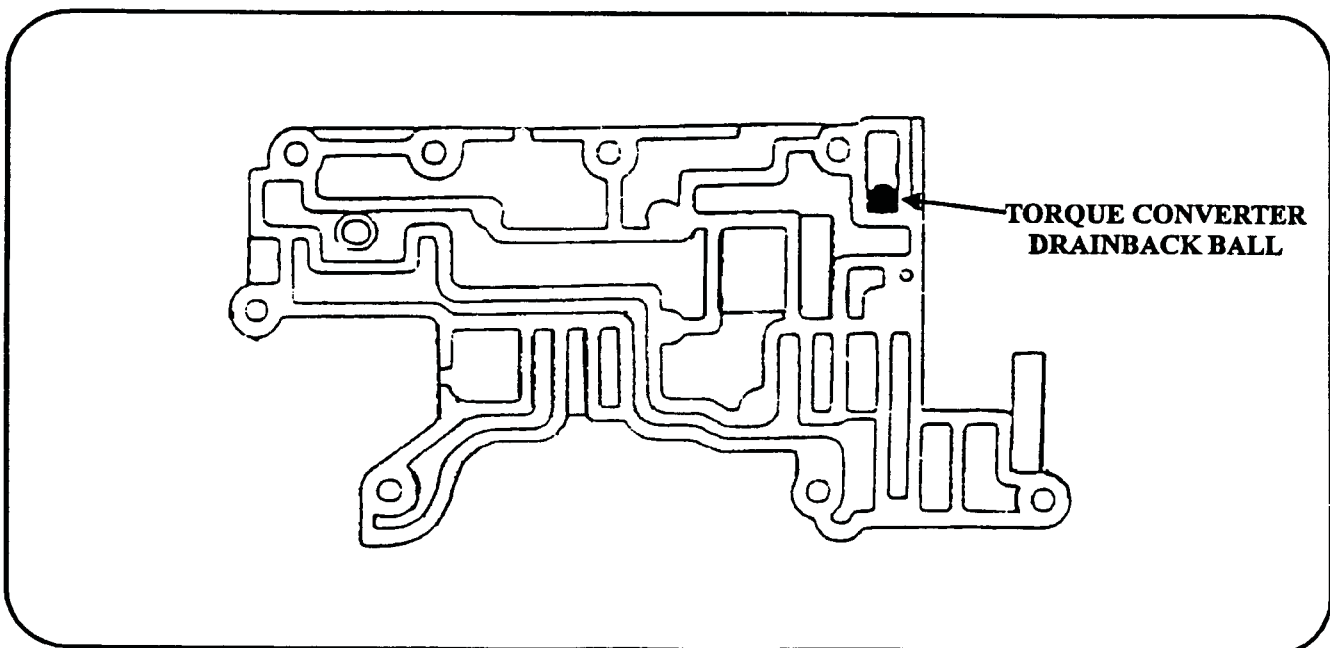
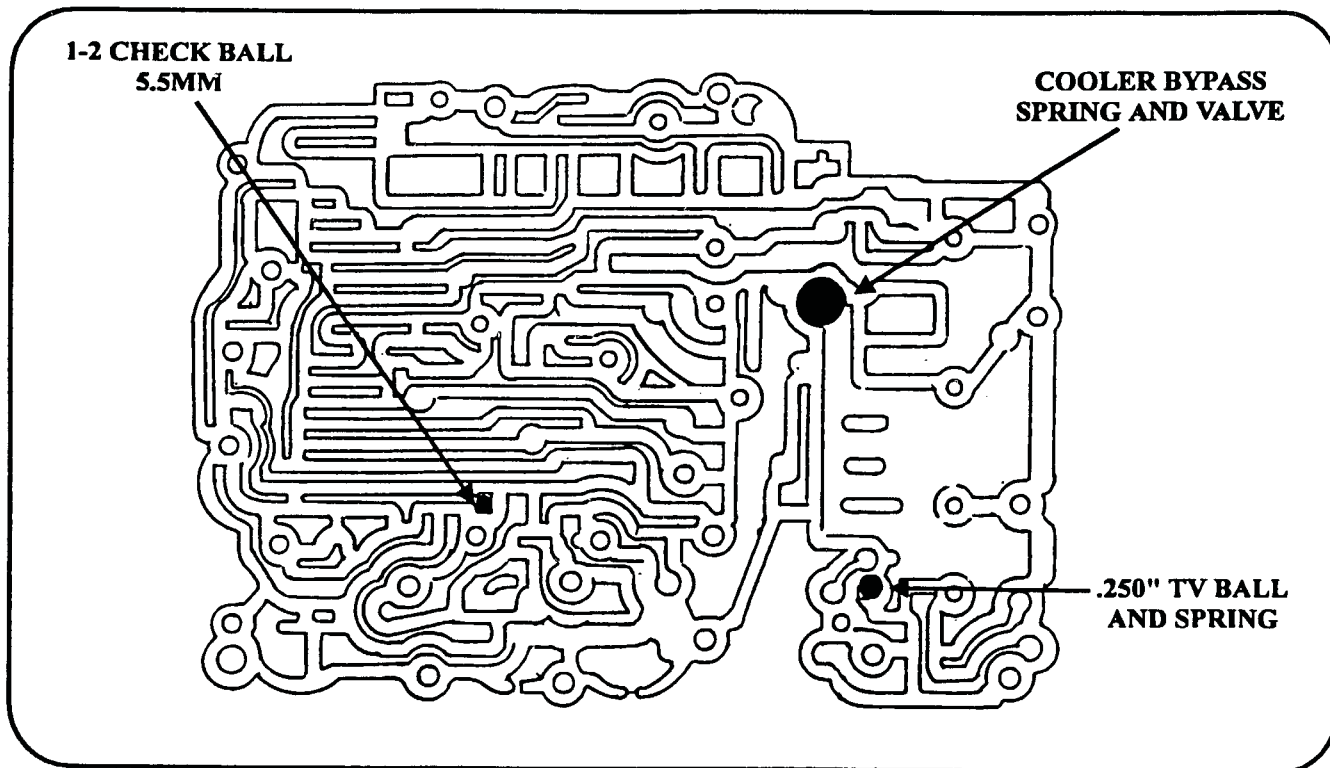

AUTOMATIC TRANSMISSION SERVICE GROUP



Technical Service Information

**TOYOTA A40 CHECK BALL LOCATION**

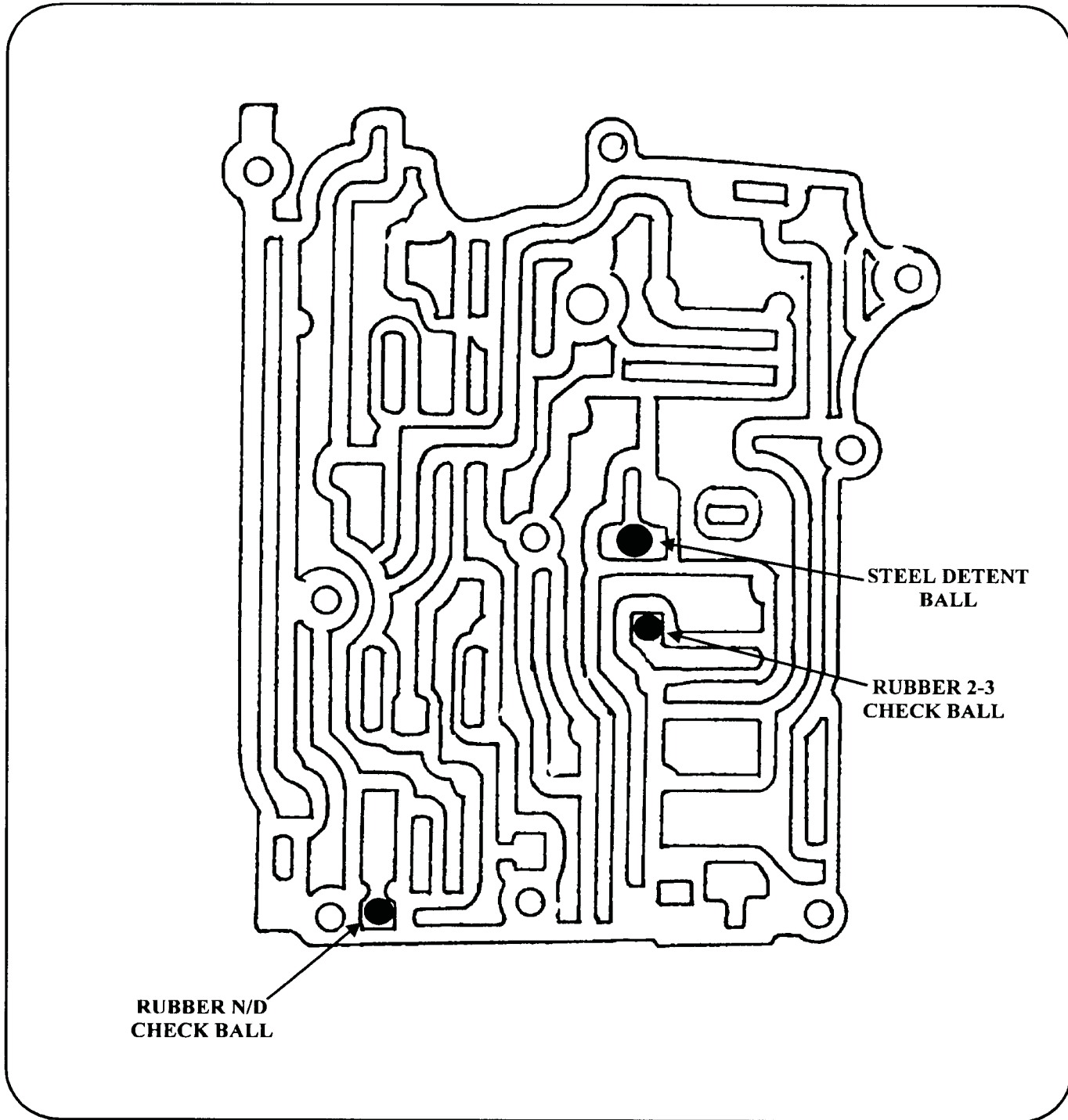

AUTOMATIC TRANSMISSION SERVICE GROUP



## Technical Service Information

# TOYOTA A40D CHECK BALL LOCATION

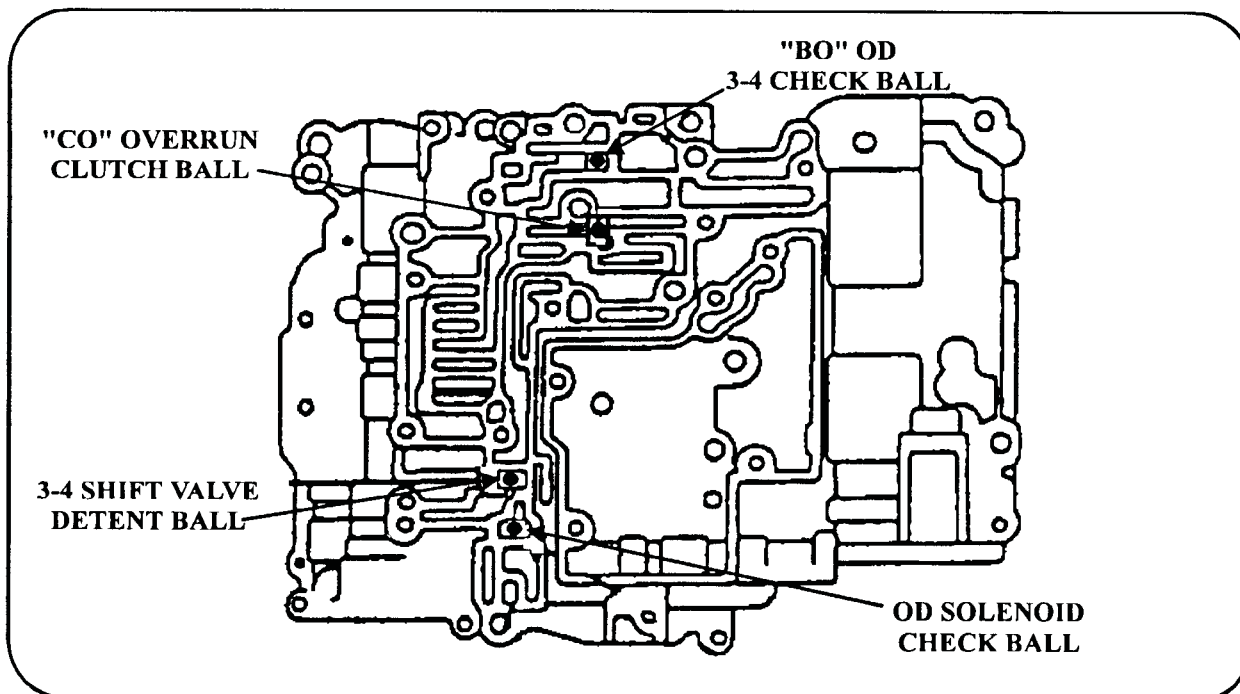
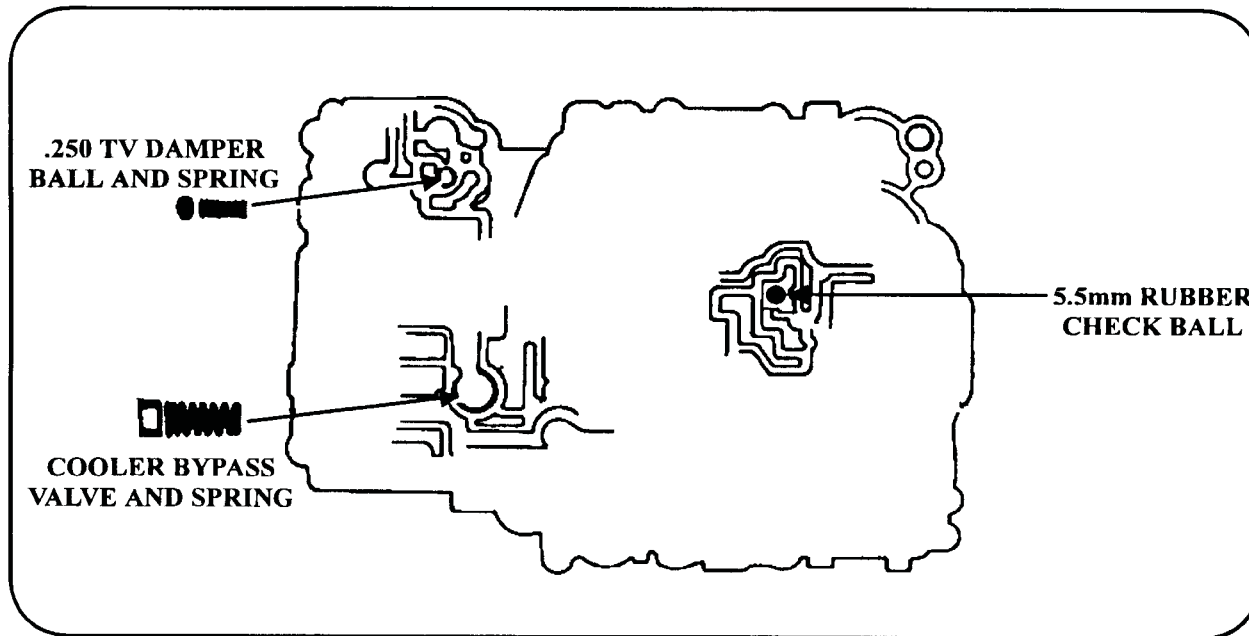

AUTOMATIC TRANSMISSION SERVICE GROUP



# Technical Service Information

## TOYOTA A40D CHECK BALL LOCATION

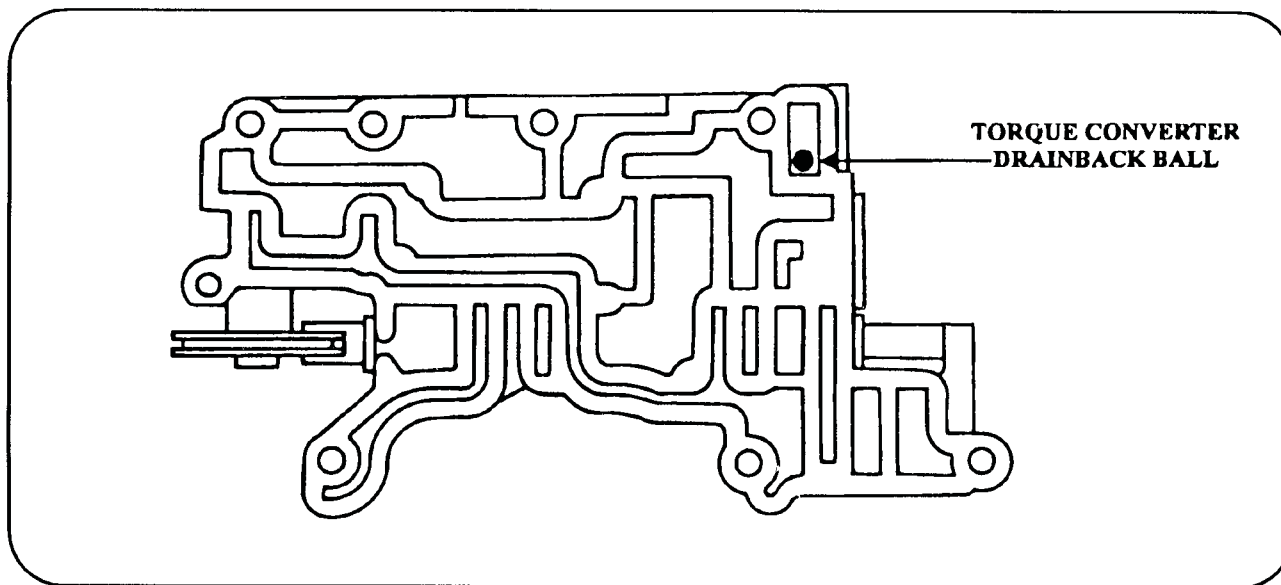
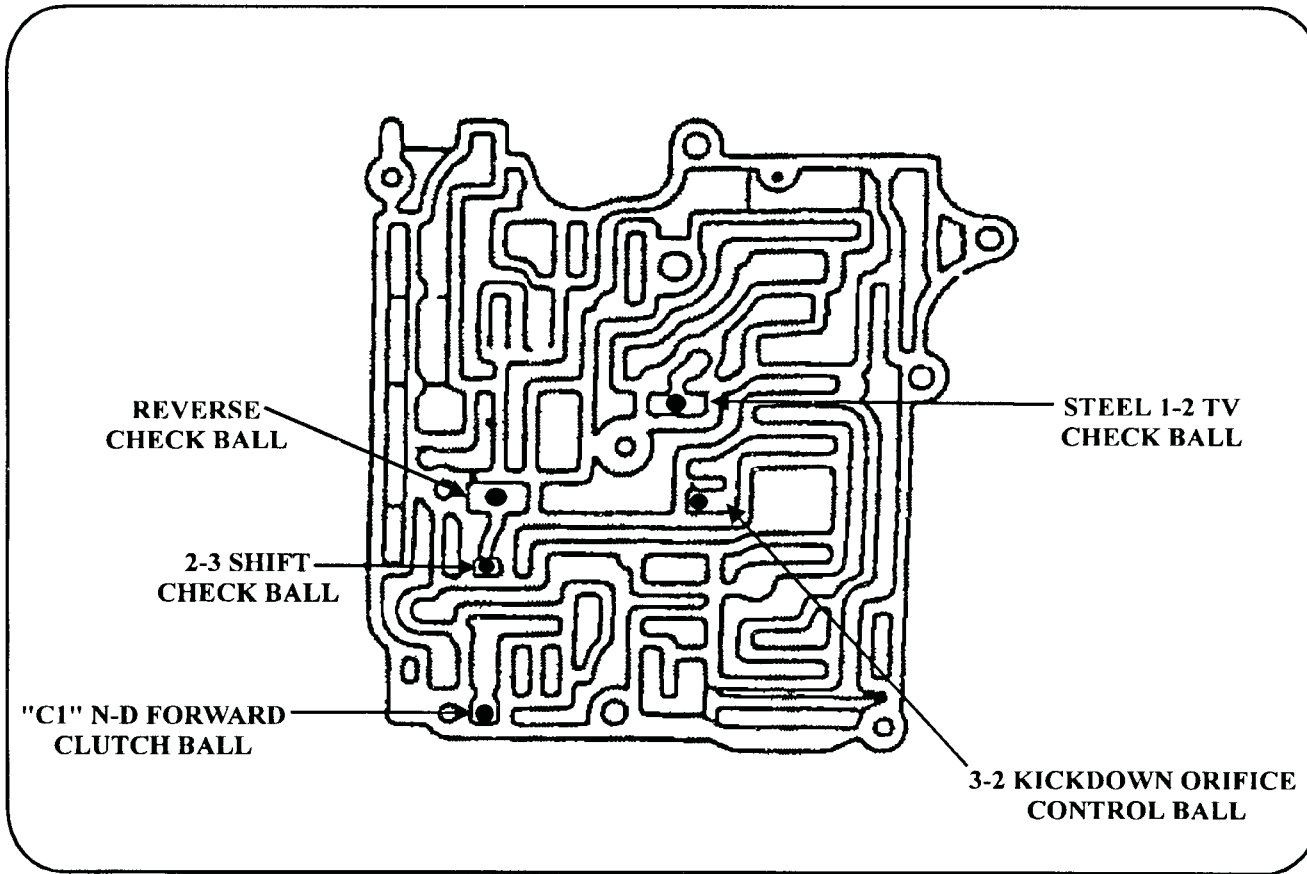

Technical Service Information



## Technical Service Information

# TOYOTA A43D CHECK BALL LOCATION

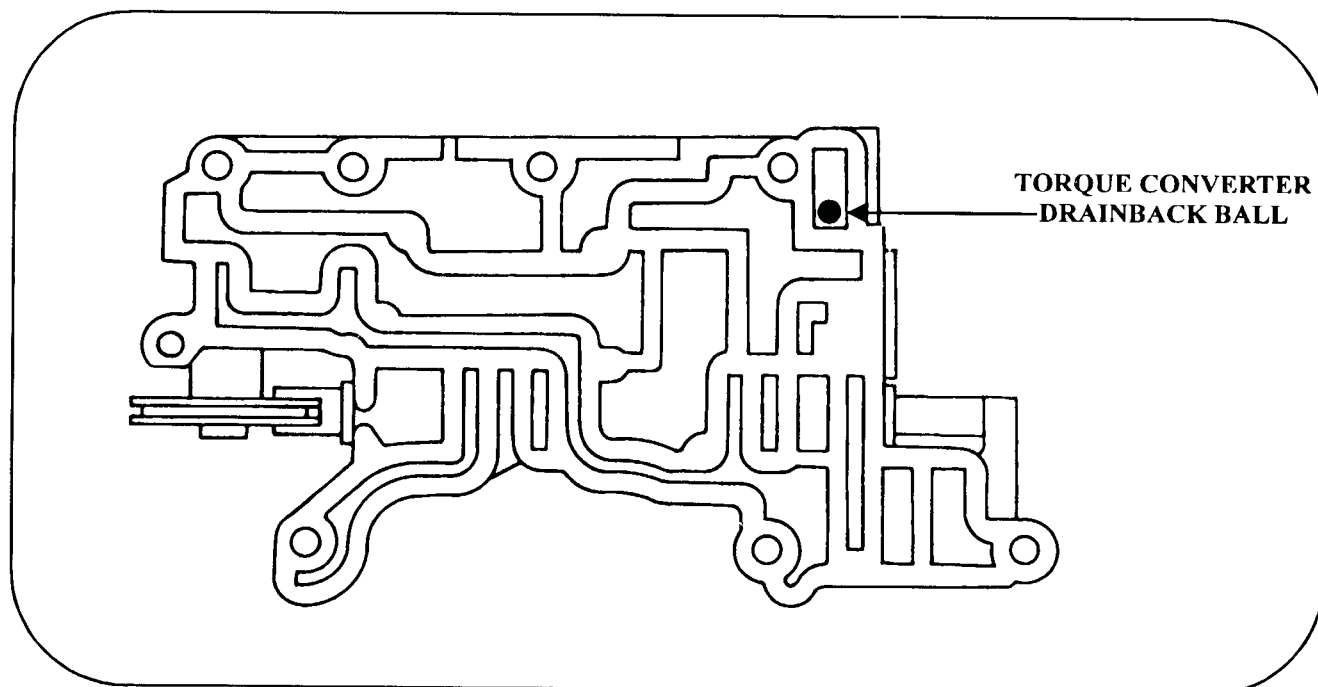
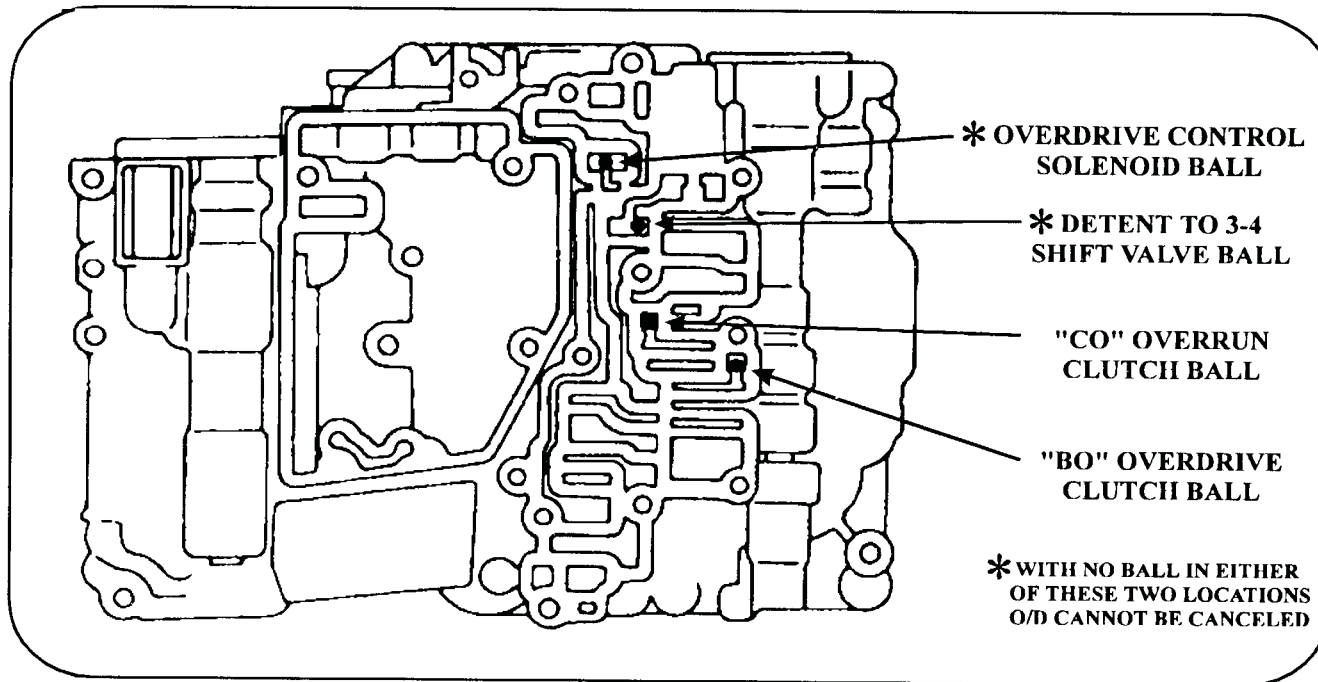

AUTOMATIC TRANSMISSION SERVICE GROUP

# TOYOTA A43D CHECK BALL LOCATION

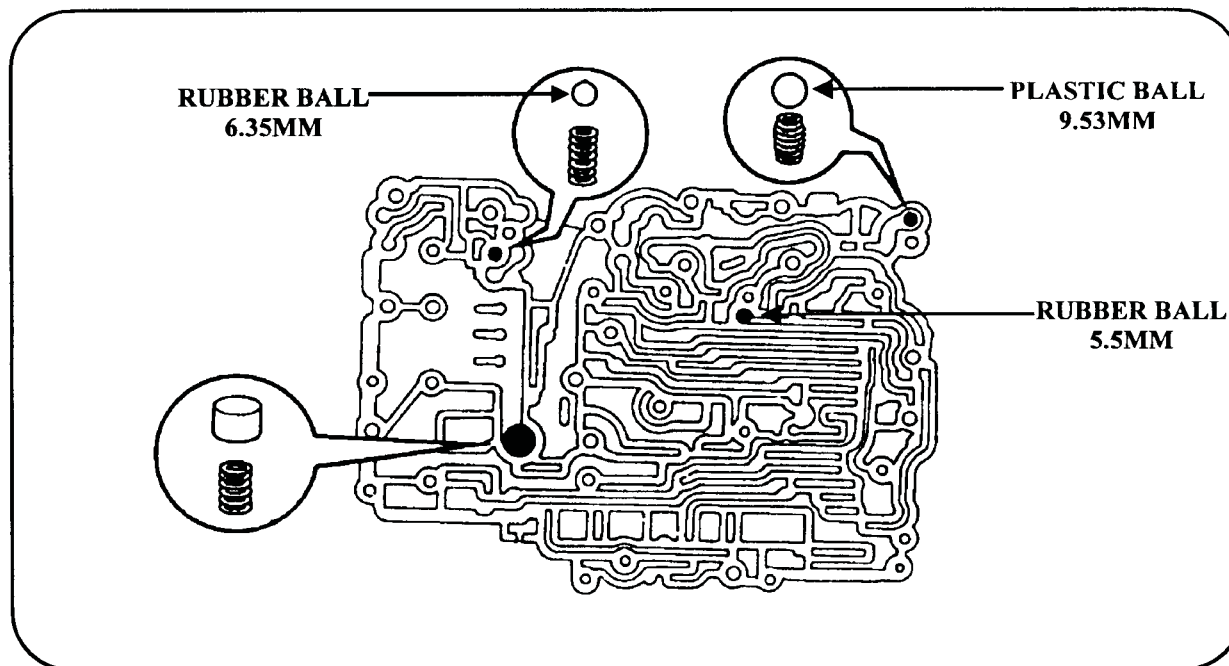
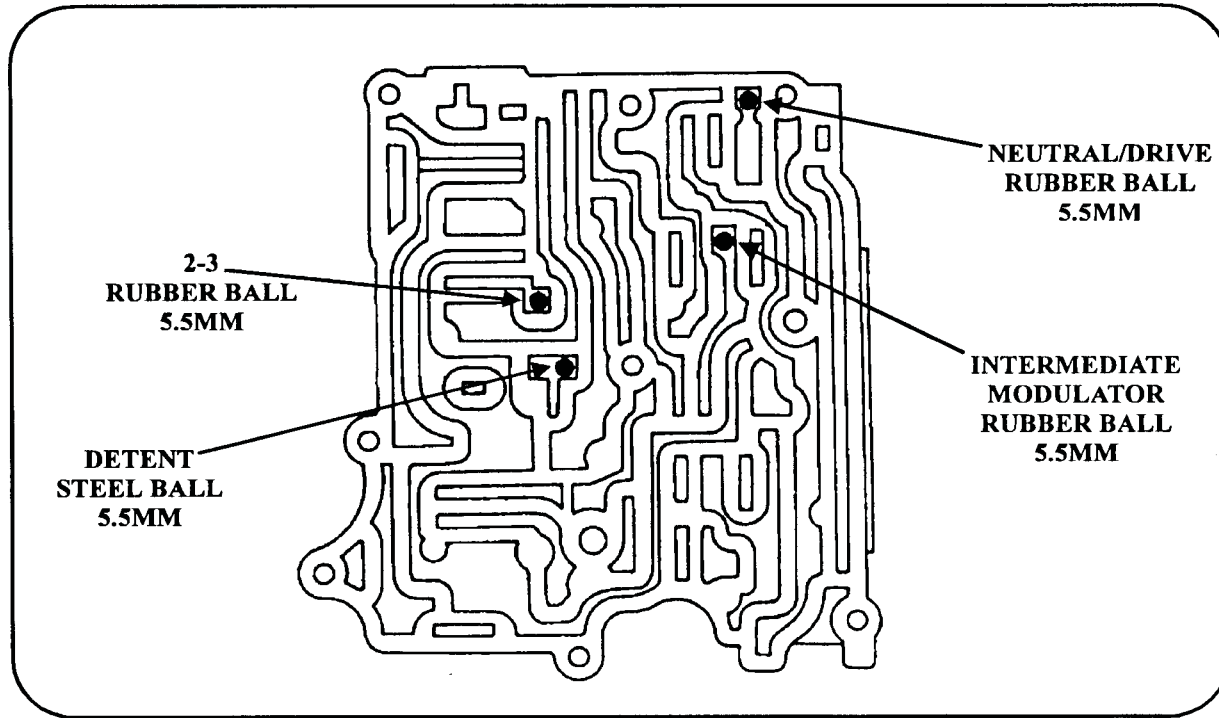



## Technical Service Information

### TOYOTA A43DL CHECK BALL LOCATION

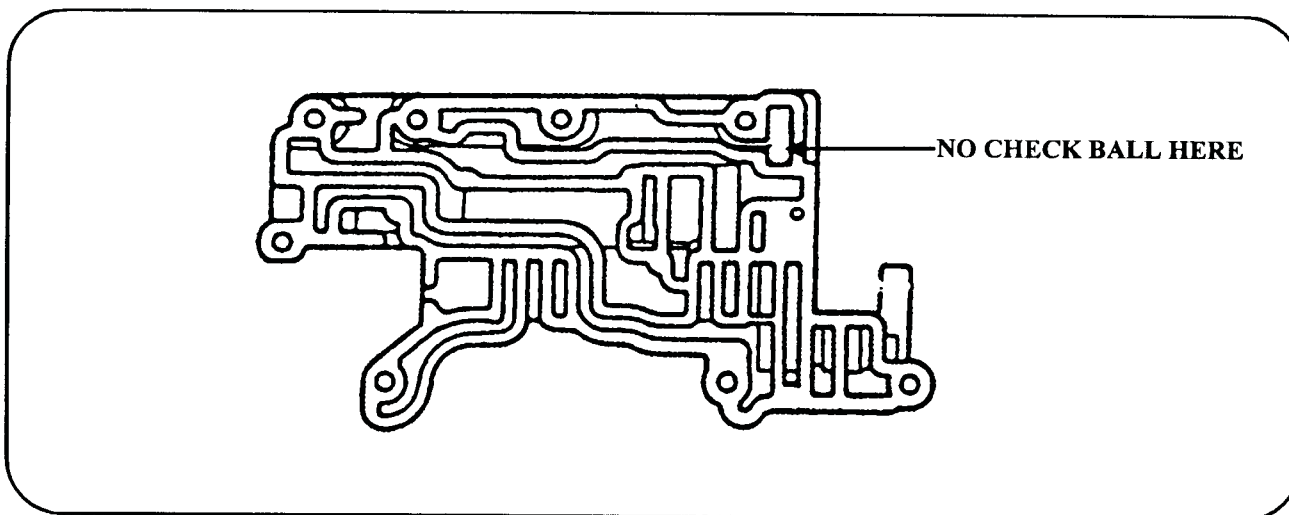
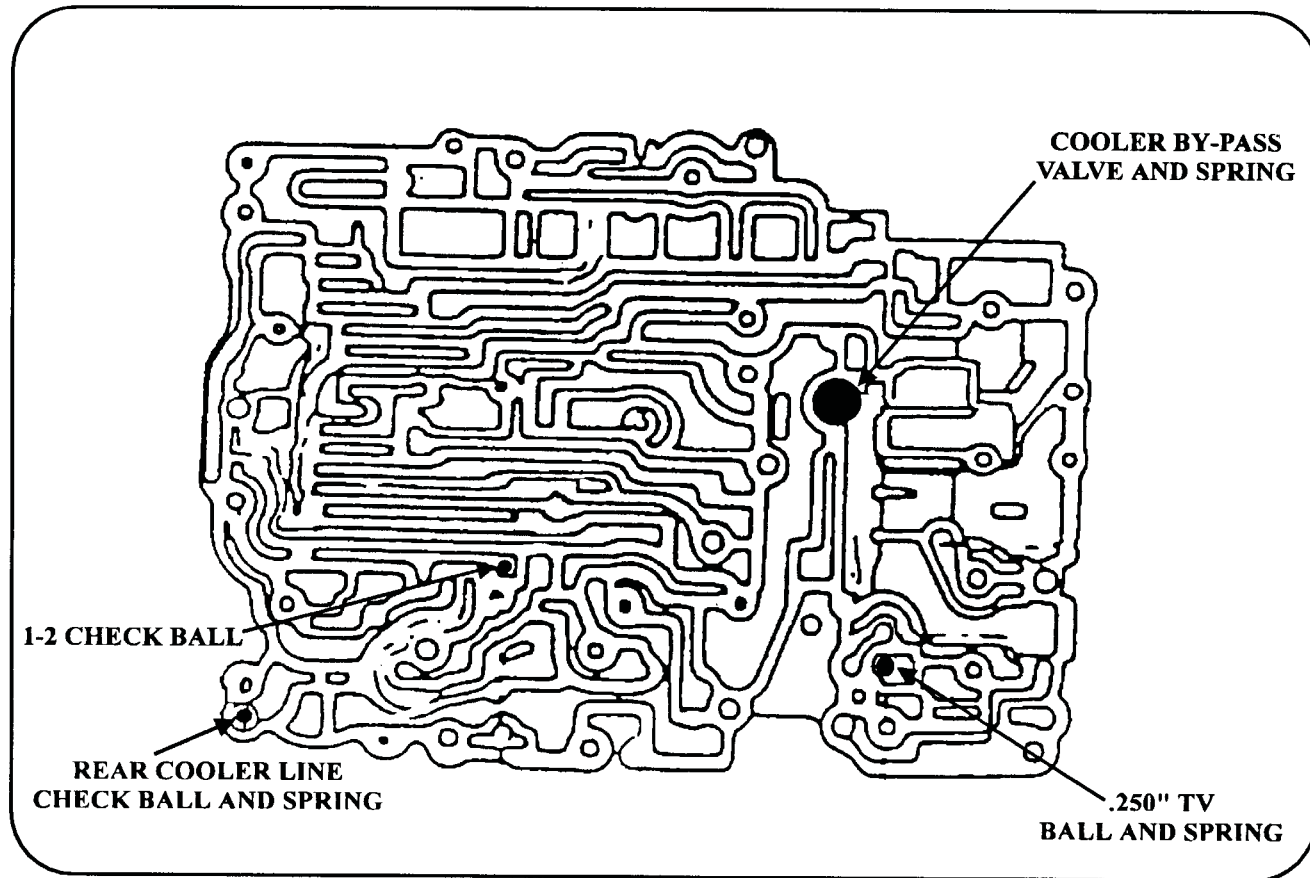

Technical Service Information



# TOYOTA A43DL CHECK BALL LOCATION

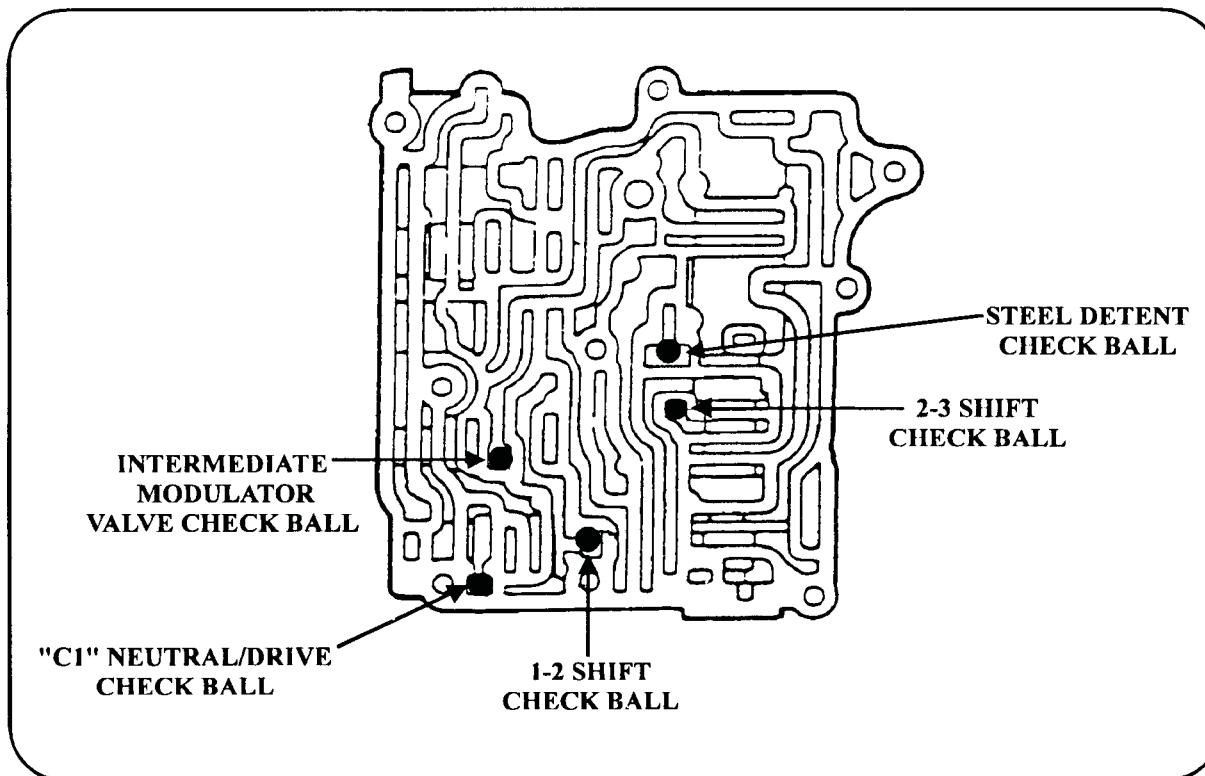
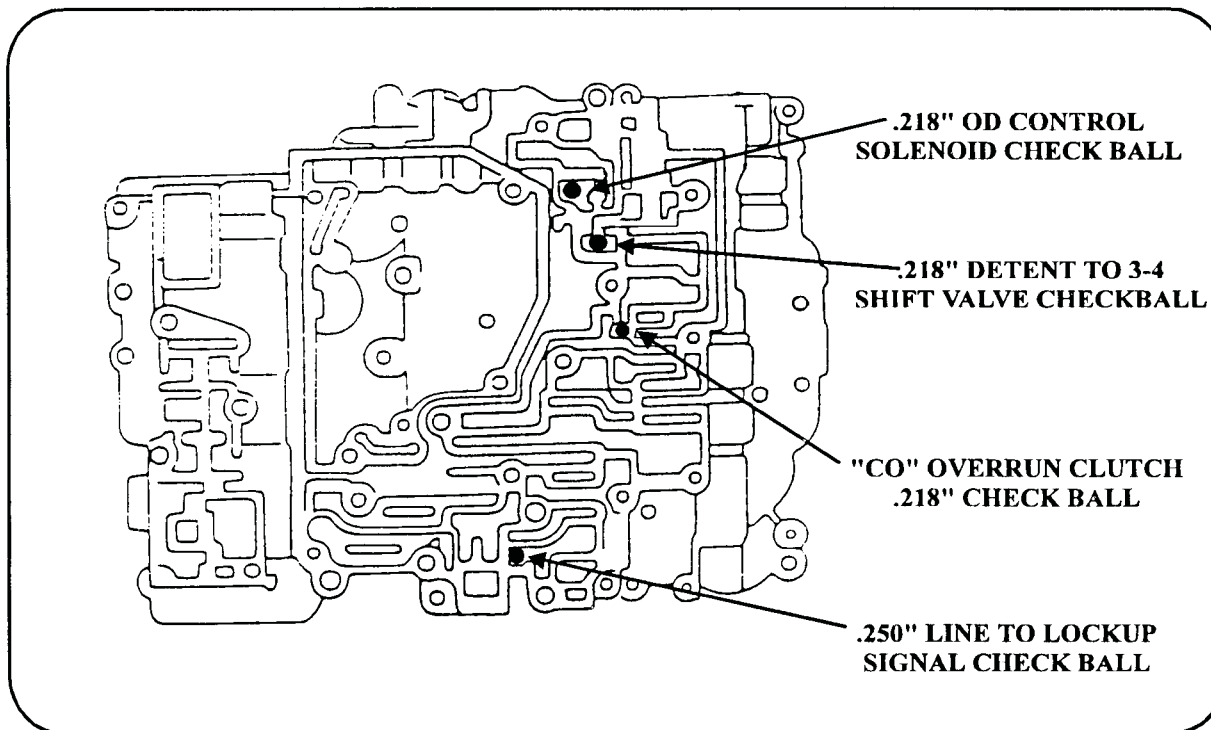





# Technical Service Information

## TOYOTA A43DE CHECK BALL LOCATION

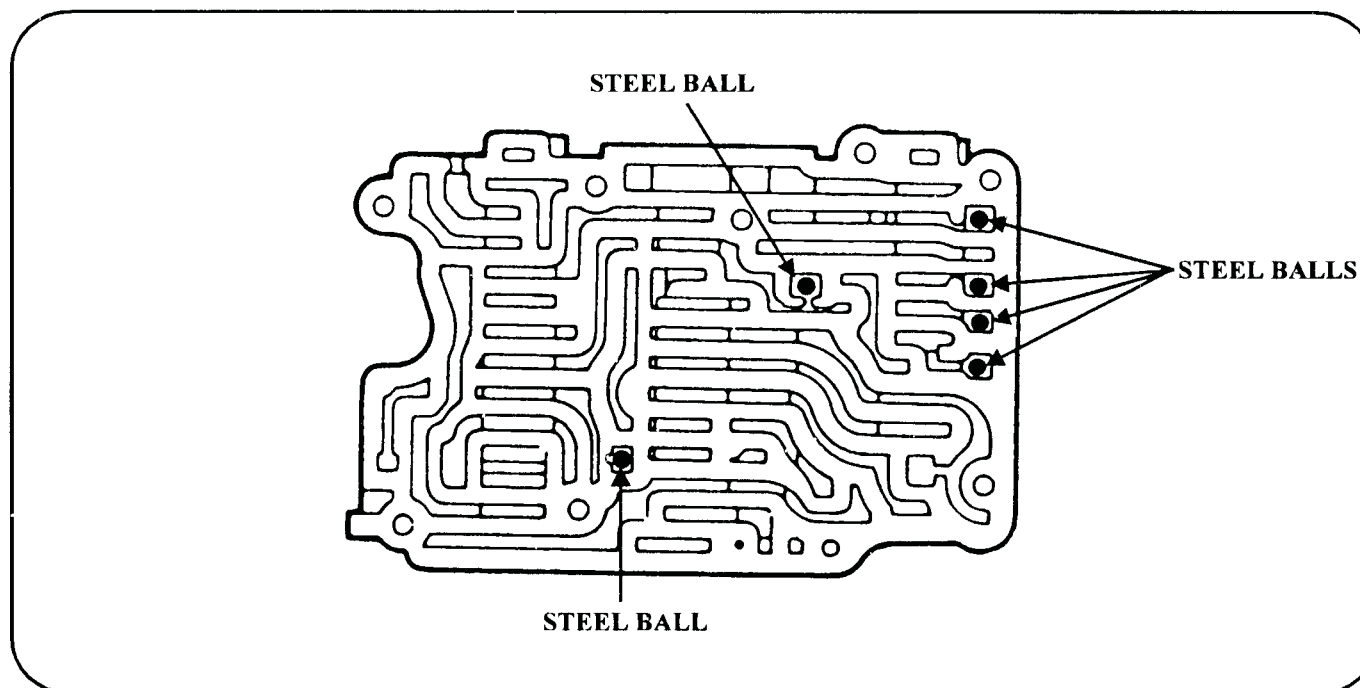
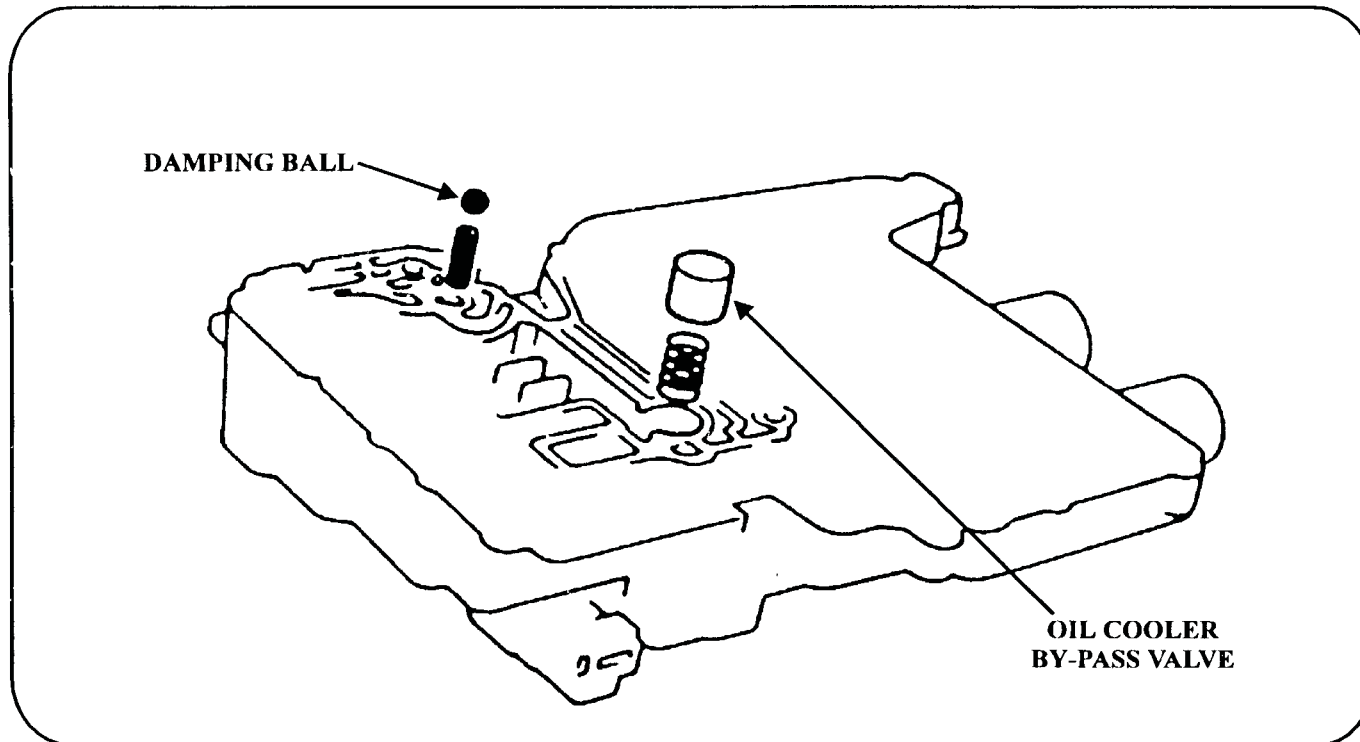

Technical Service Information



# Technical Service Information

## VOLVO BW55 CHECK BALL LOCATION

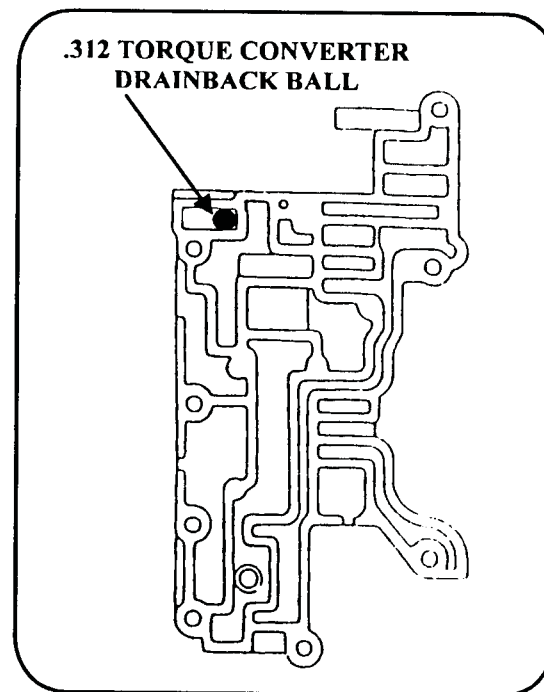
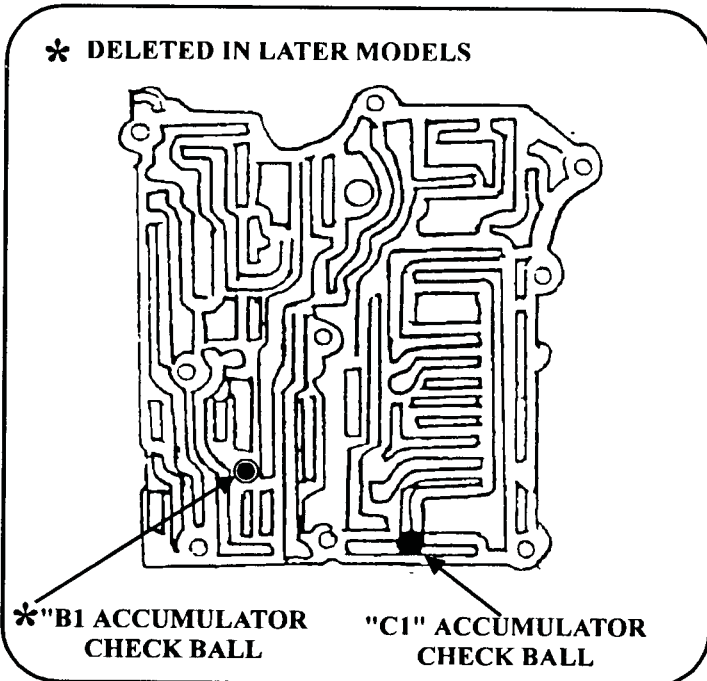
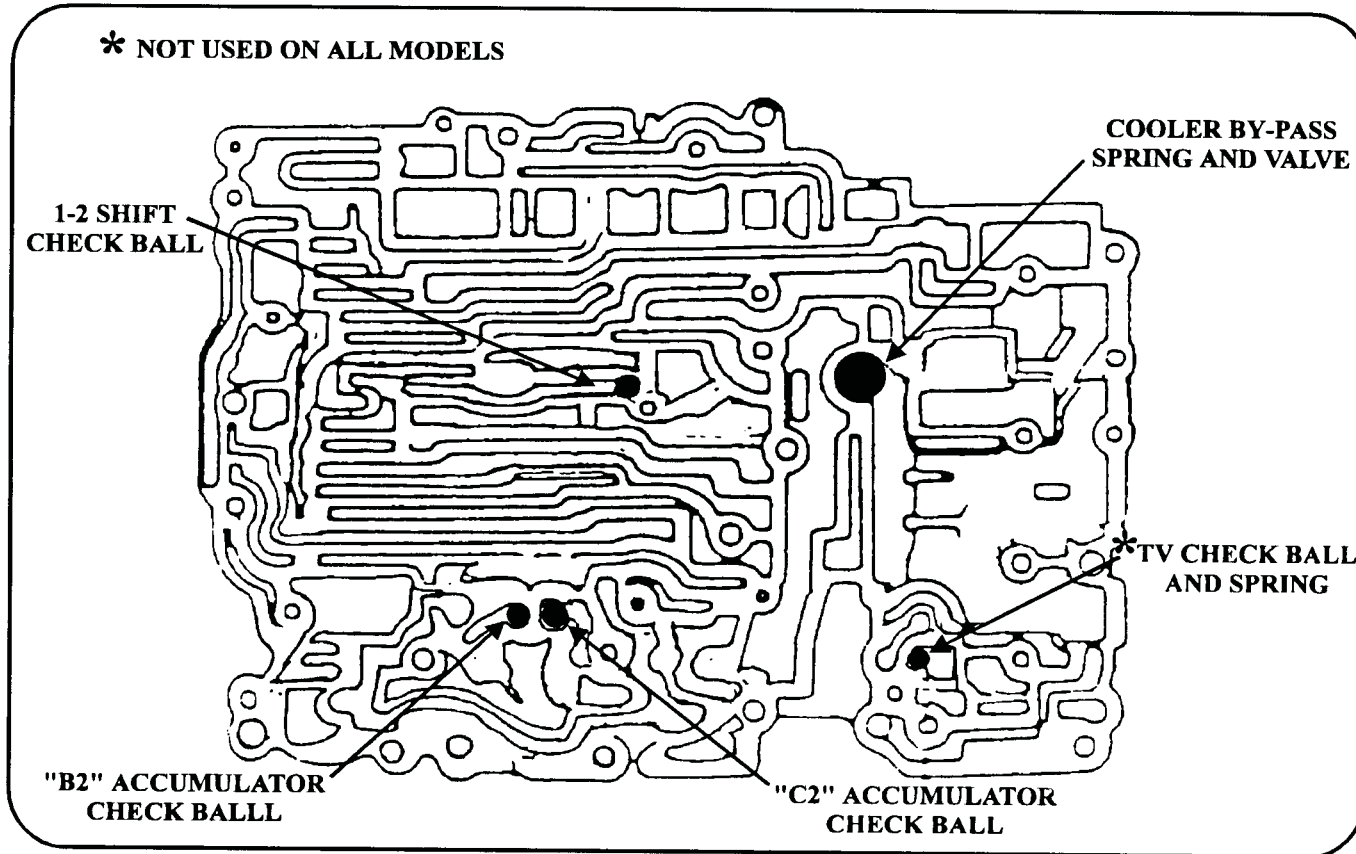

# Technical Service Information



## Technical Service Information

# VOLVO AW55, 70, 71 CHECK BALL LOCATION

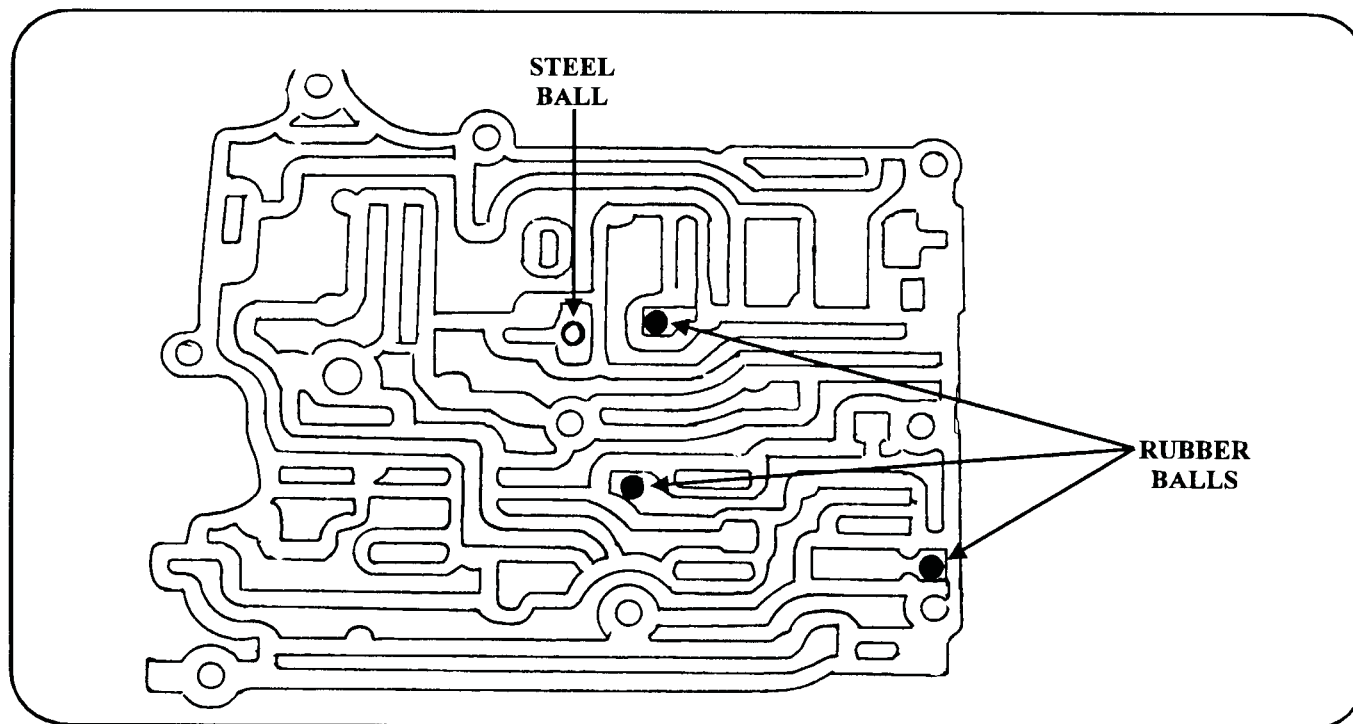
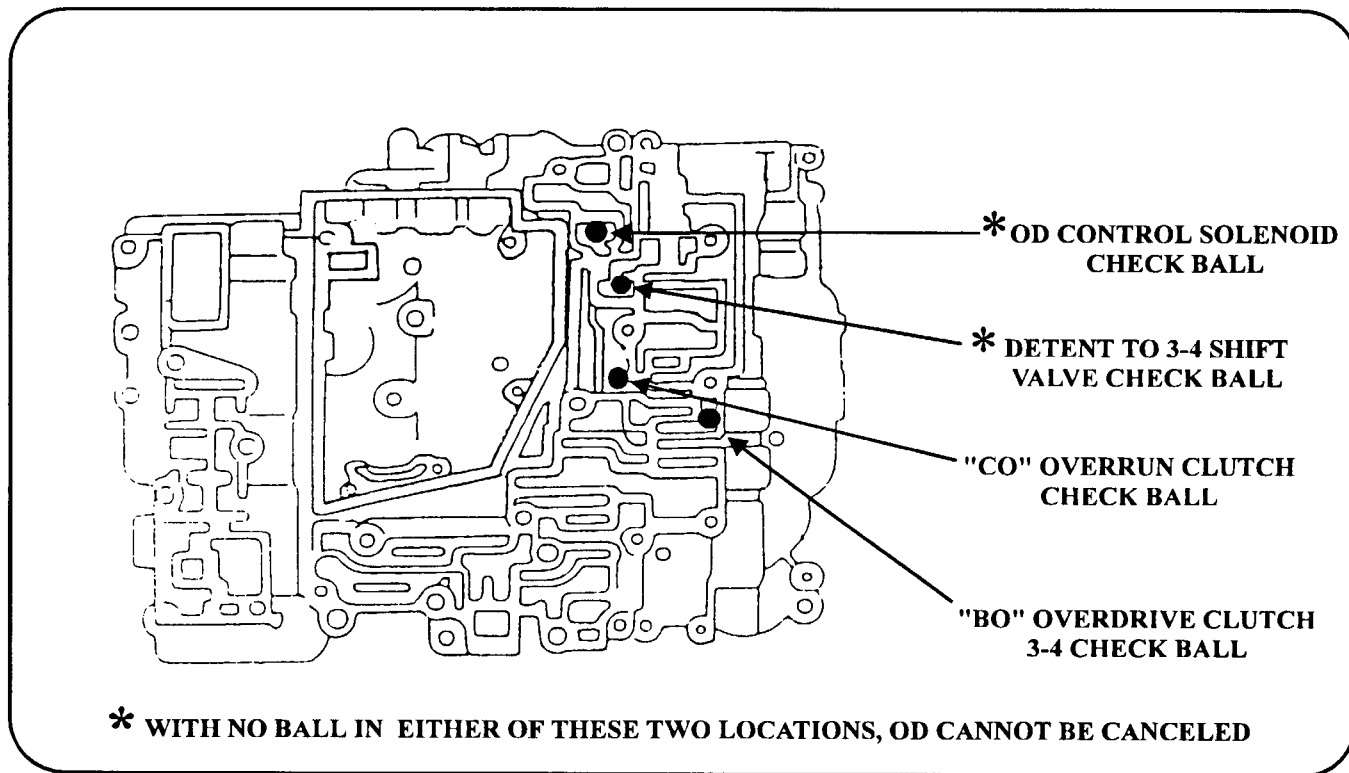

Technical Service Information



# Technical Service Information

## VOVO AW55, 70, 71 CHECK BALL LOCATION

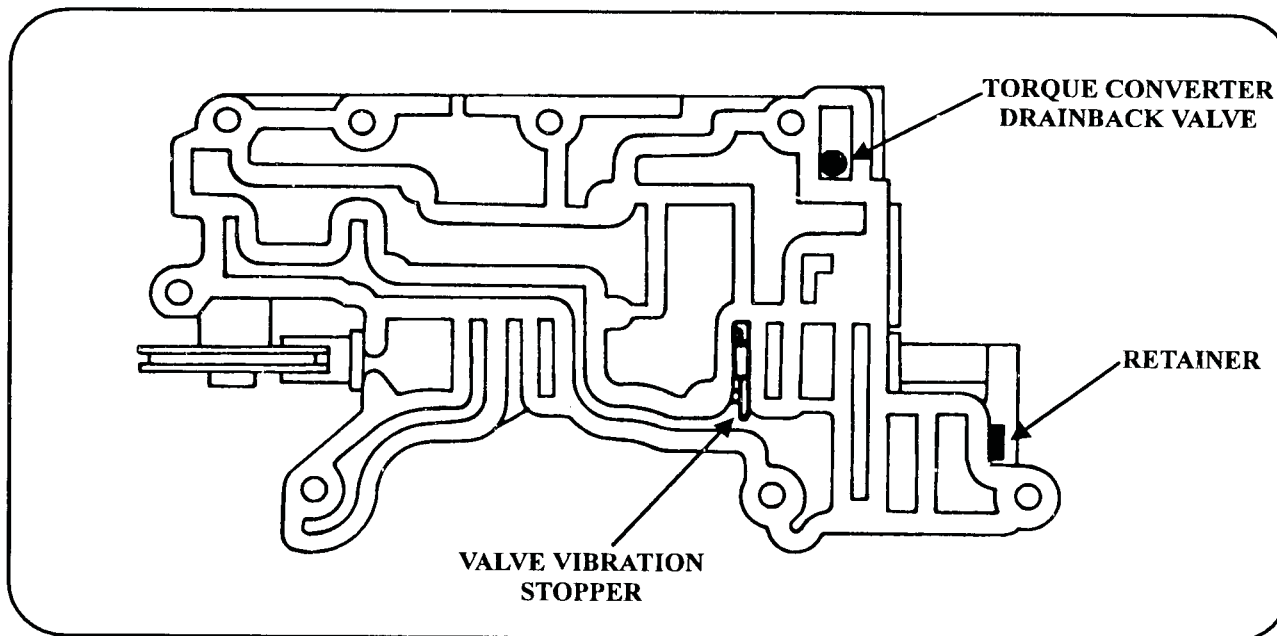
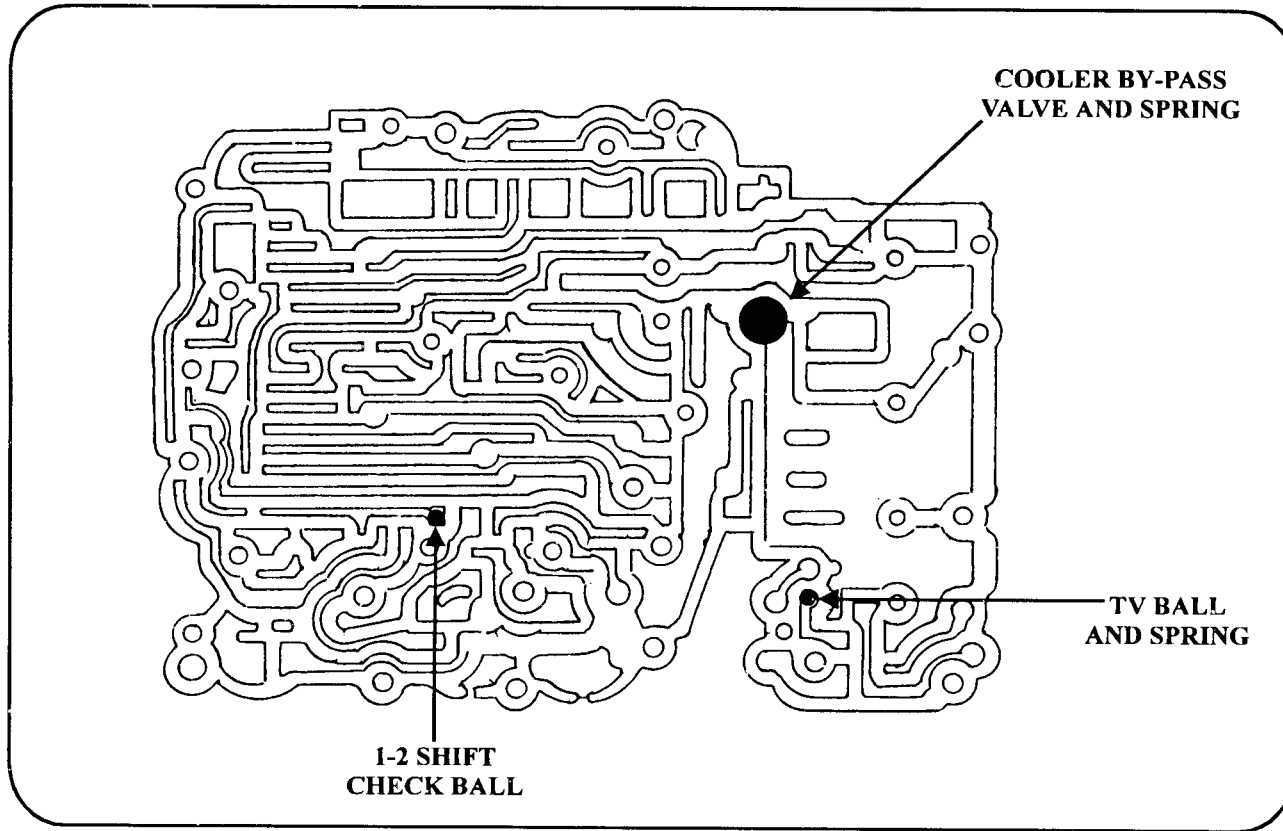

# Technical Service Information



## Technical Service Information

# TOYOTA A44DL CHECK BALL LOCATION TOYOTA A45DL CHECK BALL LOCATION

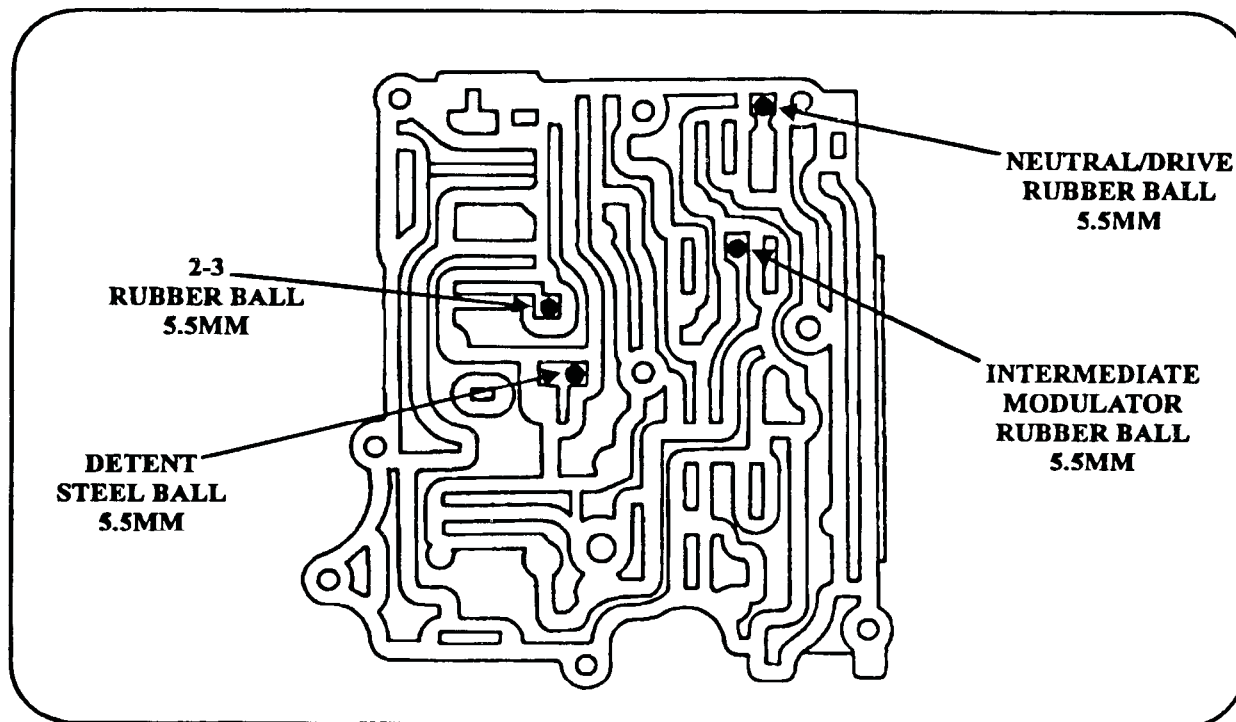
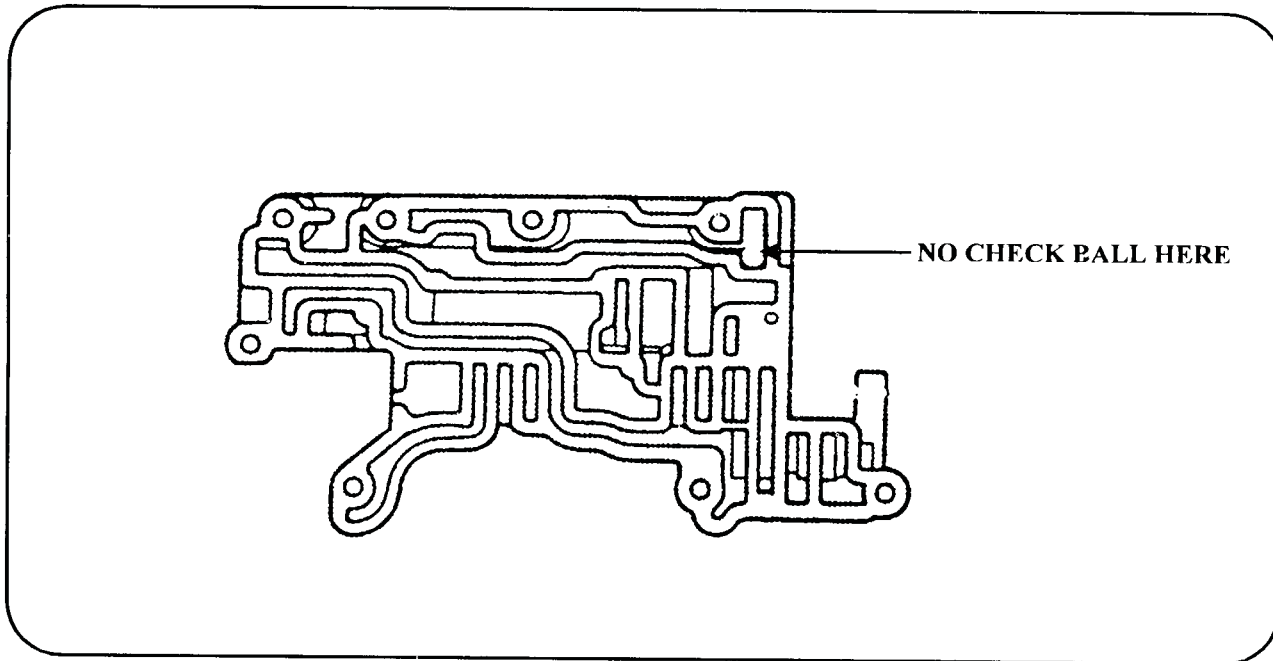

AUTOMATIC TRANSMISSION SERVICE GROUP



## Technical Service Information

# TOYOTA A44DL CHECK BALL LOCATION TOYOTA A45DL CHECK BALL LOCATION

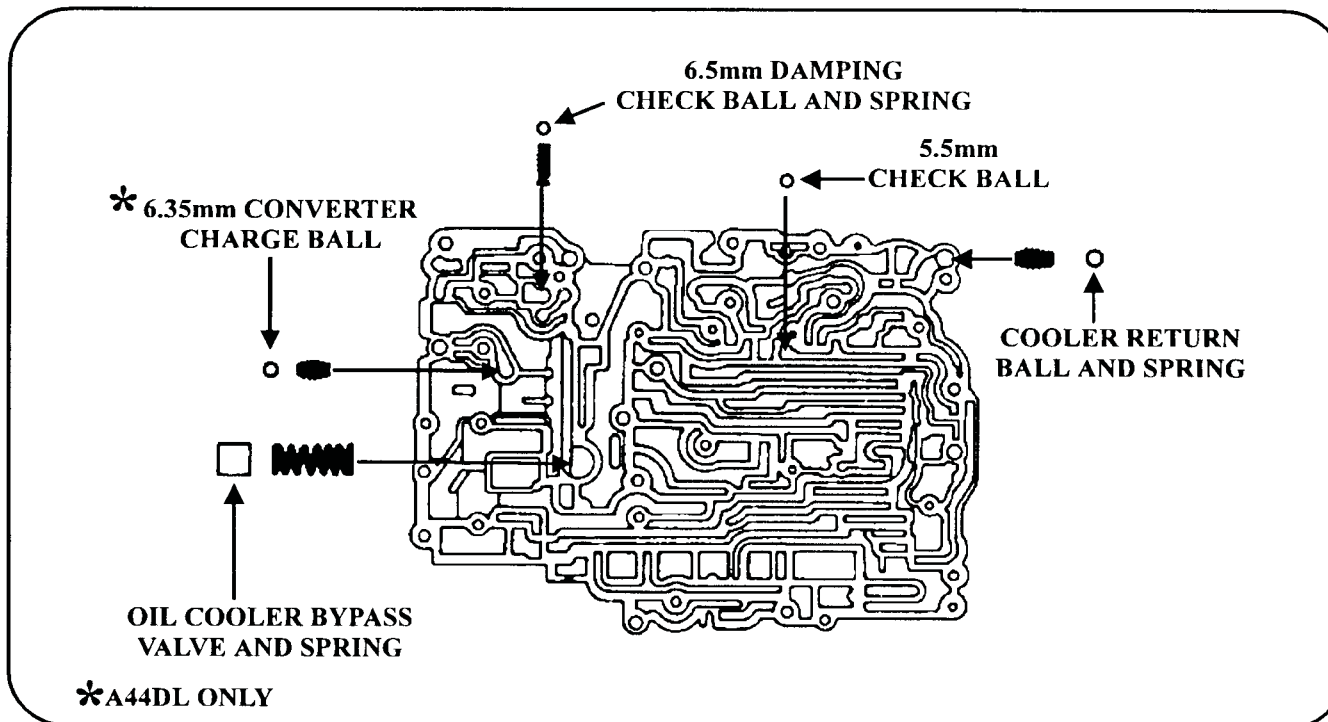
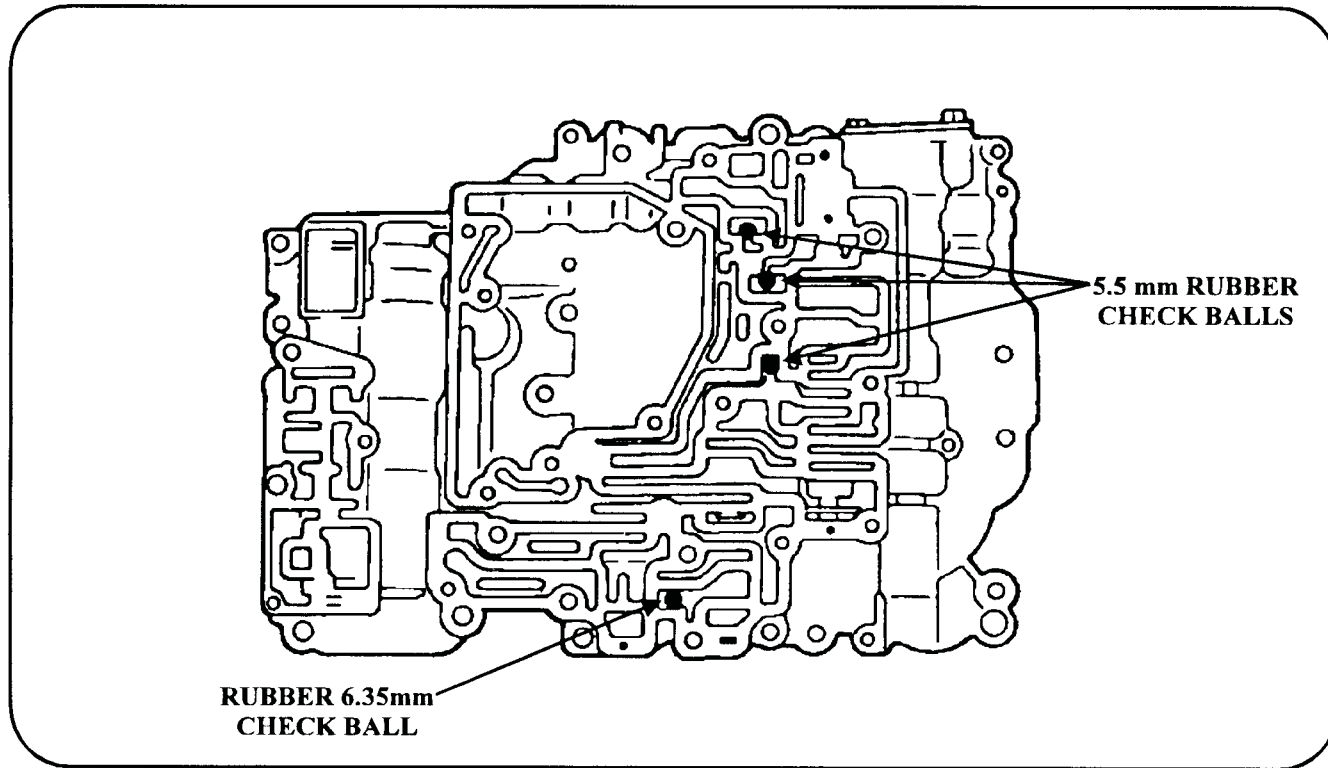

AUTOMATIC TRANSMISSION SERVICE GROUP



## Technical Service Information

### TOYOTA A46DE CHECK BALL LOCATION TOYOTA A46DF CHECK BALL LOCATION

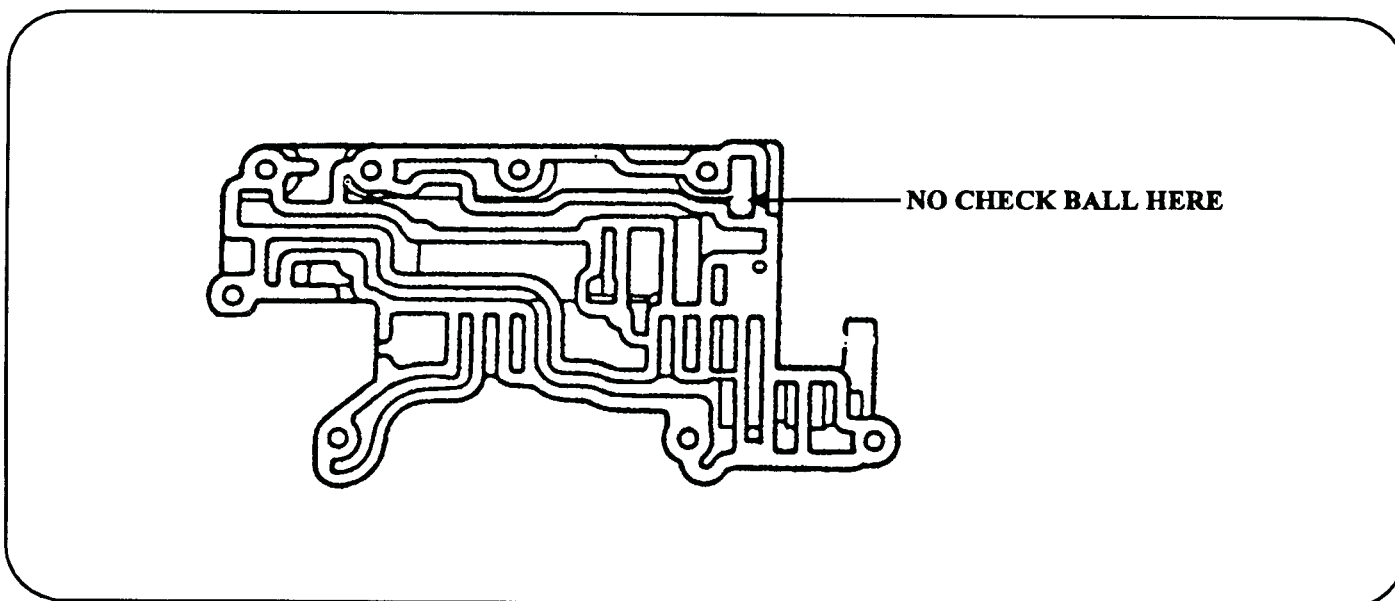
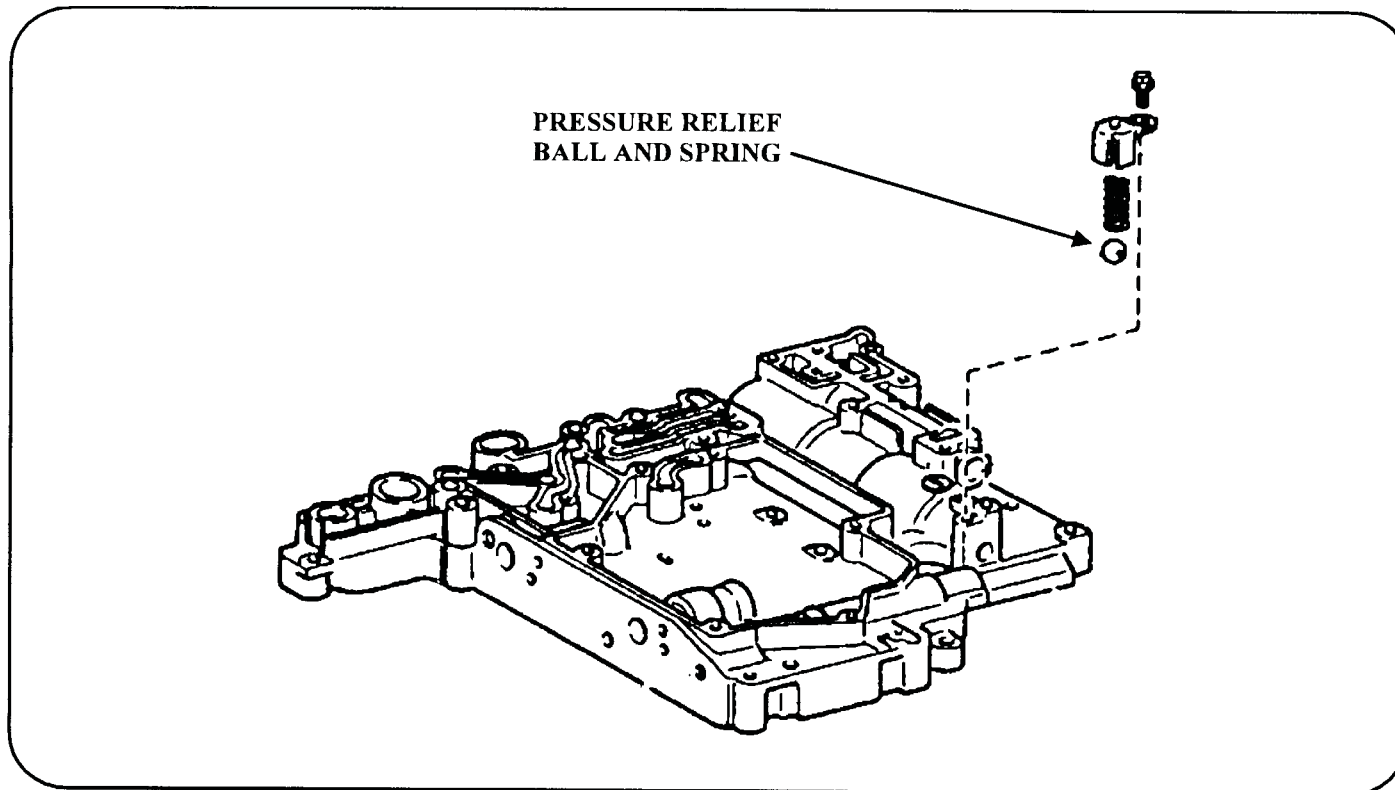

AUTOMATIC TRANSMISSION SERVICE GROUP



## Technical Service Information

### TOYOTA A46DE CHECKBALL LOCATION TOYOTA A46DF CHECK BALL LOCATION

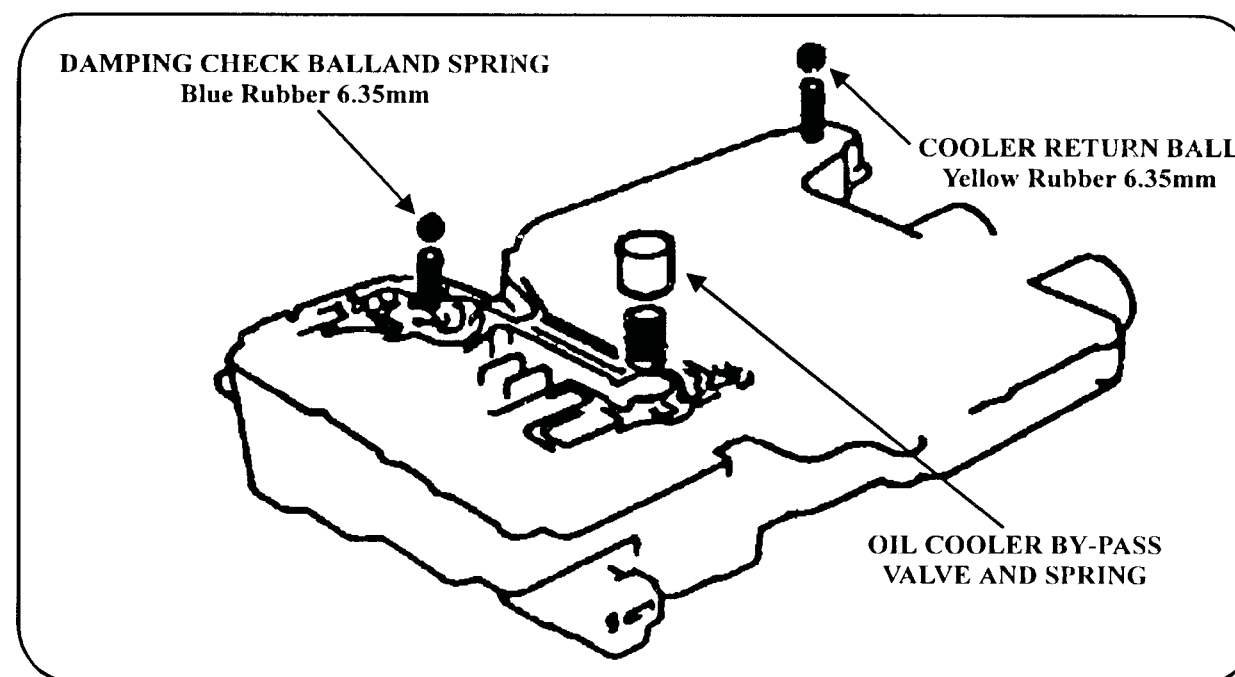
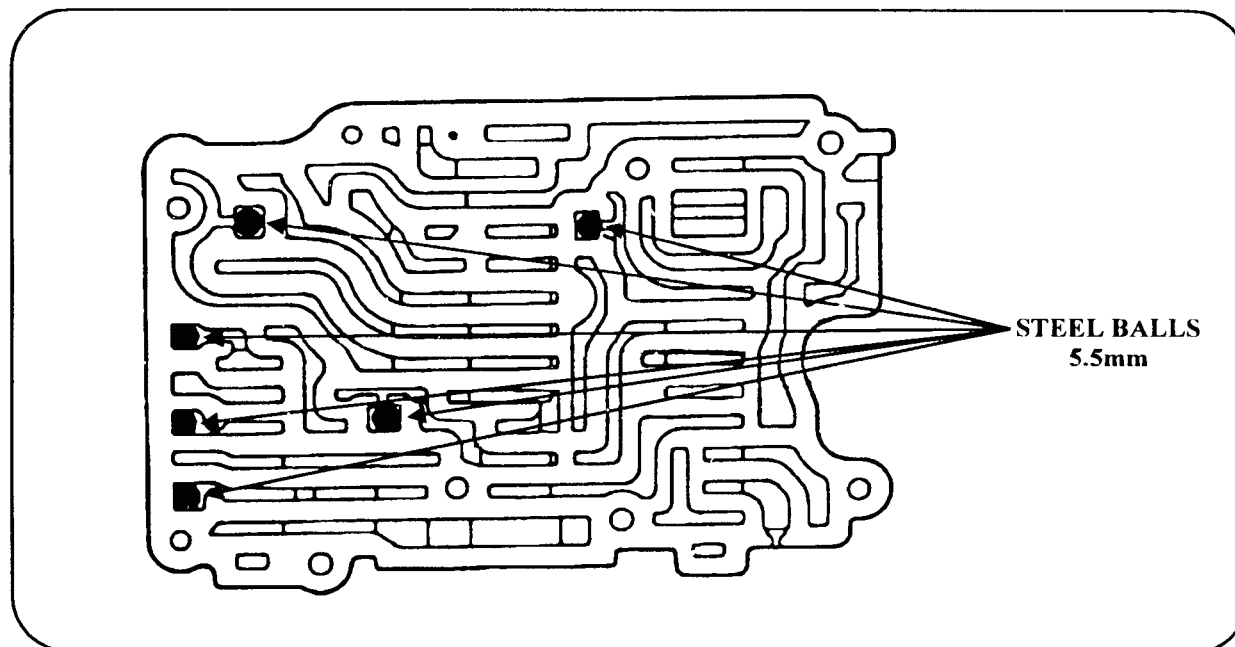

AUTOMATIC TRANSMISSION SERVICE GROUP