

AUTOMATIC TRANSMISSION



SECTION AT

CONTENTS

DESCRIPTION	AT- 2	Final assembly	AT-27
HYDRAULIC CONTROL UNIT AND VALVES	AT- 3	TROUBLE-SHOOTING AND DIAGNOSES	AT-34
HYDRAULIC CONTROL CIRCUIT	AT- 6	Preliminary checks	
LOCK-UP INDICATOR LAMP CIRCUIT	AT- 7	(Prior to road testing)	AT-34
MINOR ADJUSTMENTS	AT- 8	Diagnostic road test	AT-35
REMOVAL AND INSTALLATION	AT-11	Pressure testing	AT-38
Transmission assembly	AT-11	Stall testing	AT-38
MAJOR OVERHAUL OPERATIONS ...	AT-13	Road test symptom chart	AT-44
Service notes for disassembly	AT-14	SERVICE DATA AND SPECIFICATIONS (S.D.S.)	AT-47
Disassembly	AT-14	SPECIAL SERVICE TOOLS	AT-48
Component parts	AT-17		

AT

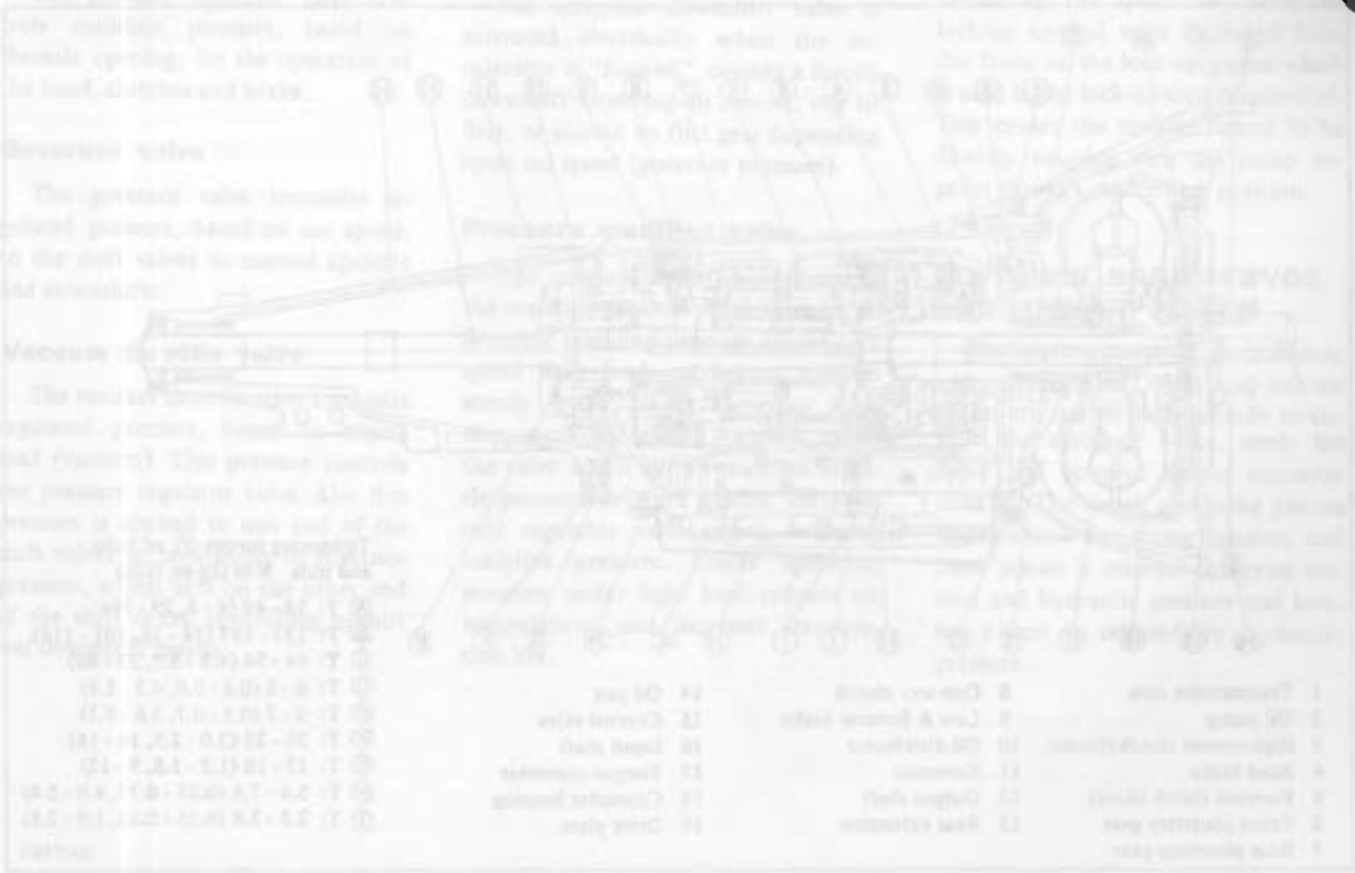

DESCRIPTION

The L3N71B transmission is a fully automatic unit consisting primarily of a 3 element hydraulic lock-up torque converter and two planetary gear sets. Two multiple-disc clutches, a multiple-disc brake, brake band, and one-way clutch provide the friction elements necessary to obtain the desired function of the two planetary gear-sets.

A hydraulic control system is used to operate the friction elements and automatic shift controls.

LOCK-UP TORQUE CONVERTER

The lock-up torque converter is attached to the crankshaft through a flexible drive plate and serves to directly couple the turbine runner and pump impeller through the lock-up piston which is controlled by the speed cut valve and lock-up control valve. Heat generated in the torque converter is dissipated by circulating the transmission fluid through an oil-to-water type cooler in the radiator lower tank.

The welded construction of the torque converter prohibits disassembly or service unless highly specialized equipment is available.

FLUID RECOMMENDATION

Use "DEXRON" type automatic transmission fluid only.

IDENTIFICATION NUMBER

Stamped position :

The plate is attached to the right hand side of transmission case.

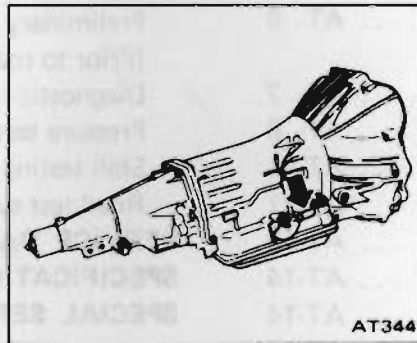

Identification of number arrangements :



Number designation

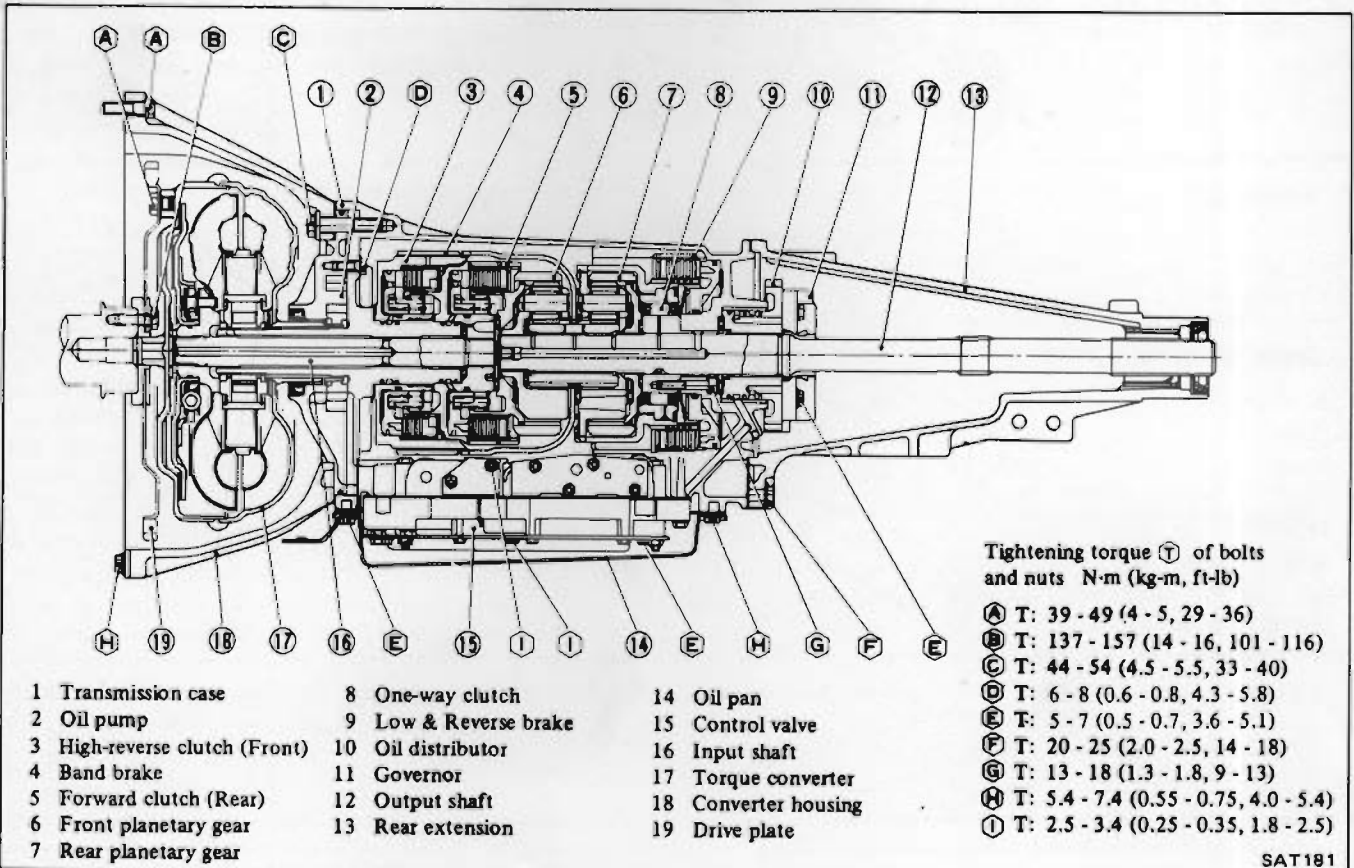
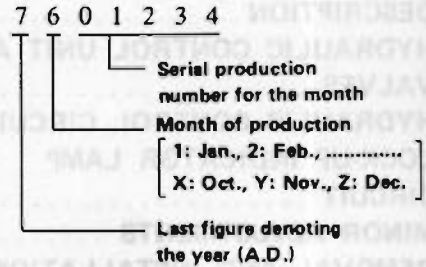

SAT181

HYDRAULIC CONTROL UNIT AND VALVES

The hydraulic, or automatic control system is comprised of four (4) basic groups: the pressure supply system, the pressure regulating system, the flow control valves, and the friction elements.

PRESSURE SUPPLY SYSTEM

The pressure supply system consists of a gear type oil pump driven by the engine through the torque converter. The pump provides pressure for all hydraulic and lubrication needs.

PRESSURE REGULATOR VALVES

The pressure regulating valves control the output pressure of the oil pump.

Pressure regulator valve

The pressure regulator valve controls mainline pressure, based on throttle opening, for the operation of the band, clutches and brake.

Governor valve

The governor valve transmits regulated pressure, based on car speed, to the shift valves to control upshifts and downshifts.

Vacuum throttle valve

The vacuum throttle valve transmits regulated pressure, based on engine load (vacuum). This pressure controls the pressure regulator valve. Also this pressure is applied to one end of the shift valves in opposition to governor pressure, which acts on the other end of the shift valves, controlling upshift and downshift speeds.

FLOW CONTROL VALVES

Manual valve

The manual valve is moved manually by the car operator to select the different drive ranges.

1-2 Shift valve

The 1-2 shift valve automatically shifts the transmission from first to second or from second to first depending upon governor and throttle pressure along with accelerator position (solenoid downshift valve). See Hydraulic Control Circuits, "Drive 2".

2-3 Shift valve

The 2-3 shift valve automatically shifts the transmission from second to top gear or from top to second depending upon governor and throttle pressure, or accelerator position (solenoid downshift valve). See Hydraulic Control Circuits "Drive 3" Range.

Solenoid downshift valve

The solenoid downshift valve is activated electrically when the accelerator is "floored", causing a forced downshift from top to second, top to first, or second to first gear depending upon car speed (governor pressure).

Pressure modified valve

The pressure modifier valve assists the mainline pressure regulator valve in lowering mainline pressure during high speed light load conditions, such as steady speed cruise. Governor pressure, working against a spring, opens the valve which allows modified throttle pressure to work against the pressure regulator valve spring, lowering mainline pressure. Lower operating pressure under light load reduces oil temperature, and increases transmission life.

Throttle back-up valve

The throttle back-up valve assists the vacuum throttle valve to increase line pressure when the manual valve is shifted either to "2" or "1" range.

Second lock valve

The second lock valve is used to bypass the 1-2 shift valve to maintain the band apply pressure in "2" position. The valve is also used as an oil passage for the 1-2 shift valve band apply pressure in "D₂", "D₃" and "1₂" Range.

Speed cut valve

The speed cut valve controls opening and closing of line pressure passage to the high-reverse clutch (Front) in response to governor pressure which is generated in proportion to car speed.

Lock-up control valve

In response to line pressure controlled by the speed cut valve, the lock-up control valve drains oil from the front of the lock-up piston which is used in the lock-up torque converter. This causes the turbine runner to be directly coupled with the pump impeller through the lock-up position.

CLUTCHES, BAND SERVOS AND LOCK-UP PISTON

The servo pistons of the clutches, low reverse brake, band and lock-up piston are moved hydraulically to engage the clutches, brake, apply the band and connect torque converter directly. The clutch and brake pistons are released by spring tension, and band piston is released by spring tension and hydraulic pressure and lock-up piston is released by hydraulic pressure.

HYDRAULIC CONTROL UNIT AND VALVES

Control valve

- 1 Pressure regulating valve
- 2 Manual valve
- 3 1st-2nd shift valve
- 4 2nd-3rd shift valve
- 5 Pressure modifier valve
- 6 Vacuum throttle valve
- 7 Throttle back-up valve
- 8 Solenoid down shift valve
- 9 Second lock valve

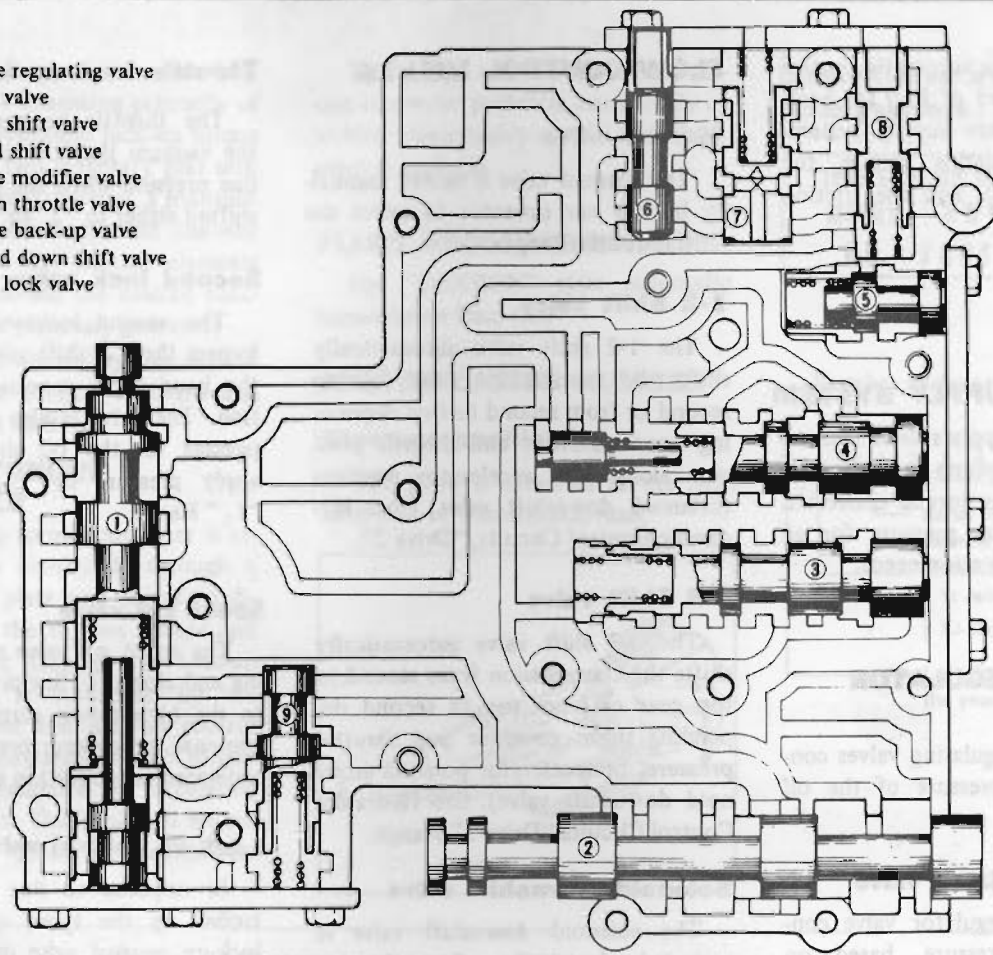

SAT163

Speed cut valve and lock-up control valve (In oil pump cover)

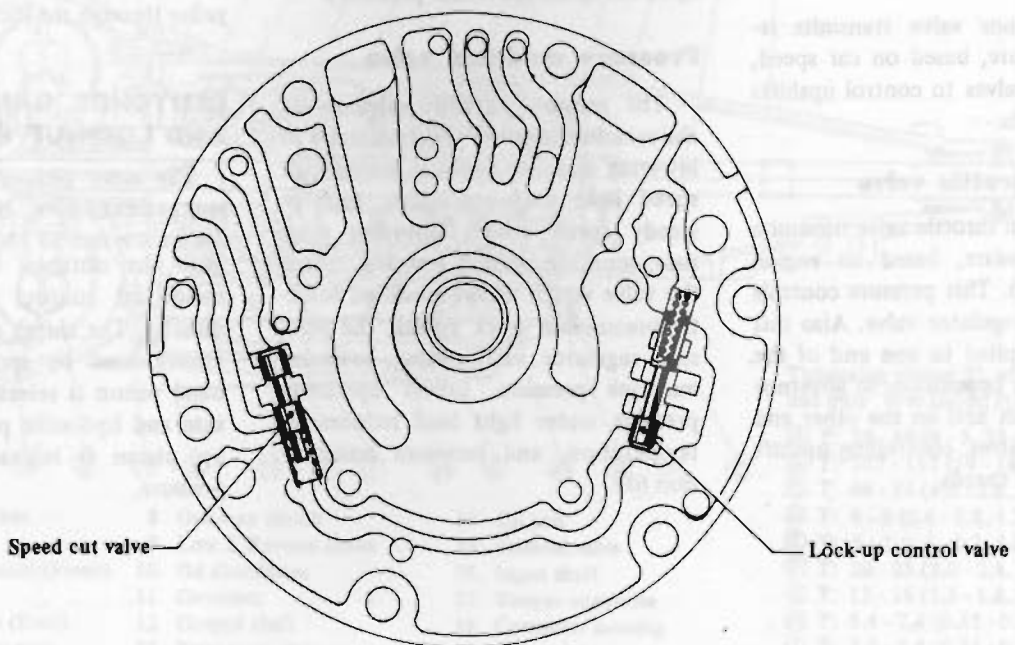

SAT182

HYDRAULIC CONTROL UNIT AND VALVES

OIL CHANNEL IDENTIFICATION

The circuit numbers shown in each Hydraulic Control Circuit are classified as follows according to the function.

Pressure source of the line: 7

Operating line pressure for friction elements:

1, 2, 3, 4, 5, 6, 8, 9, 10, 11, 12.

Auxiliary line pressure: 13

Torque converter pressure: 14

Governor pressure: 15

Throttle system pressure:

16, 17, 18, 19.

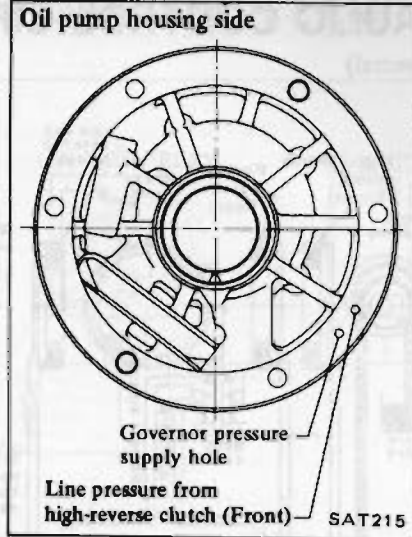

Oil Channels in Case Front Face

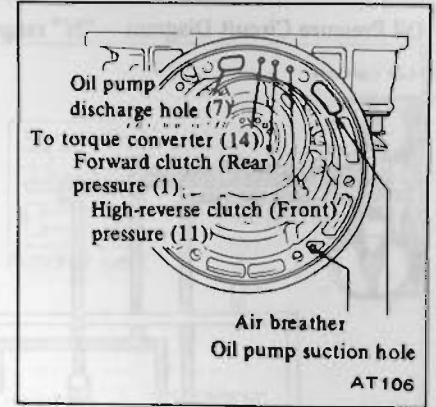

Oil Channels in Oil Pump

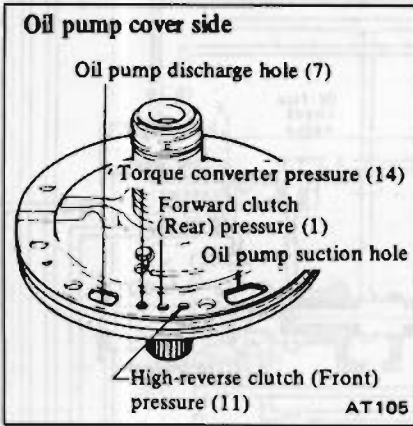

Oil channels in converter housing

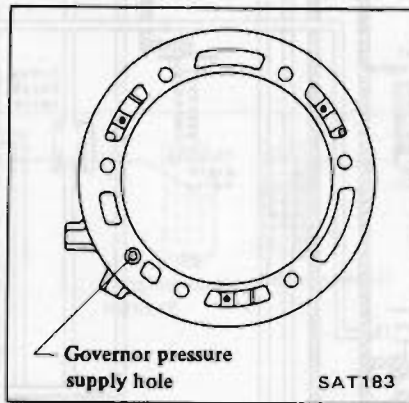

Oil Channels in Case Face

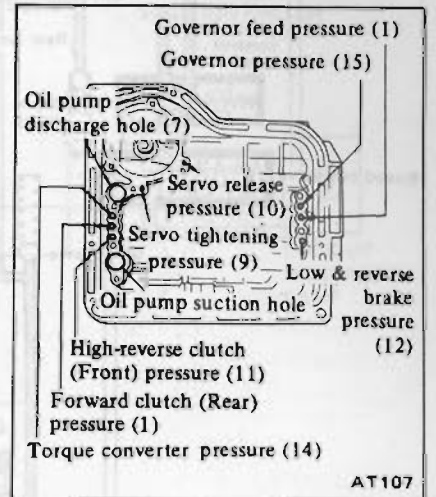

MECHANICAL OPERATION

In the L3N71B automatic transmission, each part operates as shown in the following table at each gear select position.

Range	Gear ratio	Clutch		Low & reverse brake	Lock-up	Band servo		One way clutch	Parking pawl
		High-reverse (Front)	Forward (Rear)			Operation	Release		
Park				on					on
Reverse	2.182	on		on			on		
Neutral									
Drive	D1 Low		on					on	
	D2 Second		on			on			
	D3 Top	1.000	on	on	on	(on)	on		
2	Second		on			on			
1	1 ₂ Second		on			on			
	1 ₁ Low	2.458	on	on					

The low & reverse brake is applied in "1," range to prevent free wheeling when coasting and allows engine braking.

HYDRAULIC CONTROL CIRCUIT

Oil Pressure Circuit Diagram – "N" range (Neutral)

Torque converter

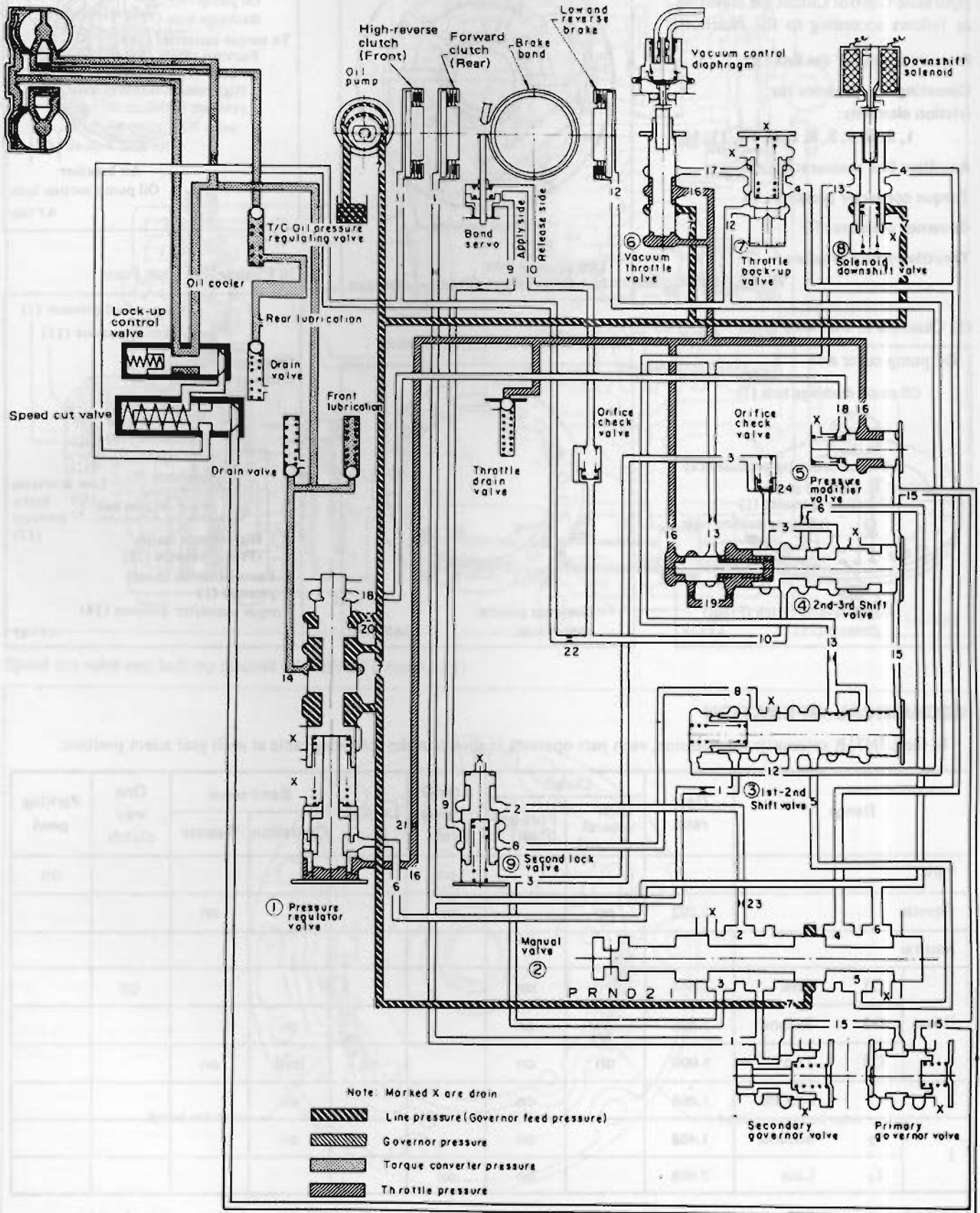

LOCK-UP INDICATOR LAMP CIRCUIT

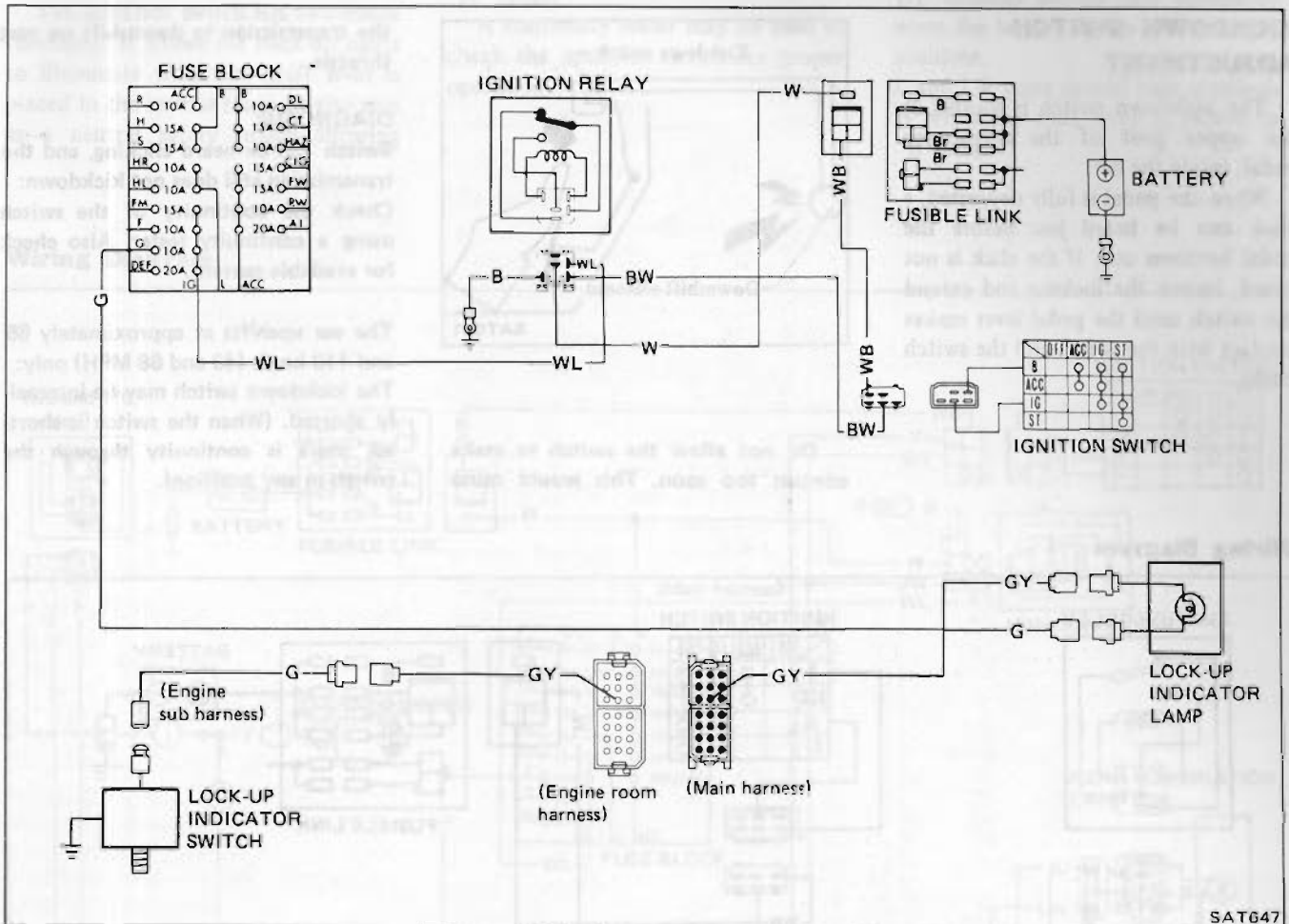

SAT647

MINOR ADJUSTMENTS

KICKDOWN SWITCH ADJUSTMENT

The kickdown switch is located at the upper post of the accelerator pedal, inside the car.

When the pedal is fully depressed, a click can be heard just before the pedal bottoms out. If the click is not heard, loosen the locknut and extend the switch until the pedal lever makes contact with the switch and the switch clicks.

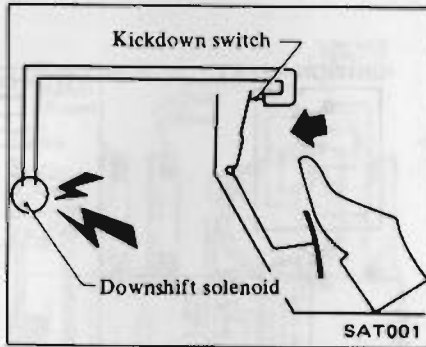

the transmission to downshift on part throttle.

DIAGNOSIS:

Switch can be heard clicking, and the transmission still does not kickdown: Check the continuity of the switch using a continuity tester. Also check for available current.

The car upshifts at approximately 65 and 110 km/h (40 and 68 MPH) only: The kickdown switch may be internally shorted. (When the switch is shorted, there is continuity through the switch in any position).

Do not allow the switch to make contact too soon. This would cause

Wiring Diagram

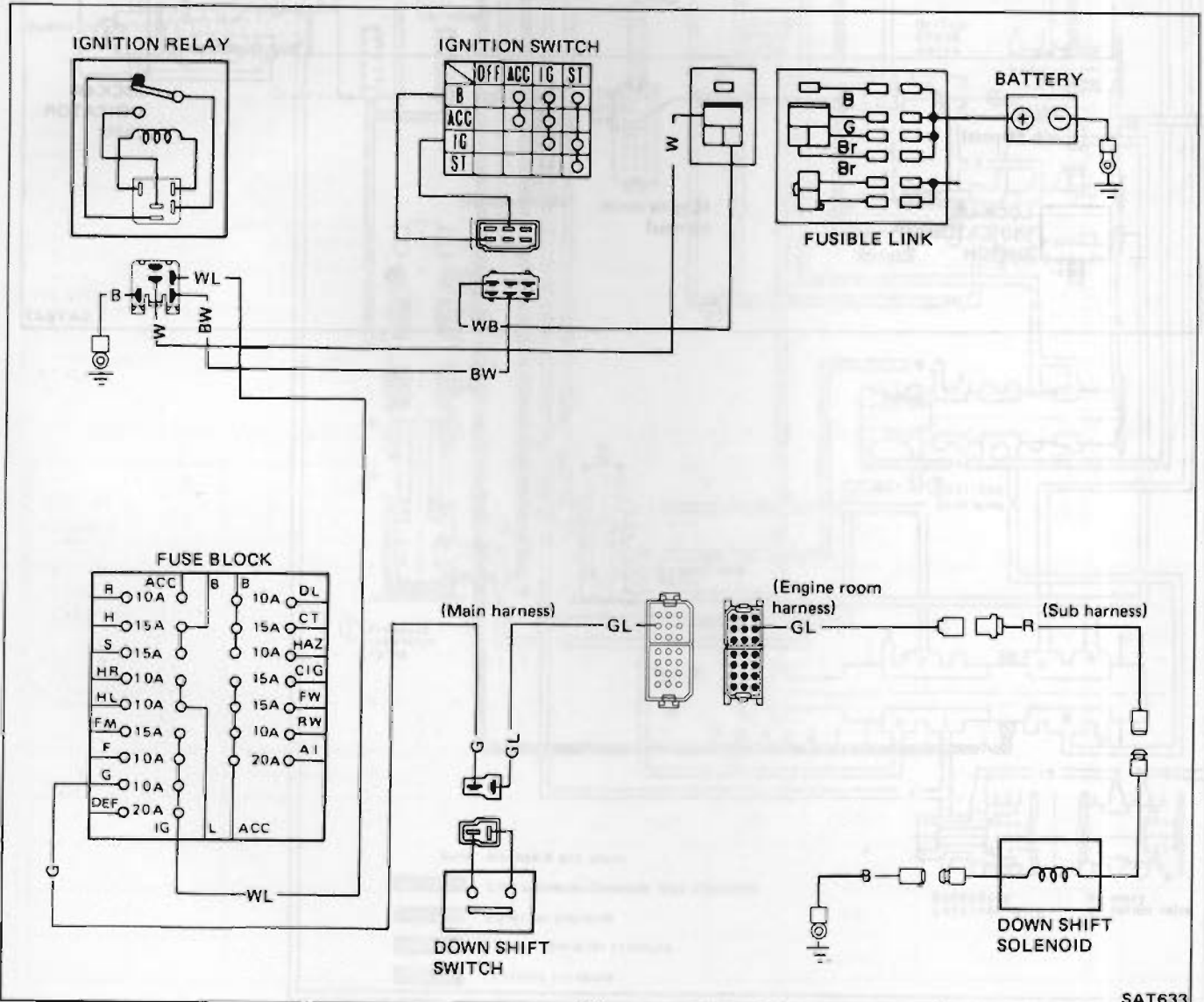

MINOR ADJUSTMENTS

INHIBITOR SWITCH ADJUSTMENT

The inhibitor switch has two major functions. It allows the back-up lights to illuminate when the shift lever is placed in the reverse range. It also acts as a neutral safety switch allowing

current to pass from the starter only when the lever is placed in the "P" or "N" range.

A continuity tester may be used to check the inhibitor switch for proper operation.

GL and B wires (GL and T/C models) and Y and Y wires (Except GL and T/C models) should have continuity when the lever is in the "P" and "N" positions.

L and LW wires should have continuity when the shift lever is moved to "R" range.

Wiring Diagram

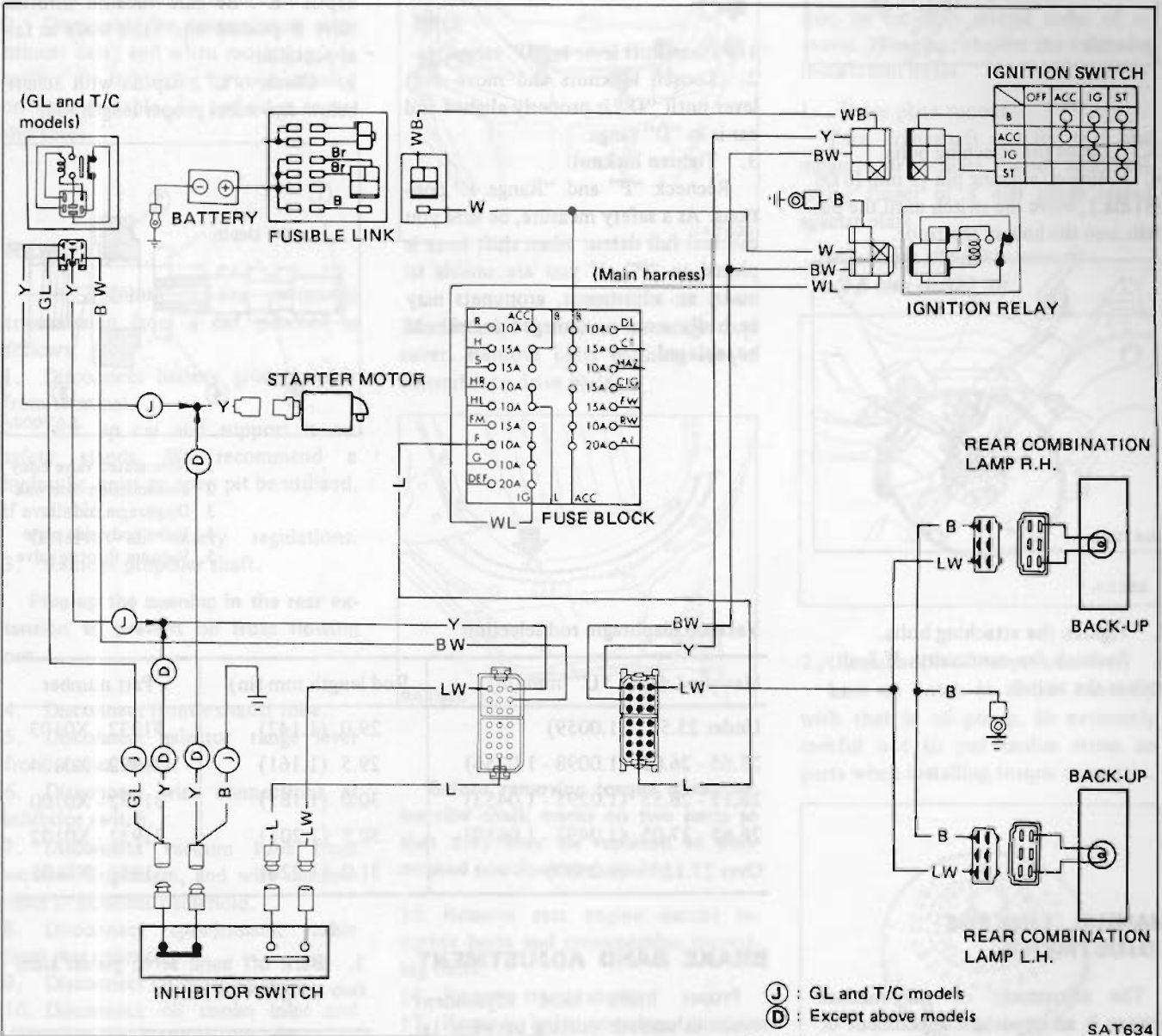

MINOR ADJUSTMENTS

1. Place the manual valve in Neutral (vertical position).
2. Remove the screw as illustrated.

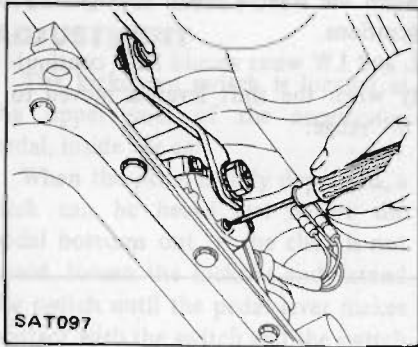

3. Loosen the attaching bolts.
4. Using an aligning pin [2 mm (0.08 in) dia.], move the switch until the pin falls into the hole in the rotor.

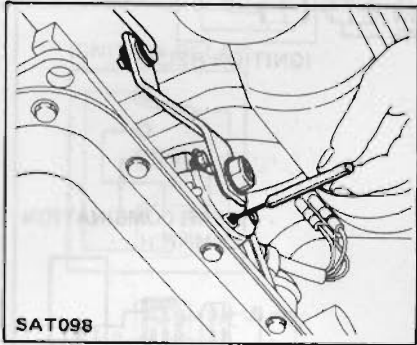

5. Tighten the attaching bolts.
6. Recheck for continuity. If faulty, replace the switch.

MANUAL LINKAGE ADJUSTMENT

The adjustment of the manual linkage is an important adjustment of the automatic transmission. Move the shift lever from the "P" range to "Range 1", you should be able to feel the detents in each range.

If the detents cannot be felt or the pointer indicating the range is improperly aligned, the linkage needs adjustment.

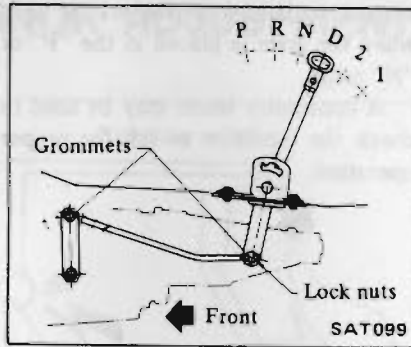

1. Place shift lever in "D" range.
2. Loosen locknuts and move shift lever until "D" is properly aligned and car is in "D" range.
3. Tighten locknut.

Recheck "P" and "Range 1" positions. As a safety measure, be sure you can feel full detent when shift lever is placed in "P". If you are unable to make an adjustment, grommets may be badly worn or damaged and should be replaced.

VACUUM DIAPHRAGM ROD ADJUSTMENT

The vacuum diaphragm and the length of its diaphragm rod help determine the shift patterns of the transmission. It is essential that the correct length rod be installed.

1. Disconnect vacuum hose at vacuum diaphragm and remove diaphragm from transmission case.
2. Using a depth gauge, measure depth "L". Be sure vacuum throttle valve is pushed into valve body as far as possible.
3. Check "L" depth with chart below and select proper length rod.

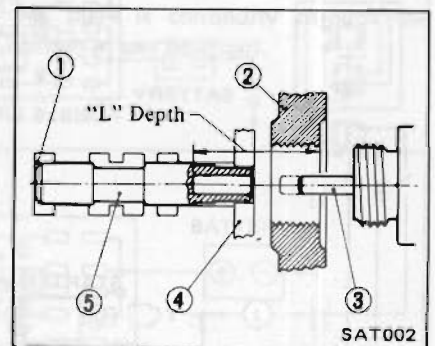

- 1 Note seated valve body
- 2 Transmission case wall
- 3 Diaphragm rod
- 4 Valve body side plate
- 5 Vacuum throttle valve

Vacuum diaphragm rod selection

Measured depth "L" mm (in)	Rod length mm (in)	Part number
Under 25.55 (1.0059)	29.0 (1.142)	31932 - X0103
25.65 - 26.05 (1.0098 - 1.0256)	29.5 (1.161)	31932 - X0104
26.15 - 26.55 (1.0295 - 1.0453)	30.0 (1.181)	31932 - X0100
26.65 - 27.05 (1.0492 - 1.0650)	30.5 (1.201)	31932 - X0102
Over 27.15 (1.0689)	31.0 (1.220)	31932 - X0101

BRAKE BAND ADJUSTMENT

Proper brake band adjustment results in smooth shifting between 1st & 2nd and 2nd & 3rd. Although the adjustment is very simple, it is important to use an accurate torque wrench.

1. Loosen locknut.
2. Torque band servo piston stem to 12 to 15 N·m (1.2 to 1.5 kg-m, 9 to 11 ft-lb).

3. Back off band servo piston stem two complete turns.

CAUTION:

Do not back off EXCESSIVELY on adjusting stem as anchor block may fall out of place.

4. Tighten locknut to approximately 20 N·m (2 kg-m, 14 ft-lb) while holding band servo piston stem stationary.

REMOVAL AND INSTALLATION

TRANSMISSION ASSEMBLY

When dismantling the automatic transmission from a car, pay attention to the following points:

1. Before dismantling the transmission, rigidly inspect it by using the "Trouble-shooting Chart", and dismount it only when it is necessary.
2. Dismount the transmission with utmost care; and when mounting, observing the tightening torque indicated on another table, do not exert excessive force.

REMOVAL

In dismantling the automatic transmission from a car, proceed as follows:

1. Disconnect battery ground cable from terminal.
2. Jack up car and support it on safety stands. We recommend a hydraulic hoist or open pit be utilized, if available.

Observe all safety regulations.

3. Remove propeller shaft.

Plug up the opening in the rear extension to prevent oil from flowing out.

4. Disconnect front exhaust tube.
5. Disconnect selector range lever from manual shaft.
6. Disconnect wire connections at inhibitor switch.
7. Disconnect vacuum tube from vacuum diaphragm, and wire connections at downshift solenoid.
8. Disconnect speedometer cable from rear extension.
9. Disconnect oil charging pipe.
10. Disconnect oil cooler inlet and outlet tubes at transmission case.
11. Disconnect governor tube at converter housing and transmission case.
12. Support engine by locating a jack under oil pan with a wooden block used between oil pan and jack. Support transmission by means of a transmission jack.

CAUTION:

Do not place the jack under the oil pan drain plug.

13. Remove gussets.

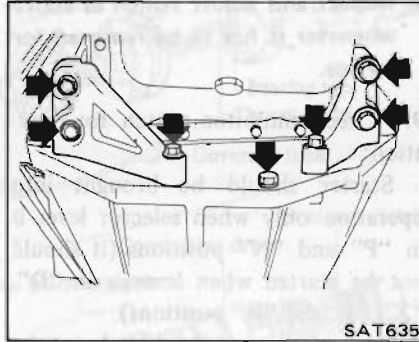

14. Detach converter housing dust cover. Remove bolts securing torque converter to drive plate.

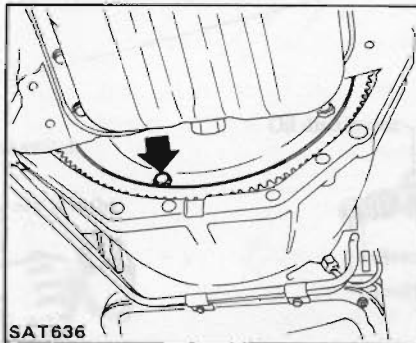

Before removing torque converter, inscribe chalk marks on two parts so that they may be replaced in their original positions at assembly.

15. Remove rear engine mount securing bolts and crossmember mounting bolts.
16. Remove starter motor.
17. Remove bolts securing transmission to engine. After removing these bolts, support engine and transmission with jack, and lower the jack gradually until transmission can be removed and take out transmission under the car.

Plug up openings such as oil charging pipe, oil cooler tubes, etc.

CAUTION:

Take care when dismantling transmission not to strike any adjacent parts.

INSTALLATION

Installation of automatic transmission on car is in reverse order of removal. However, observe the following installation notes.

1. Drive plate runout

Turn crankshaft one full turn and measure drive plate runout with indicating finger of a dial gauge rested against plate.

**Maximum allowable runout:
0.5 mm (0.020 in)**

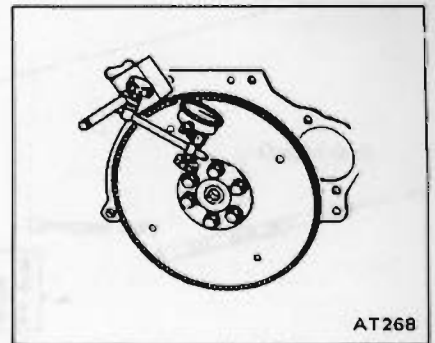

2. Installation of torque converter

Line up notch in torque converter with that in oil pump. Be extremely careful not to put undue stress on parts when installing torque converter.

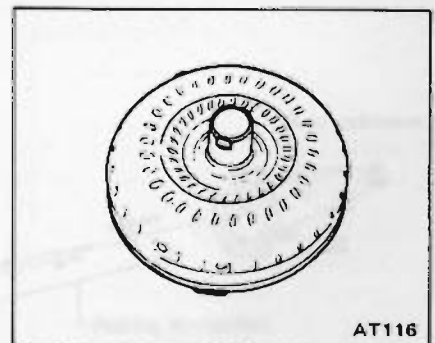

3. When connecting torque converter to transmission, measure distance "A" to be certain that they are correctly assembled.

Distance "A":
More than 35.0 mm (1.378 in)

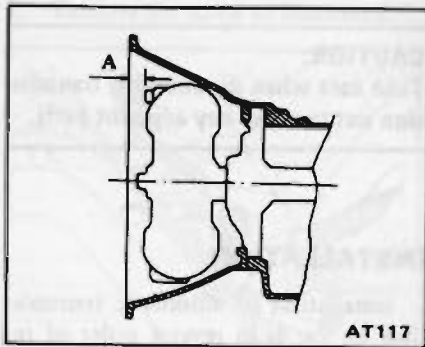

4. Bolt converter to drive plate.

Align chalk marks painted across both parts during disassembling processes.

5. After converter is installed, rotate crankshaft several turns and check to be sure that transmission rotates freely without binding.

6. Pour recommended automatic transmission fluid up to correct level through oil charge pipe.

7. Connect manual lever to shift rod. Operation should be carried out with manual and selector levers in "N".

8. Connect inhibitor switch wires.

a. Refer to pages AT-9 and 10 for Inhibitor Switch Adjustment.

b. Inspect and adjust switch as above whenever it has to be removed for service.

9. Check inhibitor switch for operation:

Starter should be brought into operation only when selector lever is in "P" and "N" positions (it should not be started when lever is in "D", "2", "1" and "R" positions).

Back-up lamp should also light when selector lever is placed in "R" position.

10. Check fluid level in transmission. For detailed procedure, see page AT-34.

11. Move selector lever through all positions to be sure that transmission operates correctly.

With hand brake applied, rotate engine at idling. Without disturbing the above setting, move selector lever through "N" to "D", to "2", to "1" and to "R". A slight shock should be felt by hand gripping selector each time transmission is shifted.

Refer to MA for Checking Engine Idle.

12. Check to be sure that line pressure is correct. To do this, refer to page AT-38 for Line Pressure Test.

13. Perform stall test as described in page AT-38.

MAJOR OVERHAUL OPERATIONS

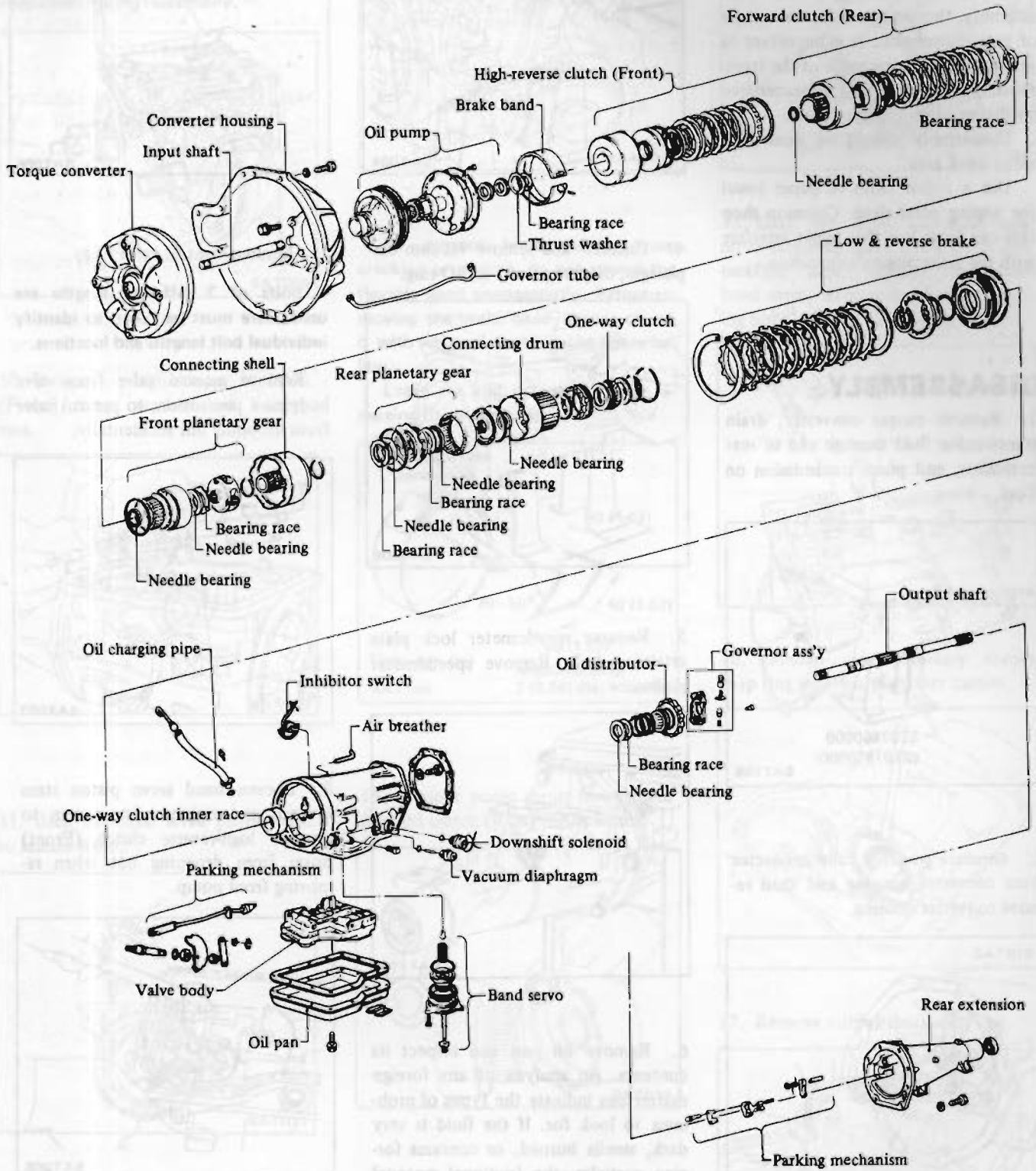

SERVICE NOTES FOR DISASSEMBLY

Before proceeding with disassembly, thoroughly clean the outside of the transmission. It is important to prevent the internal parts of the transmission from becoming contaminated by dirt or other foreign matter.

Disassembly should be done in a clean work area.

Use a nylon cloth or paper towel for wiping parts clean. Common shop rags can leave lint that might interfere with the transmission's operation.

DISASSEMBLY

1. Remove torque converter, drain transmission fluid through end of rear extension, and place transmission on Tool.

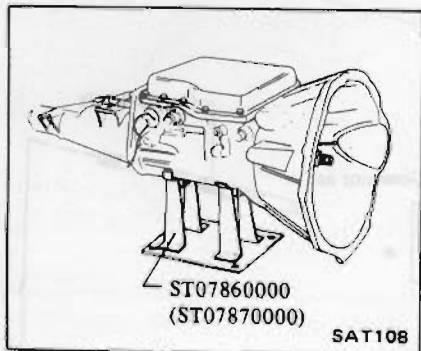

2. Separate governor tube connector from converter housing and then remove converter housing.

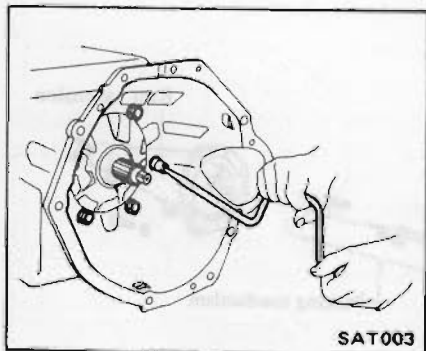

3. Unscrew and remove downshift solenoid and O-ring.

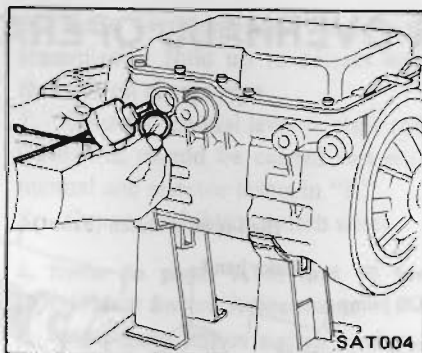

4. Unscrew and remove vacuum diaphragm, diaphragm rod and O-ring.

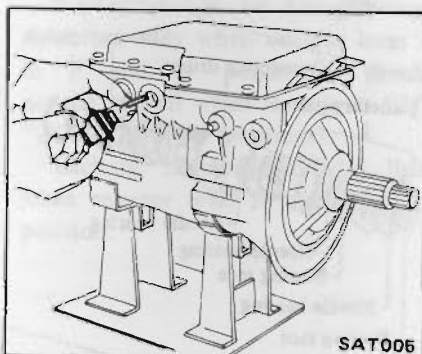

5. Remove speedometer lock plate retaining bolt. Remove speedometer pinion.

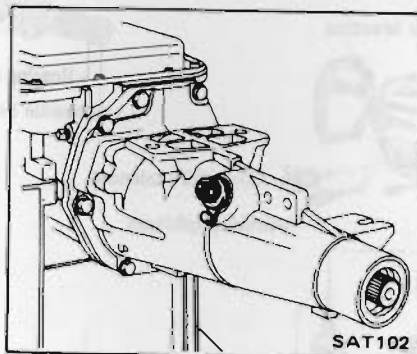

6. Remove oil pan and inspect its contents. An analysis of any foreign matter can indicate the types of problems to look for. If the fluid is very dark, smells burned, or contains foreign particles, the frictional material (clutches, band) may need replacement. A tacky film that will not wipe clean indicates varnish build up which can cause valves, servo, and clutches to stick and may inhibit pump pressure.

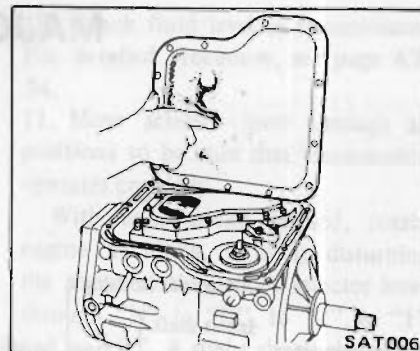

7. Remove control valve body.

Bolts of 3 different lengths are used. Care must be taken to identify individual bolt lengths and locations.

Remove manual valve from valve body as a precaution, to prevent valve from dropping out accidentally.

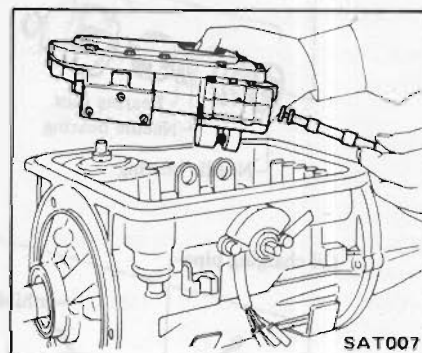

8. Loosen band servo piston stem locknut and tighten piston stem to prevent high-reverse clutch (Front) drum from dropping out when removing front pump.

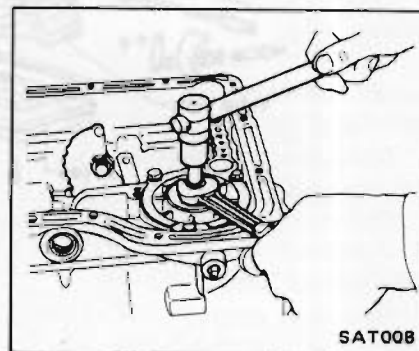

9. Remove input shaft from pump.

Attach Tool to pump and remove pump. Do not allow high-reverse

clutch (Front) to clutch to come out of position and drop onto floor.

Take care that shaft is not inserted backwards during reassembly.

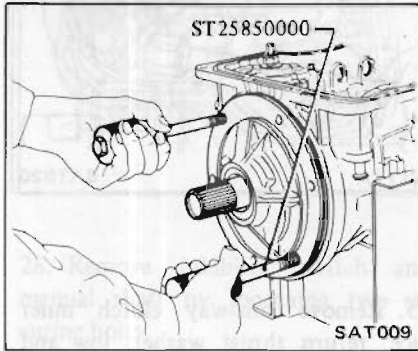

SAT009

10. Remove high-reverse clutch (Front) thrust washer and bearing race.

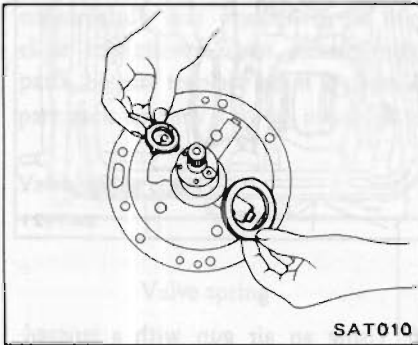

SAT010

11. Back off band servo piston stem to release band.

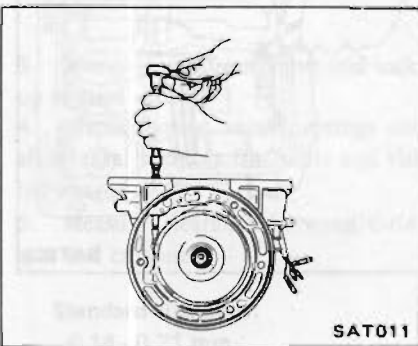

SAT011

12. Remove brake band strut. Brake band, high-reverse clutch (Front) and forward clutch (Rear) assemblies may be removed together.

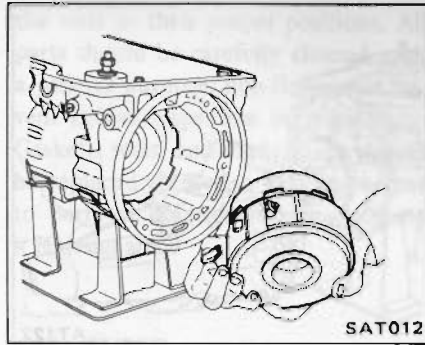

SAT012

To prevent brake linings from cracking or peeling, do not stretch the flexible band unnecessarily. Before removing the brake band, always secure it with a clip as shown in the figure below.

Leave the clip in position after removing the brake band.

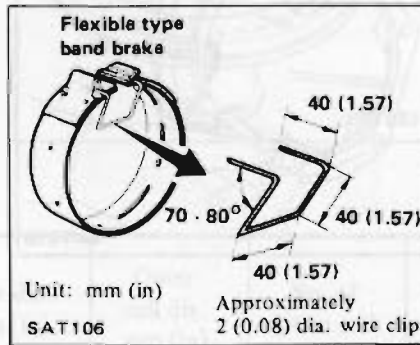

Unit: mm (in)

Approximately

2 (0.08) dia. wire clip

SAT106

13. Remove pump thrust bearing and forward clutch (Rear) thrust washer.

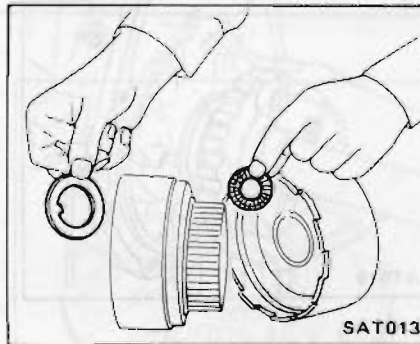

SAT013

14. Remove forward clutch (Rear) hub, front planetary carrier and connecting shell, forward clutch (Rear) thrust bearing, front planetary carrier thrust washer and thrust bearing.

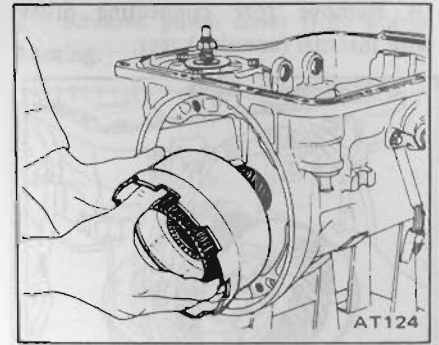

AT124

15. Back out, about half-way, band servo attaching bolts. Using an air gun, carefully apply pressure to loosen band servo. Remove band servo retaining bolts and pull band servo.

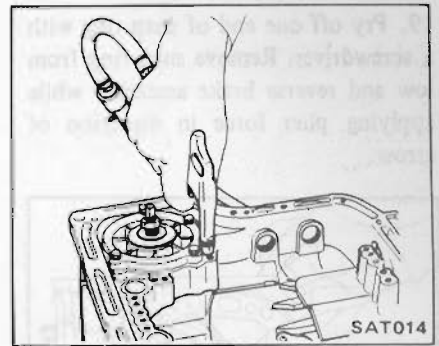

SAT014

16. Remove rear planetary carrier snap ring and rear planetary carrier.

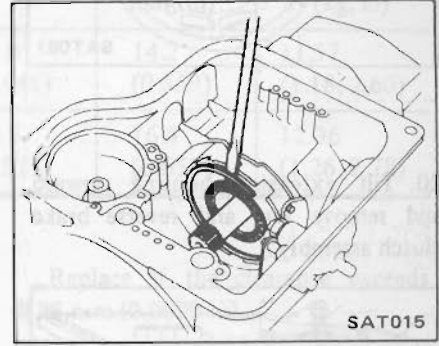

SAT015

17. Remove output shaft snap ring.

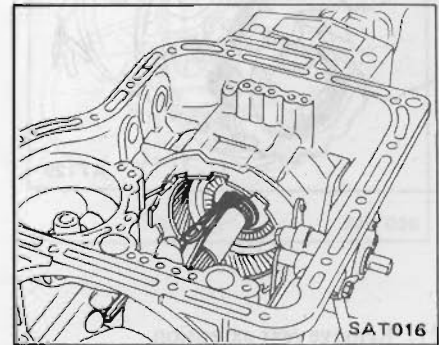

SAT016

MAJOR OVERHAUL OPERATIONS

18. Remove rear connecting drum with internal (annulus) gear.

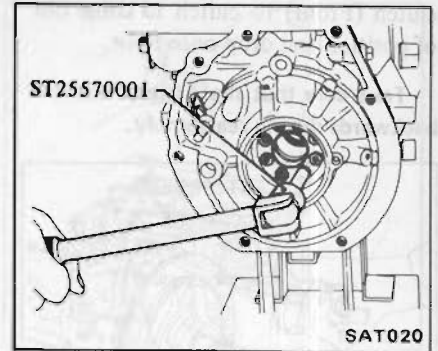
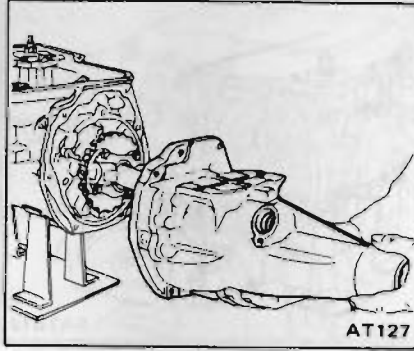
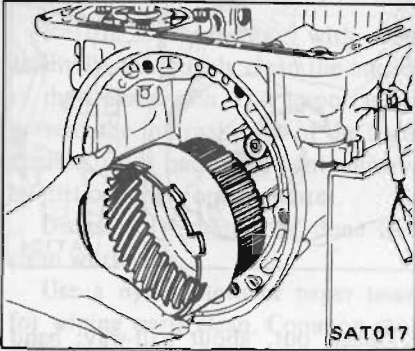

19. Pry off one end of snap ring with a screwdriver. Remove snap ring from low and reverse brake assembly while applying plier force in direction of arrow.

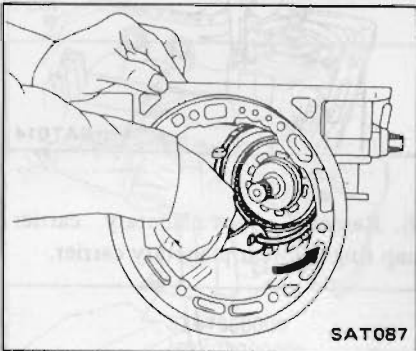

22. Be careful not to lose parking pawl, spring and retainer washer.

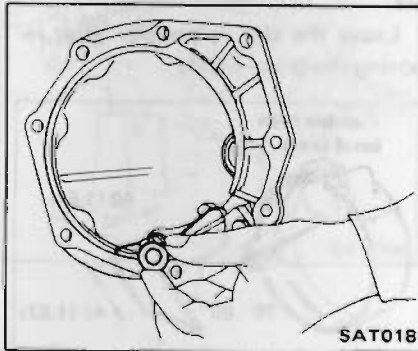

25. Remove one-way clutch inner race, return thrust washer, low and reverse return spring, and spring thrust ring.

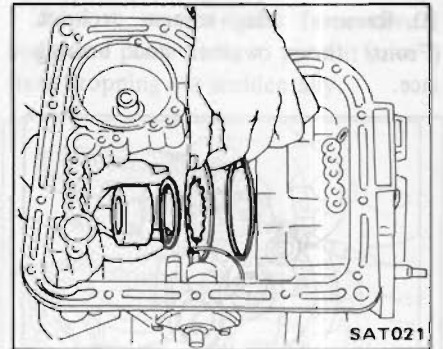

20. Tilt extension housing upward and remove low and reverse brake clutch assembly.

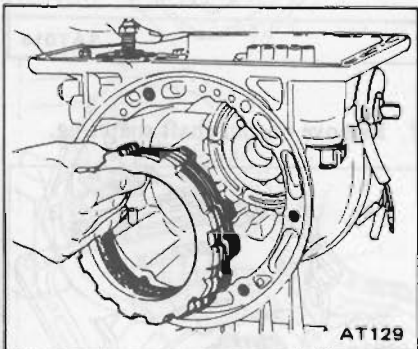

23. Remove output shaft with governor.

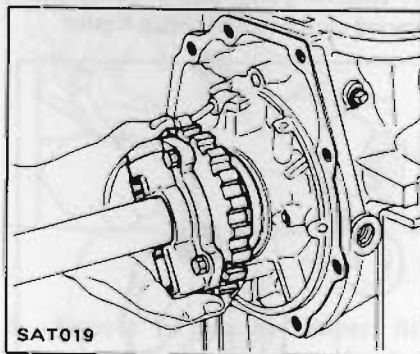

26. Using an air gun with a tapered rubber tip, carefully apply air pressure to remove low and reverse brake piston.

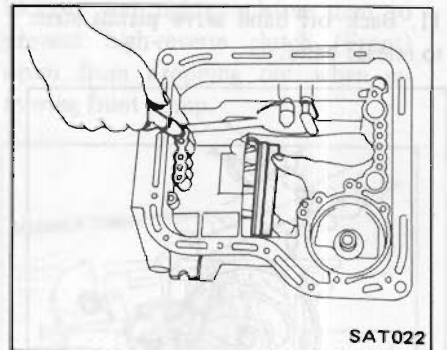

21. Remove rear extension.

24. Remove governor thrust washer and needle bearing.

Remove one-way clutch inner race attaching hex-head slotted bolts using Tool.

27. Pry off snap rings ① from both ends of parking brake lever ② and remove the lever. Back off manual shaft lock nut ③ and remove manual shaft plate ④ and parking rod ⑤.

MAJOR OVERHAUL OPERATIONS

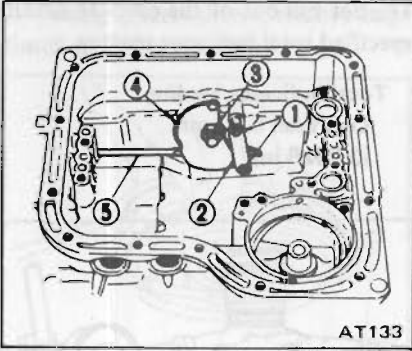

AT133

28. Remove inhibitor switch and manual shaft by loosening two securing bolts.

COMPONENT PARTS

The transmission consists of many small parts that are quite alike in construction yet machined to very close tolerances. When disassembling parts, be sure to place them in order in part rack so they can be put back in

Valve spring chart

Valve spring	Wire dia. mm (in)	Outer coil dia. mm (in)	No. of active coil	Free length mm (in)	Installed	
					Length mm (in)	Load N (kg, lb)
Speed cut valve	0.70 (0.0276)	6.70 (0.2638)	9.5	24.0 (0.945)	14.2 (0.559)	11.57 (1.18, 2.60)
Lock-up control valve	0.65 (0.0256)	4.95 (0.1949)	12.8	23.5 (0.925)	16.5 (0.650)	12.36 (1.26, 2.78)

3. Remove speed cut valve and lock-up control valve.
4. Inspect gears, valves, springs and all internal surfaces for faults and visible wear.
5. Measure clearance between outer gear and crescent.

Standard clearance:
0.14 - 0.21 mm
(0.0055 - 0.0083 in)

Replace if the clearance exceeds
0.25 mm (0.0098 in).

the unit in their proper positions. All parts should be carefully cleaned with a general purpose, non-flammable solvent before inspection or reassembly. Gaskets, seals, and similar parts should be replaced. It is also very important to perform functional tests whenever it is designated.

OIL PUMP

1. Remove front pump gasket and O-ring. Inspect pump body, pump shaft and ring groove areas for wear.

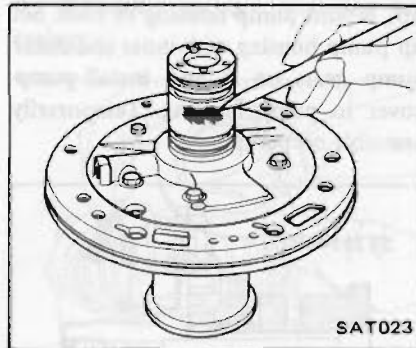

SAT023

2. Remove pump cover from pump housing.

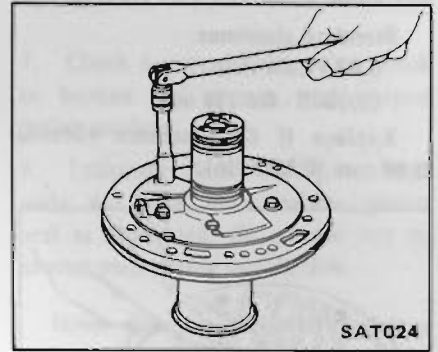

SAT024

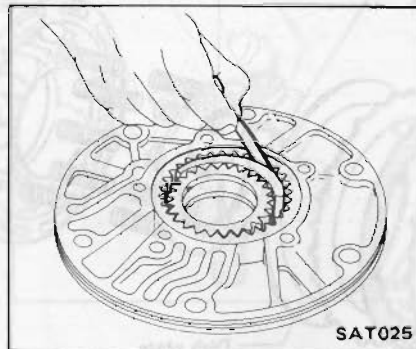

SAT025

6. Measure clearance between outer gear and pump housing.

Standard clearance:
0.05 - 0.20 mm
(0.0020 - 0.0079 in)

Replace if the clearance exceeds
0.25 mm (0.0098 in).

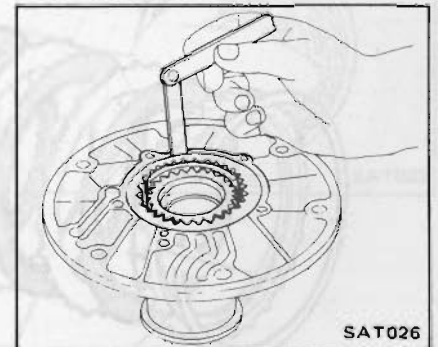

SAT026

7. Using a feeler gauge and straight edge, measure clearance between gears and pump cover.

Standard clearance:
0.02 - 0.04 mm
(0.0008 - 0.0016 in)

Replace if the clearance exceeds 0.08 mm (0.0031 in).

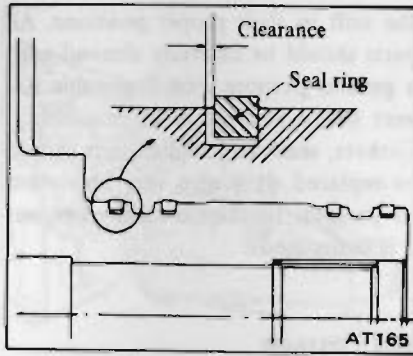
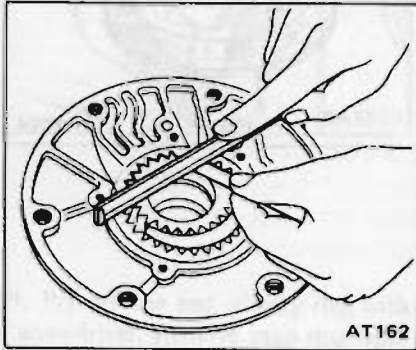

9. Install speed cut valve, lock-up control valve and springs into oil pump cover, then tap retaining pins.

10. Mount pump housing in Tool. Set up pump housing with inner and outer pump gears on it and install pump cover to pump housing. Temporarily assemble oil pump.

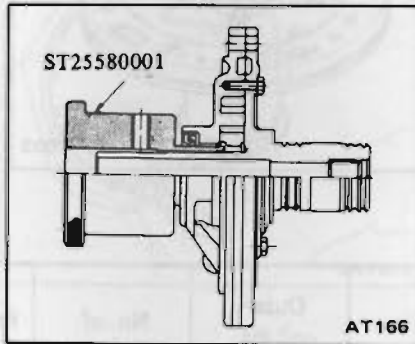

8. Measure clearance between seal ring and ring groove.

Standard clearance:
0.04 - 0.16 mm
(0.0016 - 0.0063 in)

Replace if the clearance exceeds 0.16 mm (0.0063 in).

Of course, it is good practice to replace all seal rings during an overhaul.

11. Set run-out of the cover to within specified total indicator reading.

Total indicator reading:
Less than 0.07 mm
(0.0028 in)

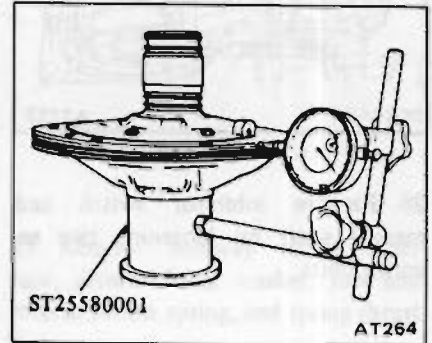

12. Tighten pump securing bolts to specified torque.

⊕ : Oil pump housing to oil pump cover

6 - 8 N·m
(0.6 - 0.8 kg·m,
4.3 - 5.8 ft·lb)

Recheck run-out. Replace O-ring and gasket.

HIGH-REVERSE CLUTCH (Front)

In regard to the number of clutch sheets (drive plate and driven plate), refer to S.D.S.

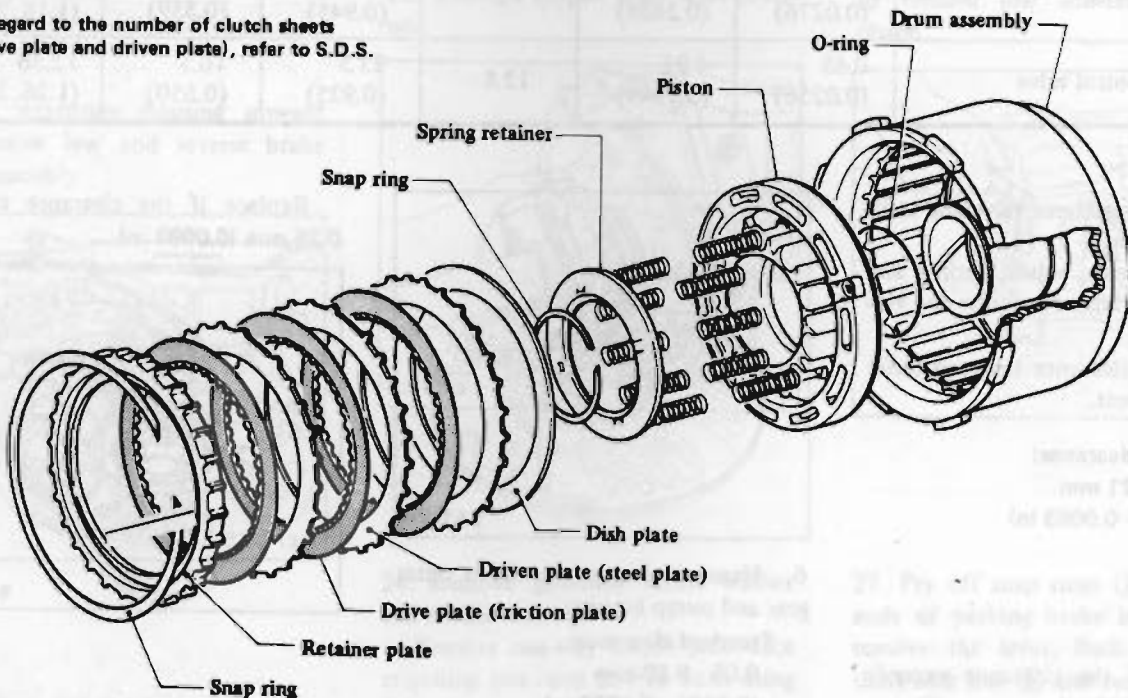

SAT086

MAJOR OVERHAUL OPERATIONS

1. Using a screwdriver, remove large clutch retaining plate snap ring.

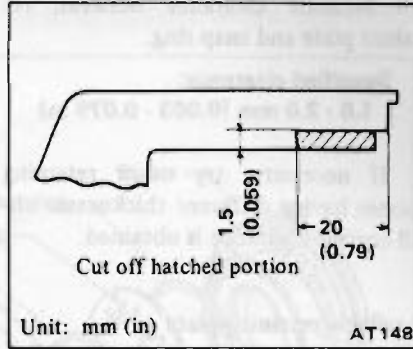
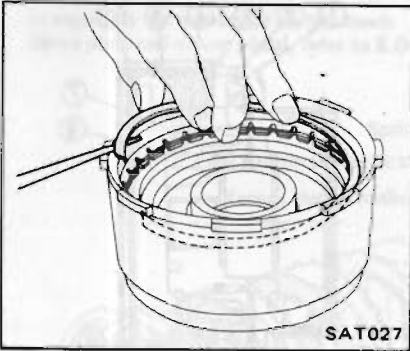

Standard drive plate thickness:

**1.50 - 1.65 mm
(0.0591 - 0.0650 in)**

7. Check for wear on snapping, weak or broken coil springs, and warped spring retainer.

8. Lubricate clutch drum hub and seals, and install inner seal and piston seal as illustrated. *Be careful not to stretch seals during installation.*

Never assemble clutch dry; always lubricate its components thoroughly.

2. Remove clutch plate assembly.

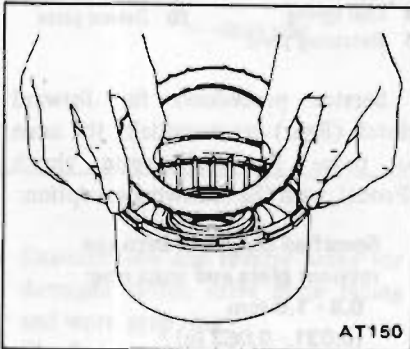

4. Remove spring retainer and springs.

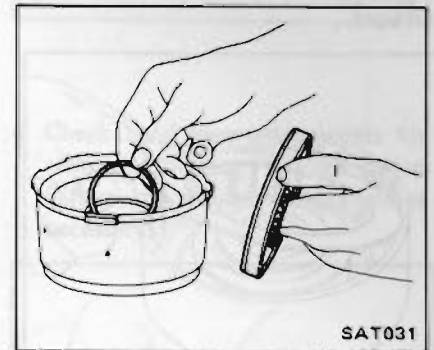
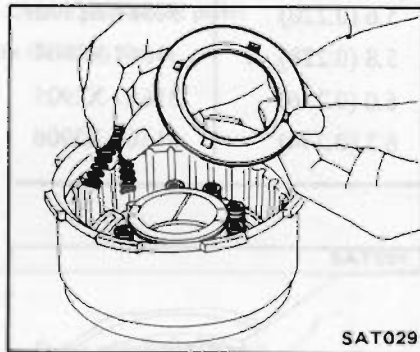

3. Compress clutch springs and remove snap ring from spring retainer.

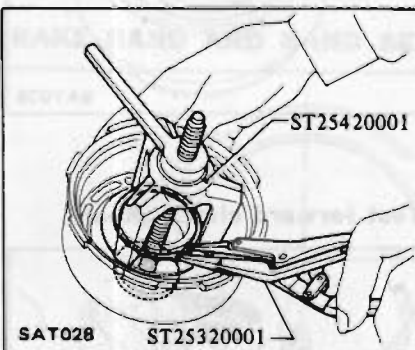

5. For easy removal of piston from drum, mount clutch on pump. Use an air gun with a tapered rubber tip to carefully apply air pressure to loosen piston from drum.

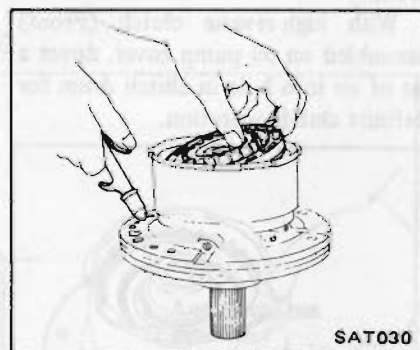

9. Assemble piston, being careful not to allow seal to kink or become damaged during installation. After installing, turn piston by hand to ensure that there is no binding.

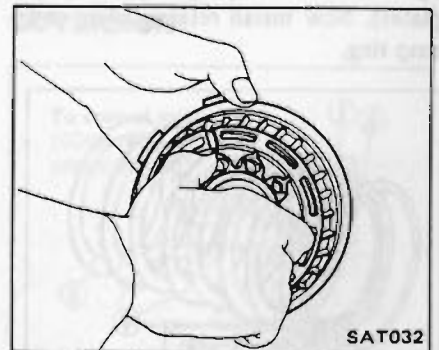

When Tool is to be used, cut toe-tips of three legs with a grinding wheel.

6. Check clutch drive plate facing for wear or damage. Drive plate thickness must not be less than 1.4 mm (0.055 in).

10. Reassemble spring and retainer. Reinstall snap ring. Be sure snap ring is properly seated.

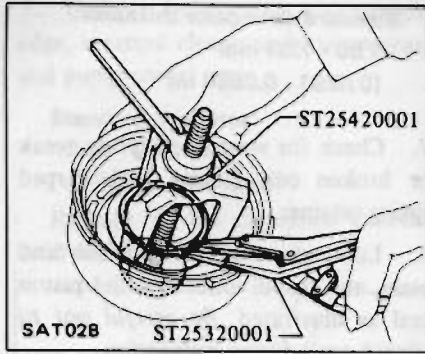

11. Install dish plate with dish facing outward.

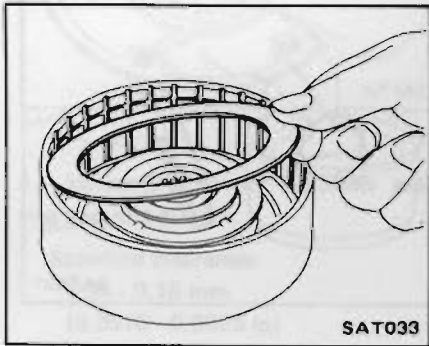

12. Now install driven plate (steel plate), then a drive plate (friction plate) and repeat in this order until correct number of plates has been installed (check Service Data and Specifications for proper quantity of plates). Now install retainer plate and snap ring.

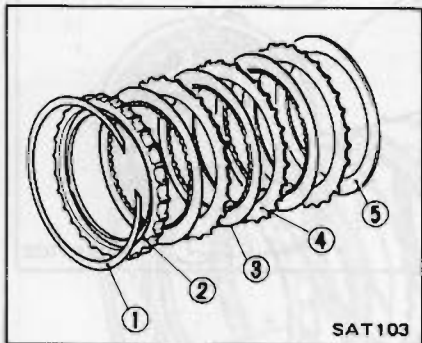

- 1 Snap ring
- 2 Retainer plate
- 3 Drive plate (Friction plate)
- 4 Driven plate (Steel plate)
- 5 Dish plate

13. Measure clearance between retainer plate and snap ring.

Specified clearance:
1.6 - 2.0 mm (0.063 - 0.079 in)

If necessary, try other retaining plates having different thicknesses until correct clearance is obtained.

Available retaining plate

Thickness mm (in)	Part number
5.0 (0.197)	31567-X2900
5.2 (0.205)	31567-X2901
5.4 (0.213)	31567-X2902
5.6 (0.220)	31567-X2903
5.8 (0.228)	31567-X2904
6.0 (0.236)	31567-X2905
6.2 (0.244)	31567-X2906

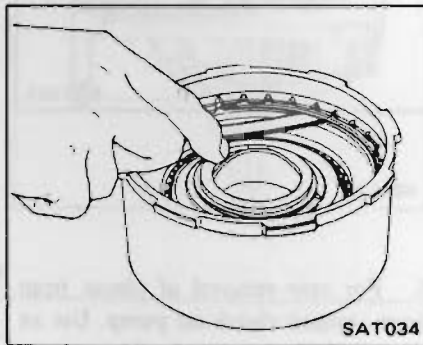

14. Testing high-reverse clutch (Front)

With high-reverse clutch (Front) assembled on oil pump cover, direct a jet of air into hole in clutch drum for definite clutch operation.

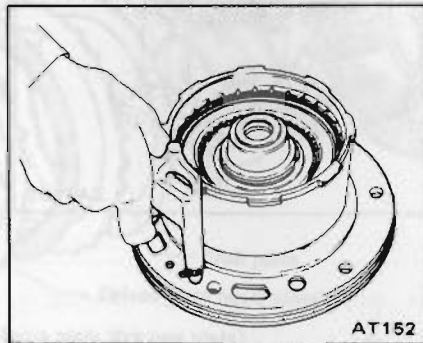

FORWARD CLUTCH (Rear)

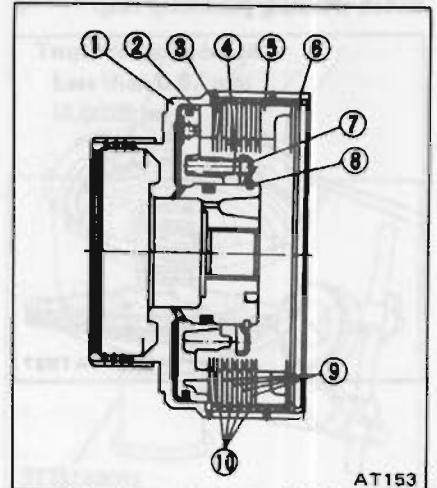

- 1 Forward clutch (Rear) drum
- 2 Piston
- 3 Dished plate
- 4 Coil spring
- 5 Retaining plate
- 6 Snap ring
- 7 Spring retainer
- 8 Snap ring
- 9 Drive plate
- 10 Driven plate

Service procedures for forward clutch (Rear) are essentially the same as those for high-reverse clutch (Front), with the following exception:

Specified clearance between retainer plate and snap ring:
0.8 - 1.6 mm
(0.031 - 0.063 in)

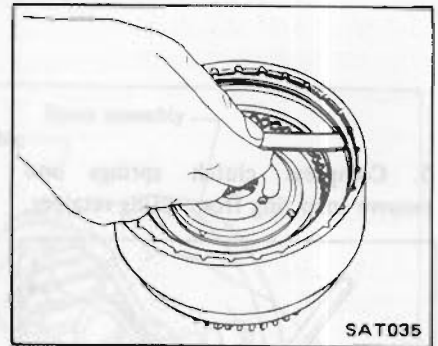

Test forward clutch (Rear)



LOW & REVERSE BRAKE

In regard to the number of clutch sheets (drive plate and driven plate), refer to S.D.S.

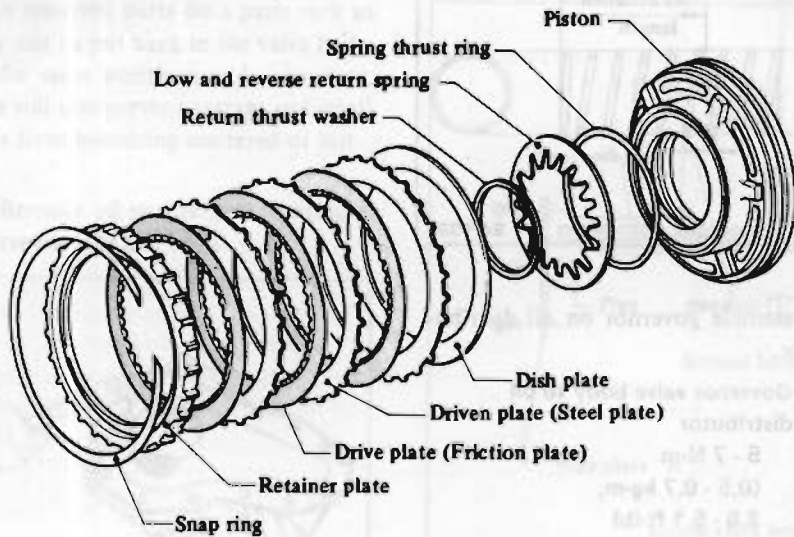

SAT094

- Examine low and reverse brake for damaged clutch drive plate facing and worn snap ring.
- Check drive plate facing for wear or damage; if necessary, replace.

Drive plate thickness:
Standard
 1.90 - 2.05 mm
 (0.0748 - 0.0807 in)
Allowable limit
 1.8 mm (0.071 in)

- Test piston return spring for weakness. Discard if it is too weak.

- Inspect band friction material for wear. If cracked, chipped or burnt spots are apparent, replace the band.

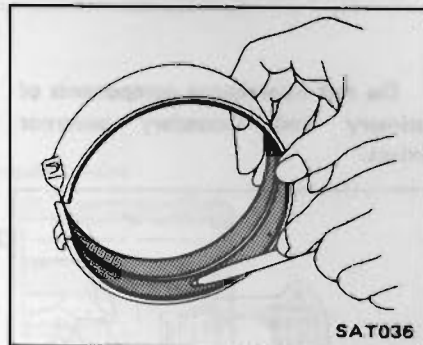

SAT036

- Check band servo components for wear and scoring. Replace piston O-rings and all other components as necessary.

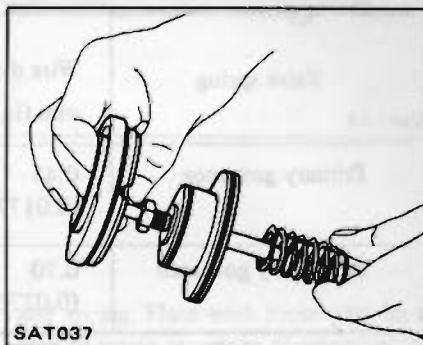

SAT037

BRAKE BAND AND BAND SERVO

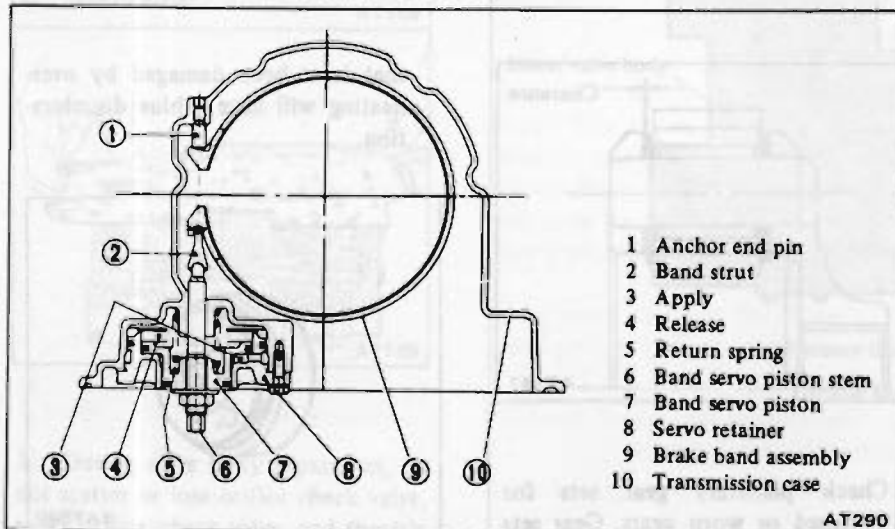

- 1 Anchor end pin
- 2 Band strut
- 3 Apply
- 4 Release
- 5 Return spring
- 6 Band servo piston stem
- 7 Band servo piston
- 8 Servo retainer
- 9 Brake band assembly
- 10 Transmission case

AT290

GOVERNOR

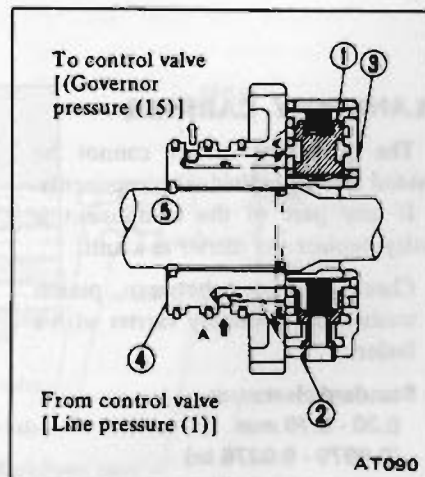

AT090

- 1 Primary governor
- 2 Secondary governor
- 3 Governor valve body
- 4 Oil distributor
- 5 Output shaft

- Disassemble governor and check valves for indication of burning or scratches. Inspect springs for weakness or burning. Replace parts as necessary and reassemble.

Do not interchange components of primary and secondary governor valves.

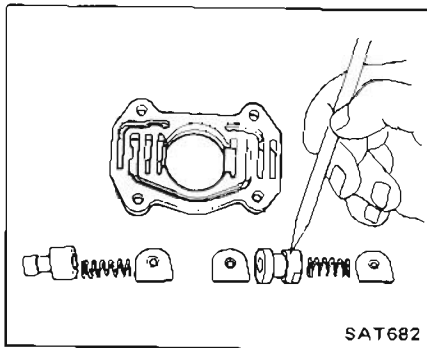

Governor valve spring chart

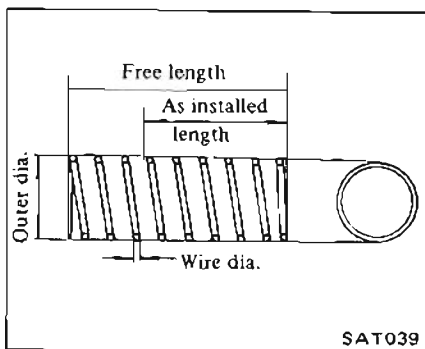

- Assemble governor on oil distributor.

⊕ : Governor valve body to oil distributor
 5 - 7 N-m
 (0.5 - 0.7 kg-m,
 3.6 - 5.1 ft-lb)

Valve spring	Wire dia. mm (in)	Outer coil dia. mm (in)	No. of active coil	Free length mm (in)	Installed	
					Length mm (in)	Load N (kg, lb.)
Primary governor	0.45 (0.0177)	8.75 (0.3445)	5.0	21.8 (0.858)	7.5 (0.295)	2.109 (0.215, 0.474)
Secondary governor	0.70 (0.0276)	9.20 (0.3622)	5.5	25.2 (0.992)	10.5 (0.413)	10.788 (1.100, 2.426)

PLANETARY CARRIER

The planetary carrier cannot be divided into its individual components.

If any part of the component is faulty, replace the carrier as a unit.

- Check clearance between pinion washer and planetary carrier with a feeler.

Standard clearance:
 0.20 - 0.70 mm
 (0.0079 - 0.0276 in)

Replace if the clearance exceeds 0.80 mm (0.0315 in).

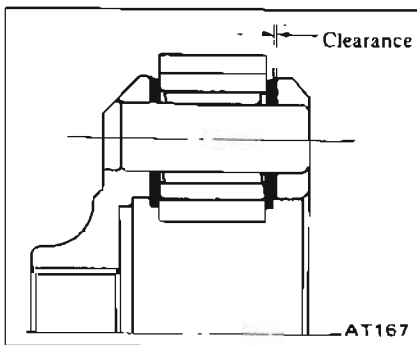

- Check planetary gear sets for damaged or worn gears. Gear sets

that have been damaged by overheating will have a blue discoloration.

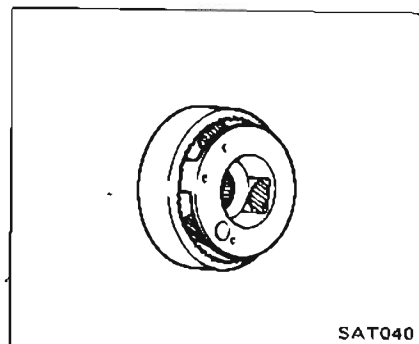

CONTROL VALVE BODY

The valve body contains many precision parts and requires extreme care when parts are removed and serviced. Place removed parts on a parts rack so they can be put back in the valve body in the same positions and sequences. Care will also prevent springs and small parts from becoming scattered or lost.

1. Remove oil strainer and its attaching screws, nuts and bolts.

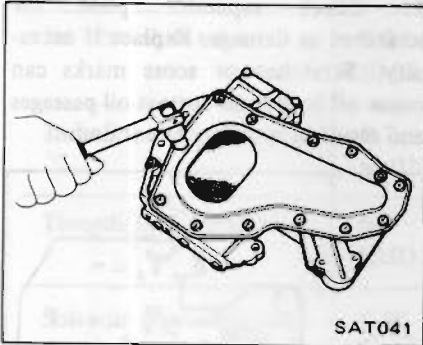

relief check valve (ball) and related springs.

4. Remove side plate A, pressure regulator valve, spring, spring seat,

sleeve, and plug, and second lock valve and spring. Place each loose part on a rack to retain correct sequence of assembly.

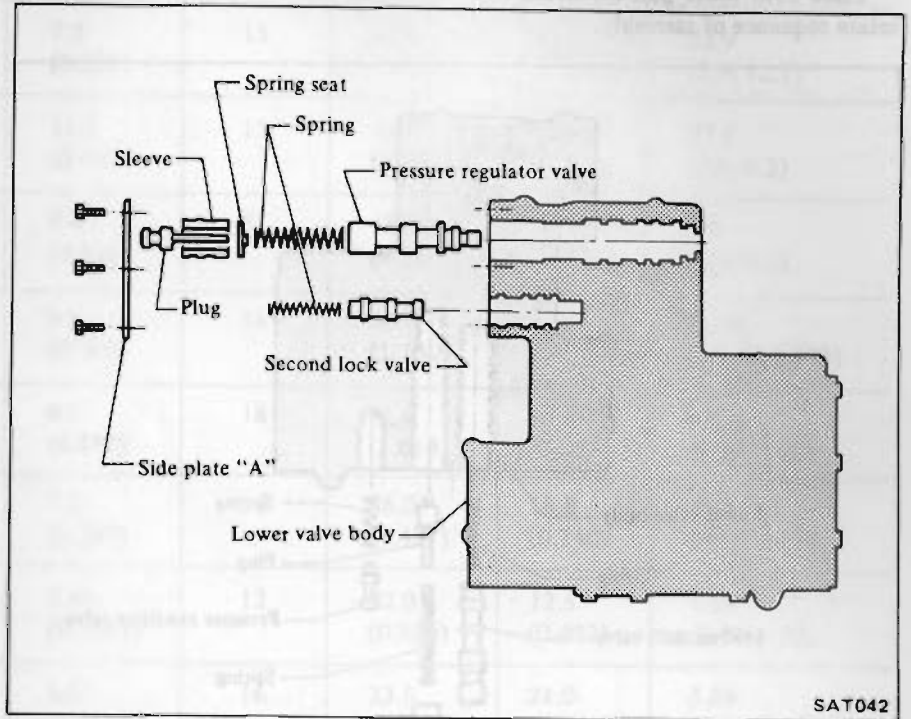

2. Disassemble valve body and its remaining attaching bolts and nuts to carefully separate lower body, separator plate and upper body.

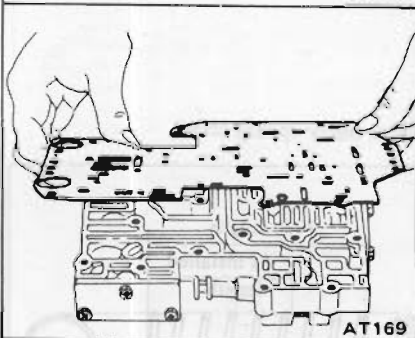
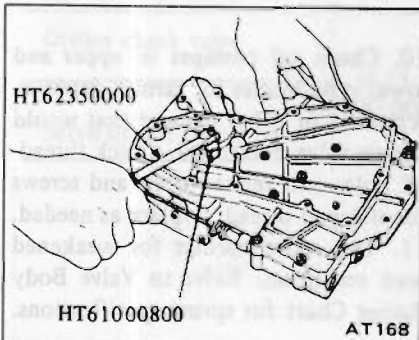

5. Remove side plate B, vacuum throttle valve, throttle back-up valve and spring, and the kickdown valve

and spring. Place each loose part on a rack to retain sequence of assembly.

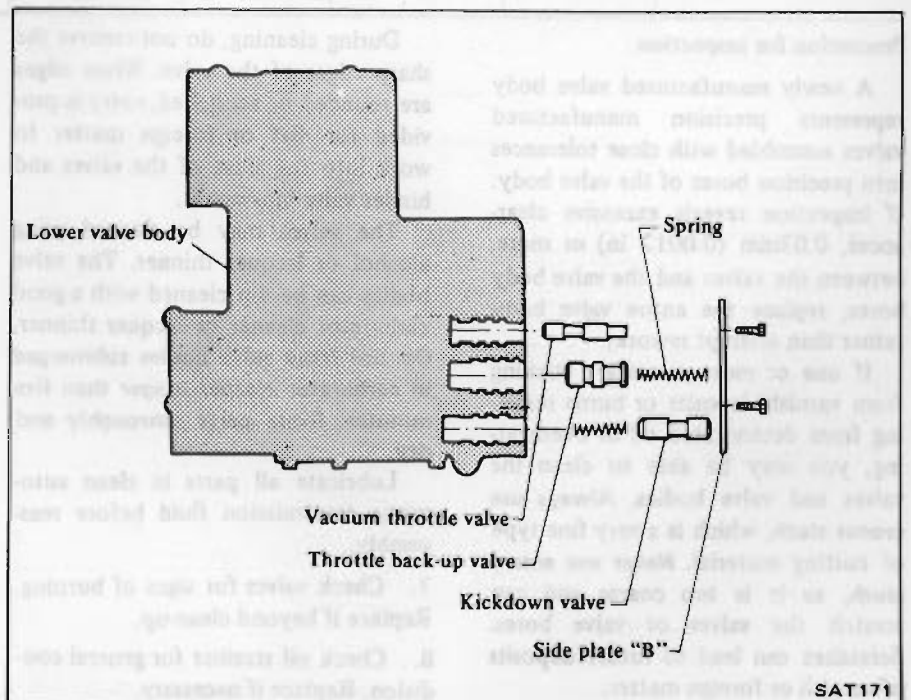

3. During valve body separation, do not scatter or lose orifice check valve, servo orifice check valve, and throttle

MAJOR OVERHAUL OPERATIONS

6. Remove side plate C, pressure modifier valve and spring, 2nd-3rd shift valve, spring and plug, and 1st-2nd shift valve and spring.

Place each loose part on a rack to retain sequence of assembly.

Manual valve was removed when valve body was removed from transmission. Include valve in subsequent inspection and service sequence.

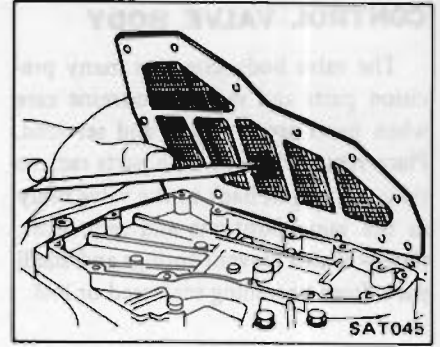
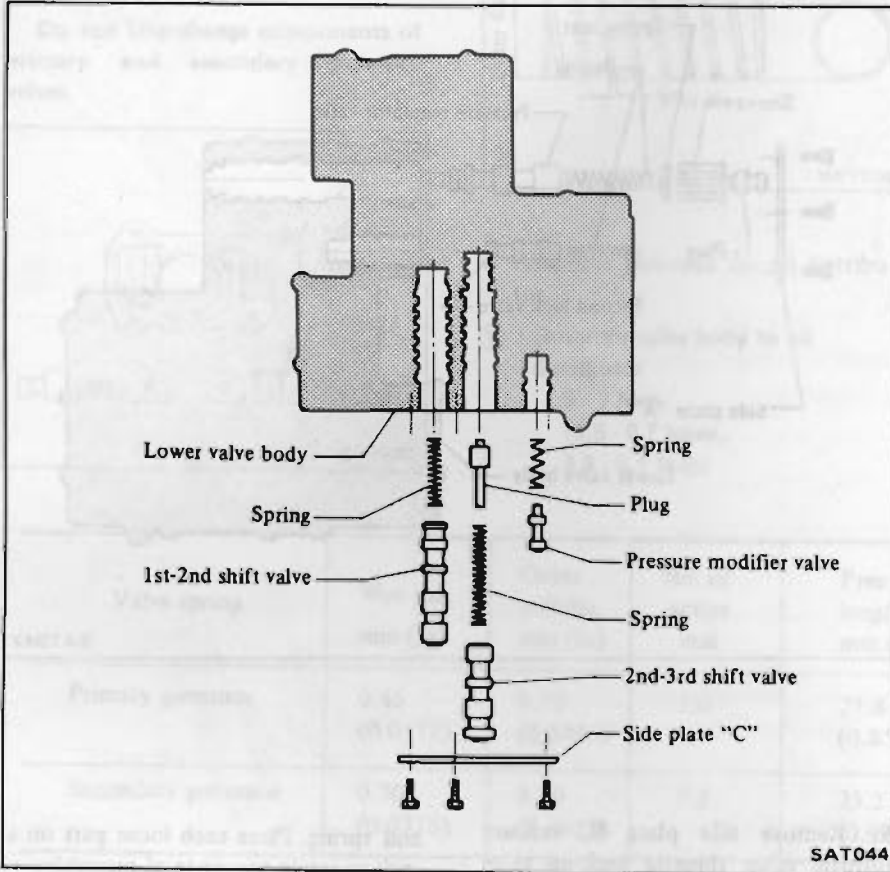

9. Check separator plate for scratches or damage. Replace if necessary. Scratches or score marks can cause oil to bypass correct oil passages and result in system malfunction.

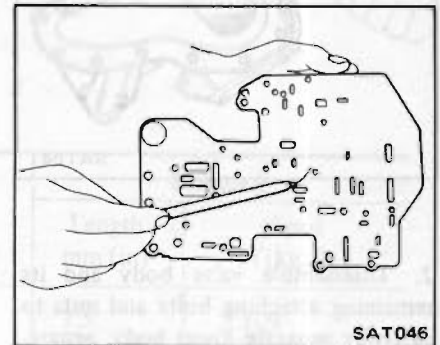

Precaution for inspection

A newly manufactured valve body represents precision manufactured valves assembled with close tolerances into precision bores of the valve body. If inspection reveals excessive clearances, 0.03mm (0.0012 in) or more, between the valves and the valve body bores, replace the entire valve body rather than attempt rework.

If one or more valves are sticking from varnish deposits or burns resulting from deteriorated oil or overheating, you may be able to clean the valves and valve bodies. **Always use crocus cloth**, which is a very fine type of cutting material. **Never use emery cloth**, as it is too coarse and can scratch the valves or valve bores. Scratches can lead to future deposits of varnish or foreign matter.

During cleaning, do not remove the sharp edges of the valve. When edges are rounded or scratched, entry is provided for dirt or foreign matter to work into the sides of the valves and hinder valve movement.

The valves may be cleaned using alcohol or lacquer thinner. The valve bodies can be dip cleaned with a good carburetor cleaner or lacquer thinner. **Do not leave valve bodies submerged in carburetor cleaner longer than five minutes. Rinse parts thoroughly and dry.**

Lubricate all parts in clean automatic transmission fluid before reassembly.

7. Check valves for signs of burning. Replace if beyond clean-up.

8. Check oil strainer for general condition. Replace if necessary.

10. Check oil passages in upper and lower valve bodies for varnish deposits, scratches or other damage that would impair valve movement. Check threaded holes and related bolts and screws for stripped threads; replace as needed.

11. Test valve springs for weakened load condition. Refer to Valve Body Spring Chart for spring specifications.

Valve body spring chart

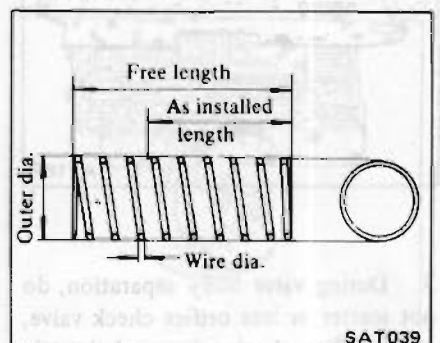

MAJOR OVERHAUL OPERATIONS

Valve spring	Wire dia. mm (in)	Outer coil dia. mm (in)	No. of active coil	Free length mm (in)	Installed	
					Length mm (in)	Load N (kg, lb)
Manual detent	1.3 (0.051)	7.3 (0.287)	15	32.4 (1.276)	26.5 (1.043)	53.9 (5.5, 12.1)
Pressure regulator valve	1.2 (0.047)	11.7 (0.461)	13	43.0 (1.693)	23.5 (0.925)	27.5 (2.8, 6.2)
Pressure modifier valve	0.4 (0.016)	8.4 (0.331)	5	18.5 (0.728)	9.0 (0.354)	1.0 (0.1, 0.2)
1st - 2nd shift valve	0.6 (0.024)	6.6 (0.260)	16	32.0 (1.260)	16.0 (0.630)	6.129 (0.625, 1.378)
2nd - 3rd shift valve	0.7 (0.028)	6.9 (0.272)	18	41.0 (1.614)	17.0 (0.669)	13.73 (1.40, 3.09)
Throttle back-up valve	0.8 (0.031)	7.3 (0.287)	14	36.0 (1.417)	18.8 (0.740)	18.83 (1.92, 4.23)
Solenoid downshift valve	0.55 (0.0217)	5.55 (0.2185)	12	22.0 (0.866)	12.5 (0.492)	5.88 (0.60, 1.32)
Second lock valve	0.55 (0.0217)	5.55 (0.2185)	16	33.5 (1.319)	21.0 (0.827)	5.88 (0.60, 1.32)
Throttle relief check valve	0.9 (0.035)	6.5 (0.256)	14	26.8 (1.055)	19.0 (0.748)	21.48 (2.19, 4.83)
Orifice check valve	0.23 (0.0091)	5.0 (0.197)	12	15.5 (0.610)	11.5 (0.453)	0.10 (0.01, 0.02)
Servo orifice check valve						

MAJOR OVERHAUL OPERATIONS

12. Assemble side plate A group of parts into lower valve body. Reinstall

side plate and finger tighten screws.

Assemble side plate B group and

side plate C group in same manner as A group.

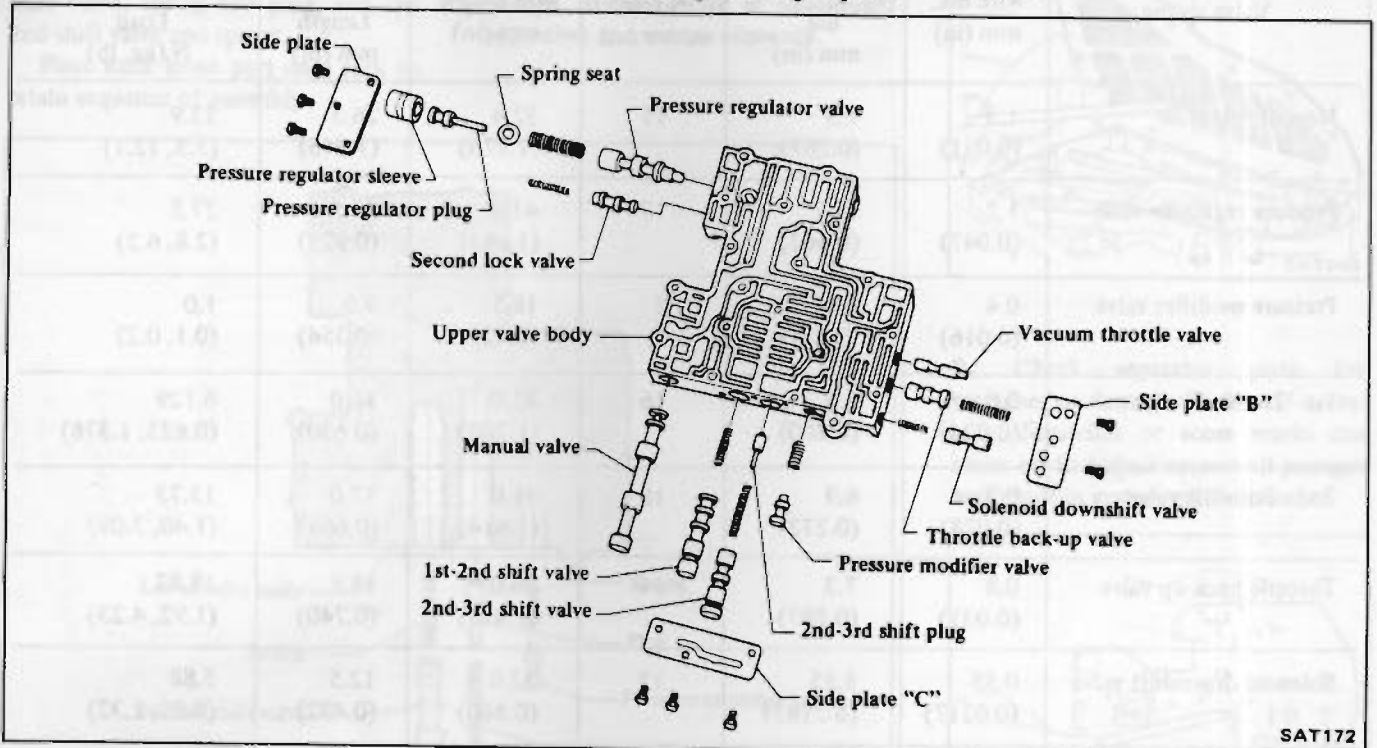

13. Tighten screws.

- ⊕ : Side plate to valve body
2.5 - 3.4 N-m
(0.25 - 0.35 kg-m,
1.8 - 2.5 ft-lb)

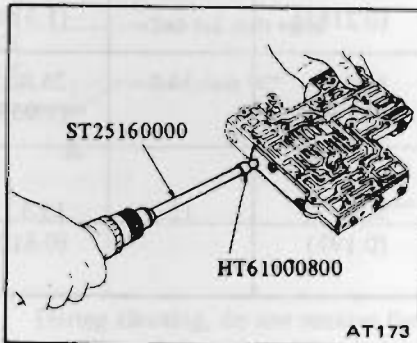

14. Install orifice check valve, valve spring, throttle relief valve spring and steel ball in valve body.

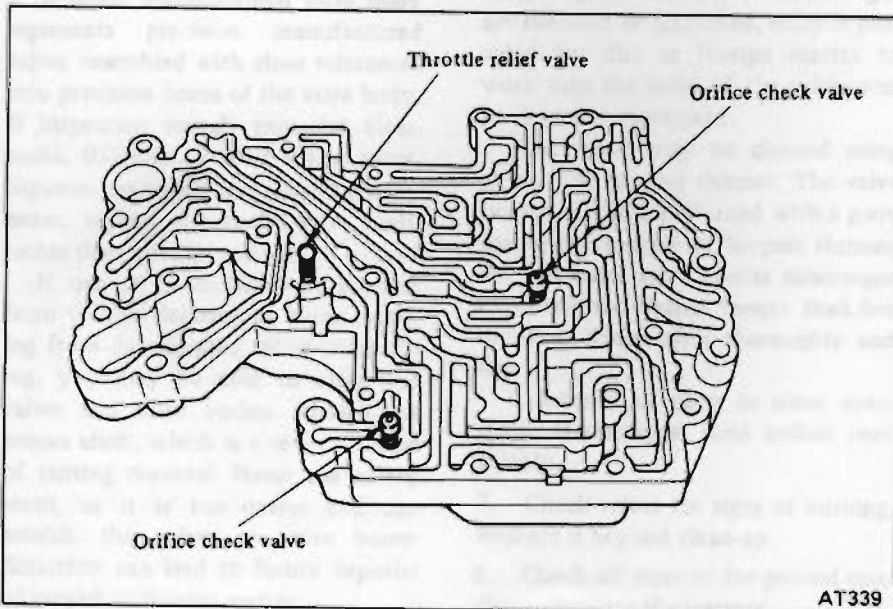

15. Install upper and lower valves.

- ⊕ : Upper and lower valves:
2.5 - 3.4 N-m
(0.25 - 0.35 kg-m,
1.8 - 2.5 ft-lb)
- Reamer bolt:
5 - 7 N-m
(0.5 - 0.7 kg-m,
3.6 - 5.1 ft-lb)

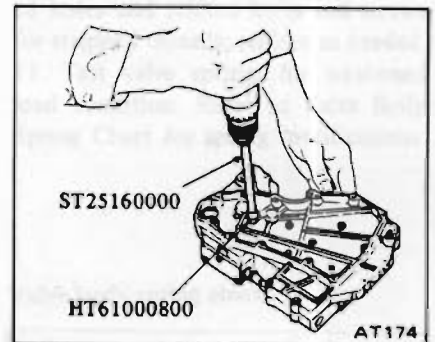

16. Install oil strainer.

- ⊕ : Oil strainer to valve body
2.5 - 3.4 N-m
(0.25 - 0.35 kg-m,
1.8 - 2.5 ft-lb)

The manual valve is inserted into the valve body when the latter is installed in the transmission.

FINAL ASSEMBLY

When installing/assembling needle

bearing, bearing race, snap ring and O-ring (seal ring), use the following

illustration as a guide to installation procedures and locations.

“••” indicates snap ring and “••••” needle thrust bearing, respectively. Nos. with “••” or “••••” are listed in order of size.

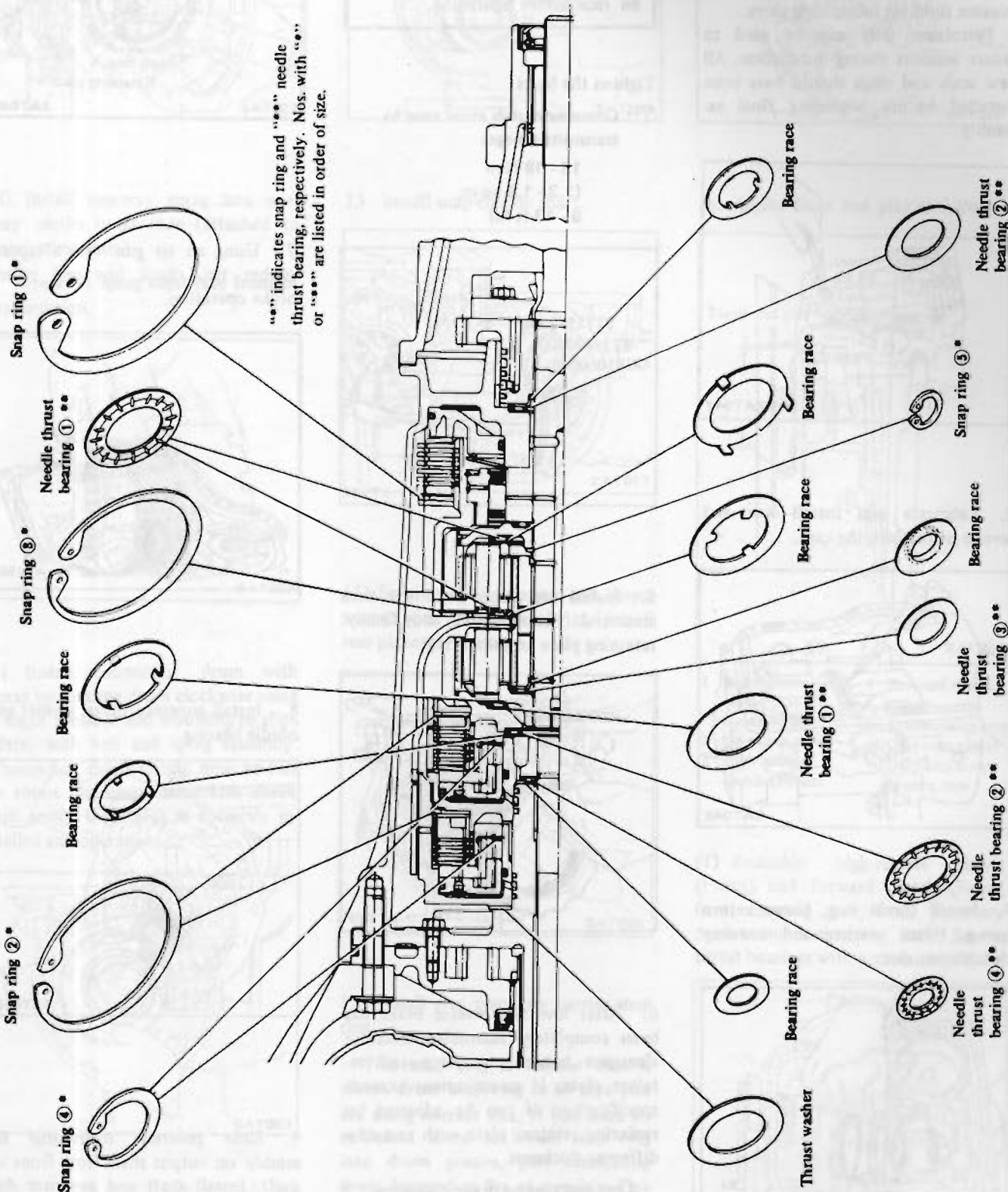

MAJOR OVERHAUL OPERATIONS

1. Before proceeding with the final assembly of all components, it is important to verify that the case, housing and parts are clean and free from dust, dirt and foreign matter (use air gun). Have a tray available with clean transmission fluid for lubricating parts.

Petroleum jelly can be used to secure washers during installation. All new seals and rings should have been installed before beginning final assembly.

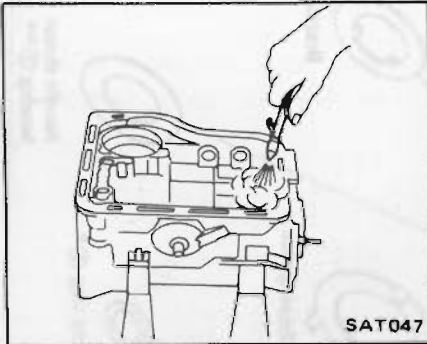

2. Lubricate and install low and reverse piston into the case.

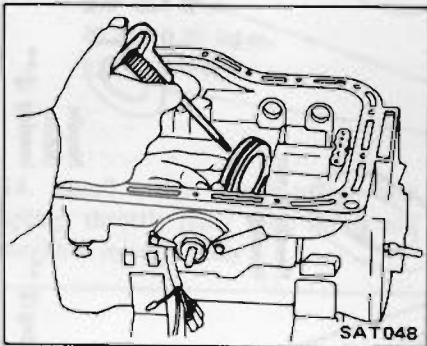

3. Install thrust ring, piston return spring, thrust washer and one-way clutch inner race.

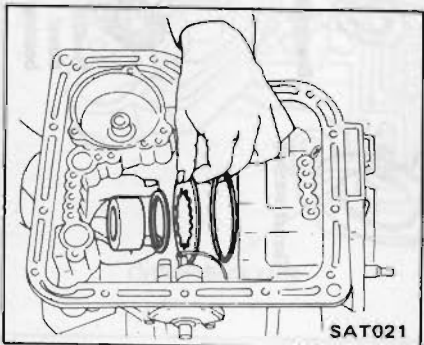

4. Align and start hex-head slotted bolts into inner race from rear of case.

WARNING:
Check that return spring is centered on race before tightening.

Tighten the bolts

⊕: One-way clutch inner race to transmission case

13 - 18 N·m
(1.3 - 1.8 kg·m,
9 - 13 ft·lb)

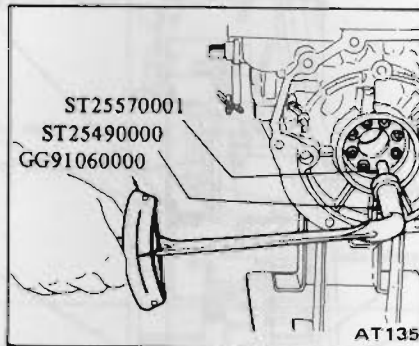

5. Install steel dished plate first, then steel and friction plates, and, finally, retaining plate and snap-ring.

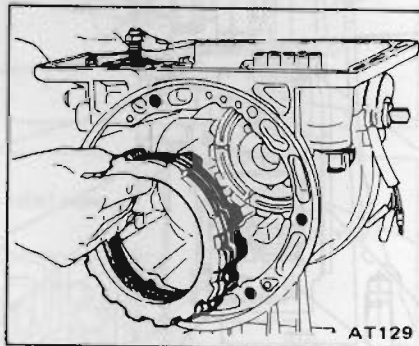

6. After low and reverse brake has been completely assembled, measure clearance between snapping and retainer plate. If measurement exceeds specifications it can be adjusted by replacing retainer plate with one of a different thickness.

Low and reverse brake clearance:
0.80 - 1.25 mm
(0.0315 - 0.0492 in)

AT-28

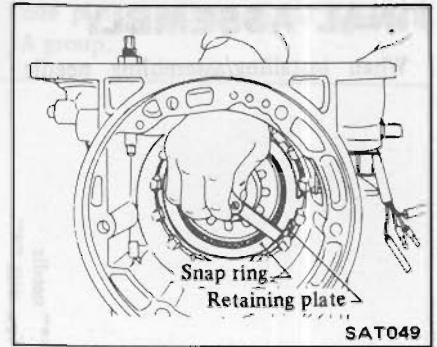

7. Using an air gun with a tapered rubber tip, check low and reverse brake operation.

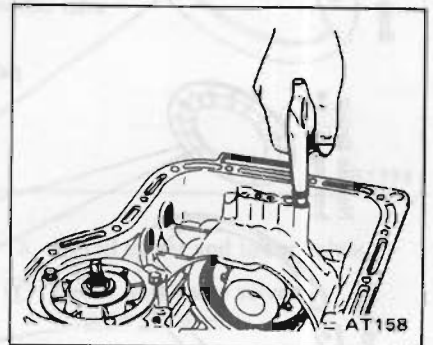

8. Install governor thrust washer and needle bearing.

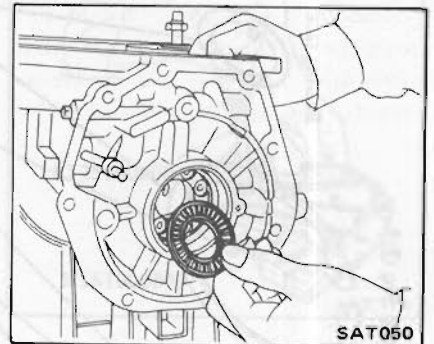

9. Slide governor distributor assembly on output shaft from front of shaft. Install shaft and governor distributor into case, using care not to damage distributor rings.

MAJOR OVERHAUL OPERATIONS

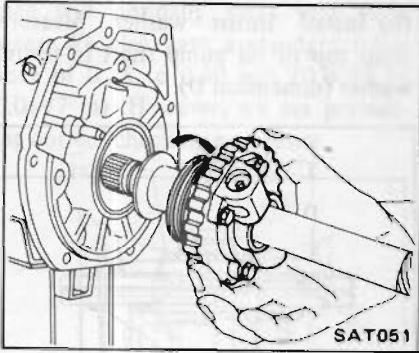

10. Install one-way sprag into one-way clutch outer race (attached to connecting drum).

Arrow on sprag must face front of transmission.

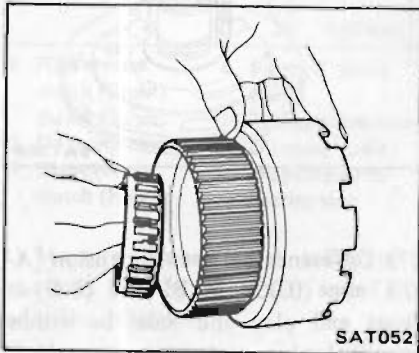

11. Install connecting drum with sprag by rotating drum clockwise using a slight pressure and wobbling to align plates with hub and sprag assembly. Connecting drum should now be free to rotate **clockwise only**. This check will verify that sprag is correctly installed and operative.

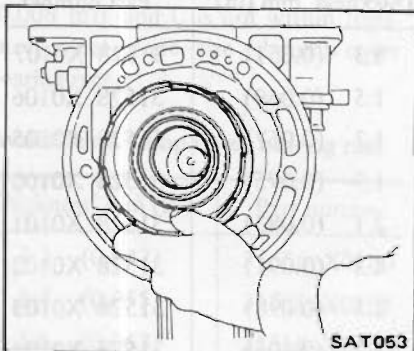

12. Install rear internal gear.

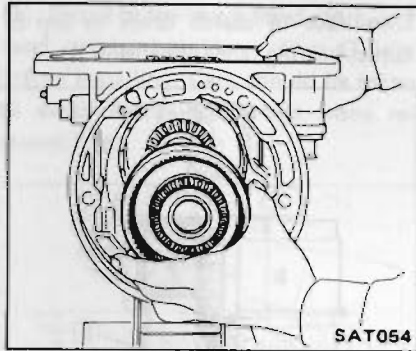

13. Install snap-ring on shaft.

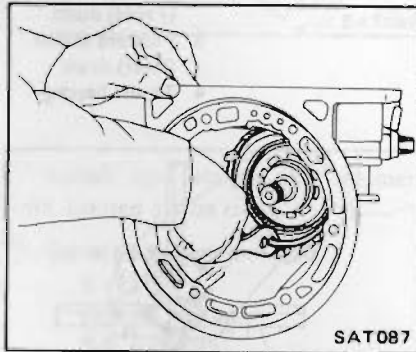

14. Secure thrust bearing and thrust washer with petroleum jelly and install rear planetary carrier.

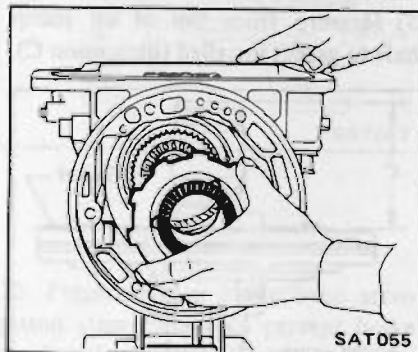

15. Install rear planetary carrier snap ring.

This snap ring is thinner than a clutch drum snap ring so be sure you are using correct size. If you have insufficient space to install snap ring into drum groove, pull connecting drum forward as far as possible. This will give you sufficient groove clearance to install drum snap ring.

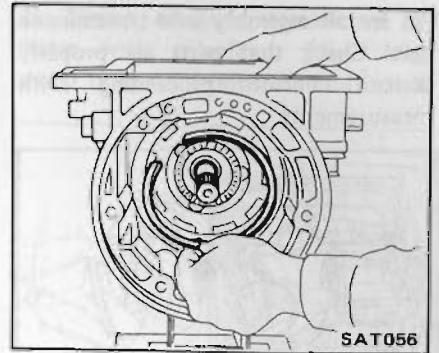

16. Adjust front end play as follows:

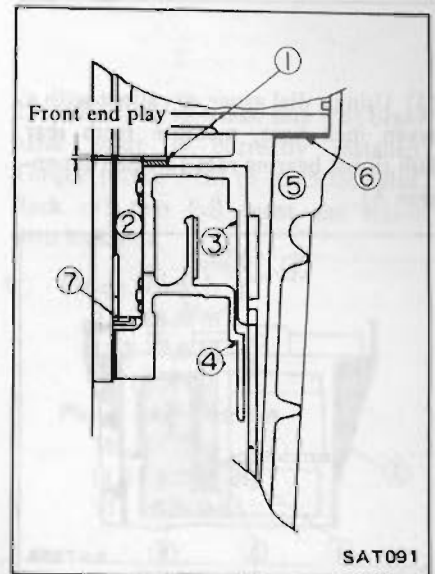

- | | |
|---|-------------------------------|
| 1 High-reverse clutch (Front) thrust washer | 4 Forward clutch (Rear) |
| 2 Oil pump cover | 5 Transmission case |
| 3 High-reverse clutch (Front) | 6 Oil pump gasket |
| | 7 Oil pump cover bearing race |

(1) Assemble high-reverse clutch (Front) and forward clutch (Rear), front internal gear, front planetary carrier and connecting shell. Secure thrust bearings with petroleum jelly.



MAJOR OVERHAUL OPERATIONS

(2) Install assembly into transmission case. Check that parts are properly seated before proceeding with measurements.

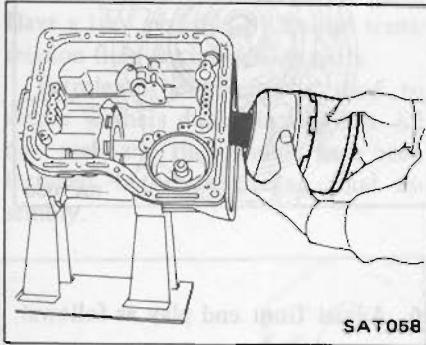

from face of clutch drum to top of thrust bearing race (dimension B).

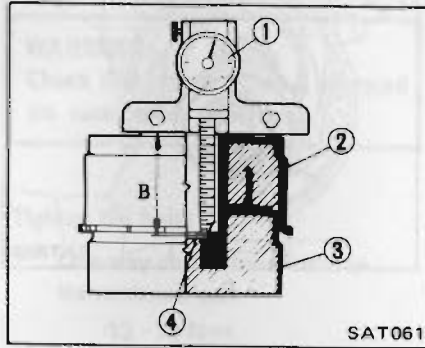

- 1 Depth gauge
- 2 High-reverse clutch (Front) drum
- 3 Forward clutch (Rear) drum
- 4 Thrust bearing

(6) Install thrust washer. Measure from top of oil pump shaft to thrust washer (dimension D).

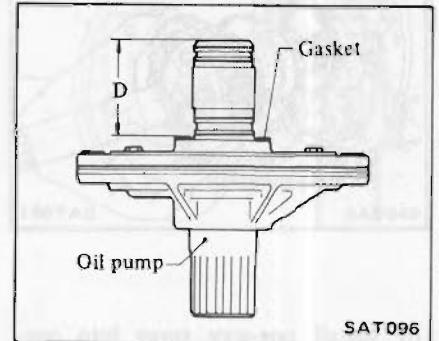

(3) Using a dial gauge or caliper with a seven inch base, measure from rear hub thrust bearing race to case (dimension A).

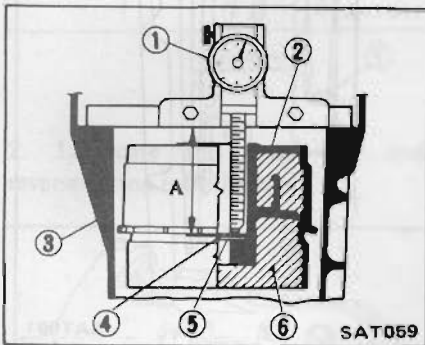

- 1 Dial gauge
- 2 High-reverse clutch (Front) drum
- 3 Transmission case
- 4 Bearing race
- 5 Thrust bearing
- 6 Forward clutch (Rear) drum

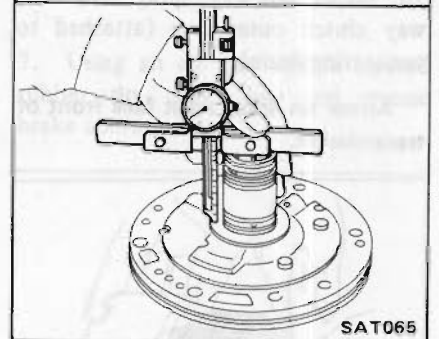
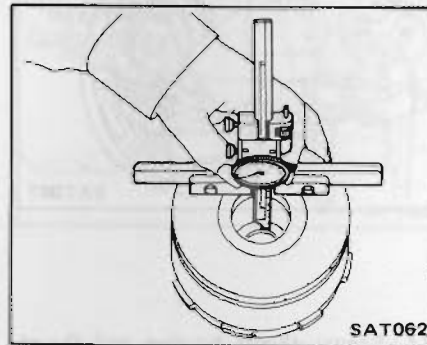

(7) Difference between dimension [A - 0.1 mm (0.004 in) - B] and (C-D) is front end play and must be within specified value.

Specified front end play:
0.5 - 0.8 mm
(0.020 - 0.031 in)

Front end play can be adjusted with high-reverse clutch (Front) thrust washers of different thickness.

Available high-reverse clutch (Front) thrust washer

Thickness mm (in)	Part number
1.3 (0.051)	31528 X0107
1.5 (0.059)	31528 X0106
1.7 (0.067)	31528 X0105
1.9 (0.075)	31528 X0100
2.1 (0.083)	31528 X0101
2.3 (0.091)	31528 X0102
2.5 (0.098)	31528 X0103
2.7 (0.106)	31528 X0104

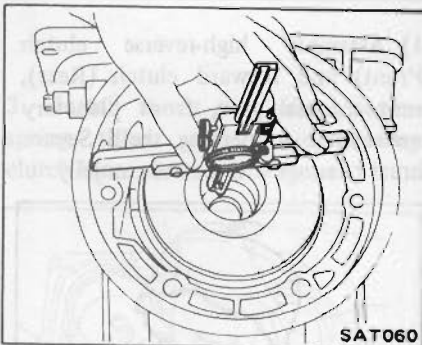

(4) Assemble high-reverse clutch (Front) and forward clutch (Rear) drum assemblies together and lay them flat on bench. Be sure rear hub thrust bearing is properly seated. Measure

(5) Measure from top of oil pump shaft to gasket installed (dimension C).

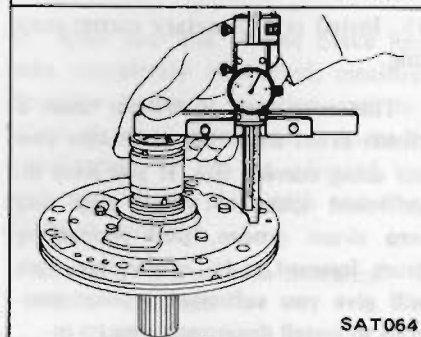
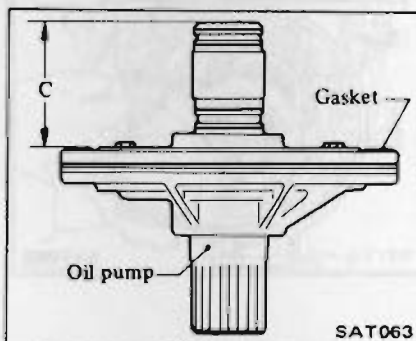

17. Adjust total end play as follows:
This adjustment is seldom required because this type of thrust bearing and

MAJOR OVERHAUL OPERATIONS

race will normally show very little wear. We also have a standard tolerance of 0.25 to 0.50 mm (0.0098 to 0.0197 in). However, we are presenting correct checking procedure.

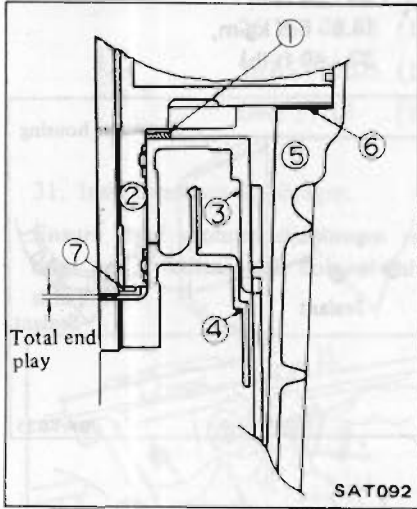

- | | |
|---|-------------------------------|
| 1 High-reverse clutch (Front) thrust washer | 4 Forward clutch (Rear) |
| 2 Oil pump cover | 5 Transmission case |
| 3 High-reverse clutch (Front) | 7 Oil pump cover bearing race |

(1) Measure dimension A using instructions in steps (1), (2) and (3) under No. 16 above.

(2) Measure dimension C using instructions in step (5) under No. 16 above.

(3) Difference between dimension [A-0.1 mm (0.004 in)] and C is total end play and it must be within specified value.

Specified total end play:
0.25 - 0.50 mm
(0.0098 - 0.0197 in)

If difference between [A-0.2 mm (0.008 in)] and C is not within tolerance, select proper size oil pump cover bearing race.

Available oil pump cover bearing race

Thickness mm (in)	Part number
1.2 (0.047)	31556 X0100
1.4 (0.055)	31556 X0101
1.6 (0.063)	31556 X0102
1.8 (0.071)	31556 X0103
2.0 (0.079)	31556 X0104
2.2 (0.087)	31556 X0105

18. Install brake band, band strut, and band servo. Lubricate servo O-rings before installing. Care should be taken to avoid damaging O-rings when re-assembling.

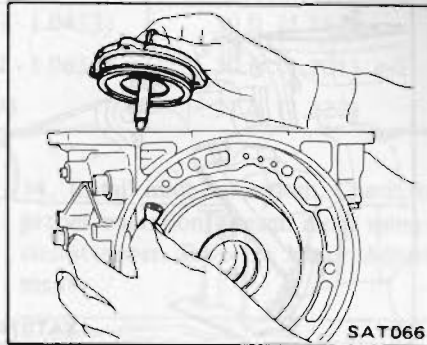

19. Install and torque the retainer bolts. Loosen piston stem.

- ⊕ : Servo piston retainer bolt
5 - 7 N·m
(0.5 - 0.7 kg·m,
3.6 - 5.1 ft·lb)

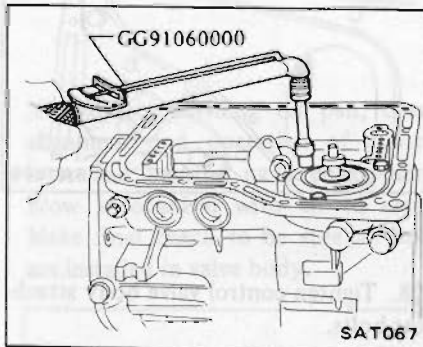

20. Finger tighten brake band servo piston stem enough to prevent brake band and strut from falling out. Do not adjust brake band at this time.

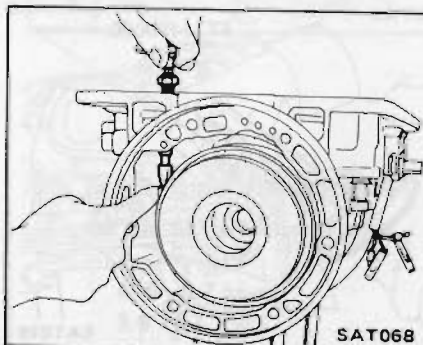

21. Mount oil pump gasket on oil pump with petroleum jelly. Align pump to transmission case and install.

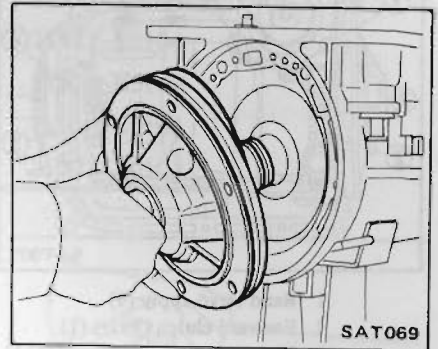

22. Adjust band. Make sure that brake band strut is correctly installed. Torque piston stem to specified value. Back off two full turns and secure with lock nut.

- ⊕ : Piston stem
12 - 15 N·m
(1.2 - 1.5 kg·m,
9 - 11 ft·lb)
Piston stem lock nut
15 - 39 N·m
(1.5 - 4.0 kg·m,
11 - 29 ft·lb)

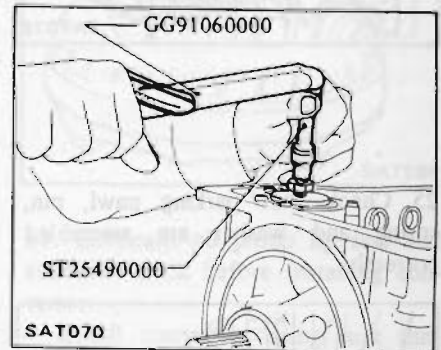

23. Before proceeding with installation of valve body assembly, perform a final air check of all assembled components. This will ensure that you have not overlooked tightening of any bolts or damaged any seals during assembly.

Air check point

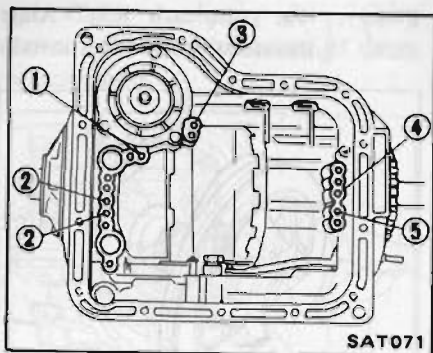

- 1 Band servo apply (9)
- 2 Forward clutch (Rear) (1)
High-reverse clutch (Front) (11)
- 3 Band servo release (10)
- 4 Governor feed (1)
- 5 Low & reverse brake (12)

⊕ : Rear extension to transmission case

20 - 25 N-m
(2.0 - 2.5 kg-m,
14 - 18 ft-lb)

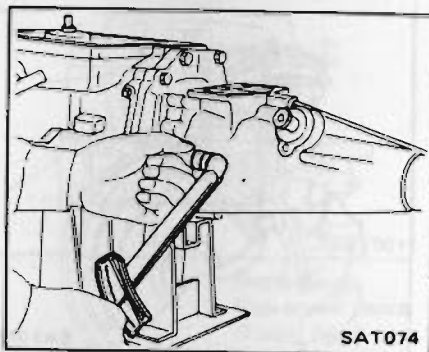

27. Install control valve body. Be sure manual valve is in alignment with selector pin.

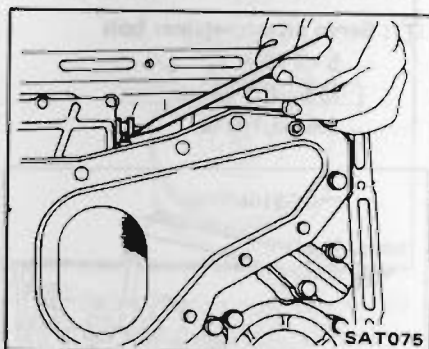

28. Tighten control valve body attaching bolts.

⊕ : 5.4 - 7.4 N-m
(0.55 - 0.75 kg-m,
4.0 - 5.4 ft-lb)

Control valve body attaching bolts vary in length. Care must be taken to ensure that each bolt is returned to correct hole.

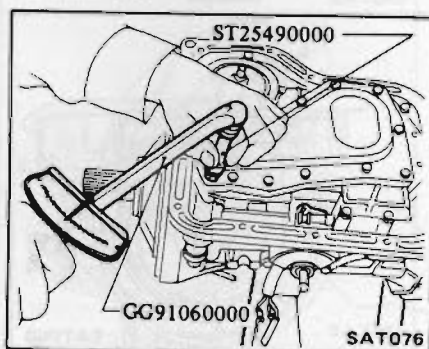

29. Check pump to transmission alignment and install converter housing.

Apply sealant to portions shown in the figure.

⊕ : 44 - 54 N-m
(4.5 - 5.5 kg-m,
33 - 40 ft-lb)

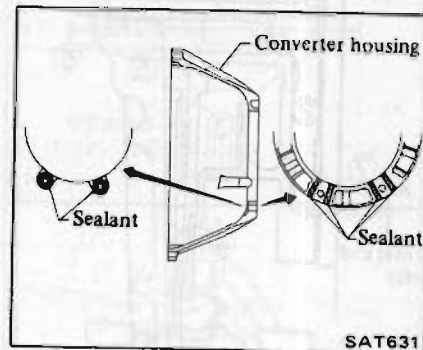

30. Before installing vacuum diaphragm valve, measure depth of hole in which it is inserted. This measurement determines correct rod length to ensure proper performance.

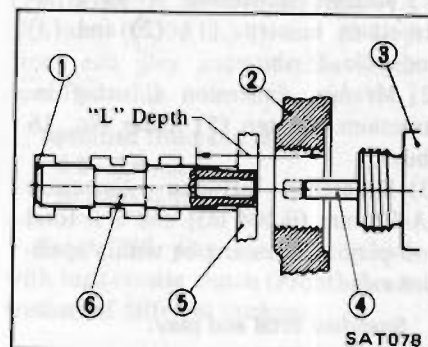

- 1 Note seated valve body
- 2 Transmission case wall
- 3 Vacuum diaphragm
- 4 Diaphragm rod
- 5 Valve body side plate
- 6 Vacuum throttle valve

24. Using an air gun with a tapered rubber tip, perform air checks.

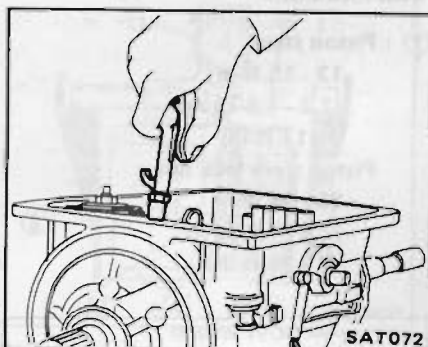

25. Check that parking pawl, pin, spring and washer are assembled correctly.

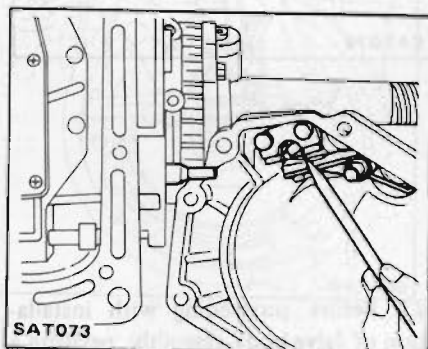

26. Install rear extension.

MAJOR OVERHAUL OPERATIONS

Vacuum diaphragm rod selection

Measured depth "L" mm (in)	Rod length mm (in)	Part number
Under 25.55 (1.0059)	29.0 (1.142)	31932 X0103
25.65 - 26.05 (1.0098 - 1.0256)	29.5 (1.161)	31932 X0104
26.15 - 26.55 (1.0295 - 1.0453)	30.0 (1.181)	31932 X0100
26.65 - 27.05 (1.0492 - 1.0650)	30.5 (1.201)	31932 X0102
Over 27.15 (1.0689)	31.0 (1.220)	31932 X0101

31. Install vacuum diaphragm.

Ensure that vacuum diaphragm rod does not interfere with control valve side plate.

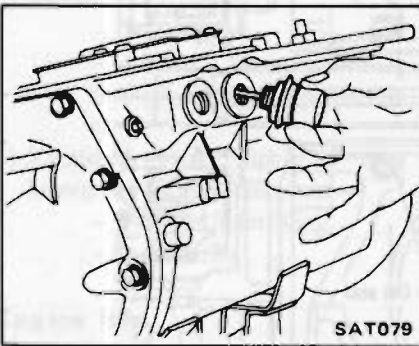

34. Install inhibitor switch. Check for proper operation in each range using a circuit tester. Refer to Minor Adjustment.

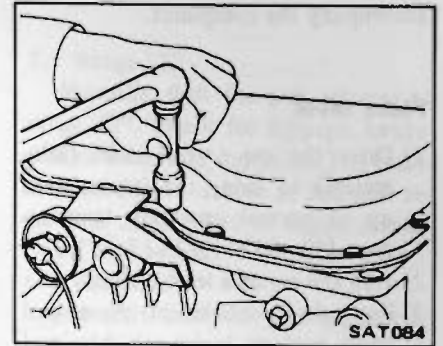
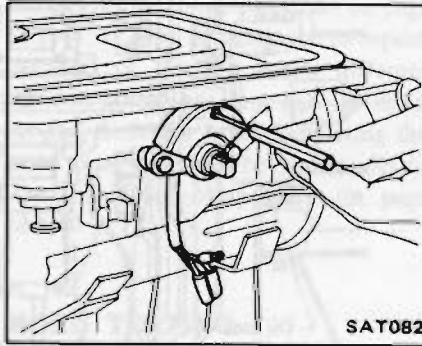

32. Before installing down shift solenoid, check to verify that it is operating properly. Use a hot lead and ground to check solenoid.

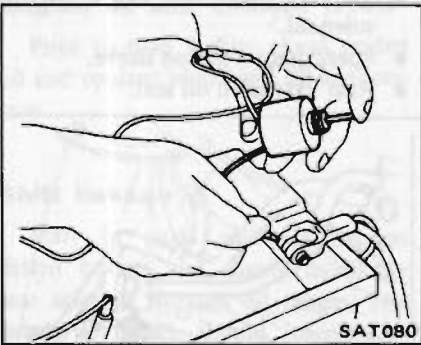

33. Install down shift solenoid.

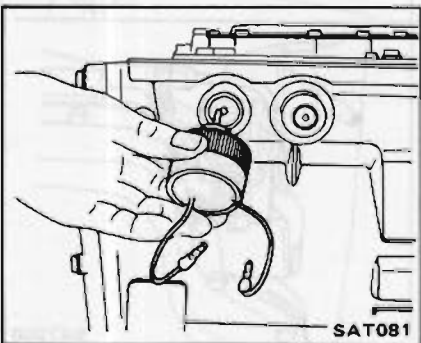

35. Before installing oil pan, check alignment and operation of control lever and parking pawl engagement. Blow mechanism with air to clean. Make final check to be sure all bolts are installed in valve body.

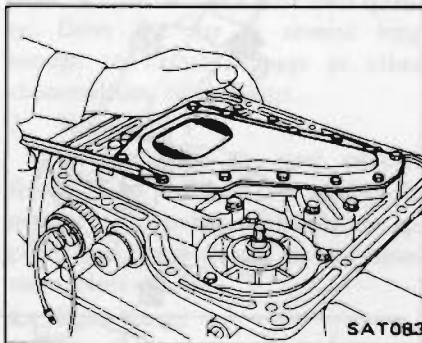

37. Carefully inspect torque converter for damage. Check converter hub for grooves caused by hardened seals. Also check bushing contact area.

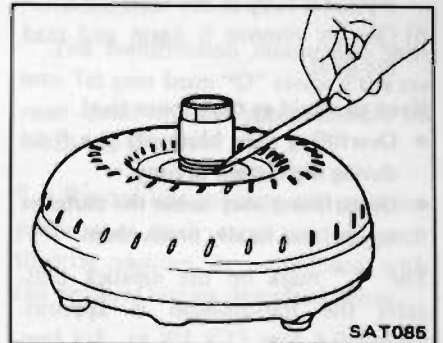

38. Lubricate oil pump lip seal and converter neck before installing converter.

Install converter, being sure that converter is properly meshed with oil pump drive gear.

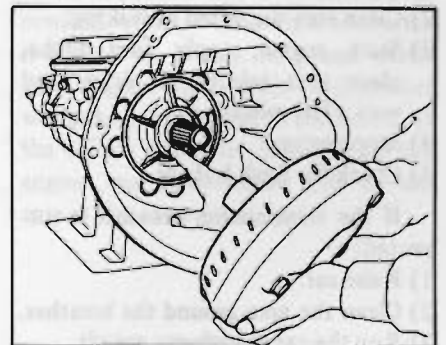

36. Install oil pan with new gasket.

⊕ : Oil pan to transmission case
 5 - 7 N·m
 (0.5 - 0.7 kg·m,
 3.6 - 5.1 ft·lb)

TROUBLE-SHOOTING AND DIAGNOSES

PRELIMINARY CHECKS (Prior to road testing)

Verify customer complaint

The customer should supply as much information as possible, including any unusual characteristics that accompany the complaint.

Fluid level

- 1) Drive the car several miles (kilometers) to bring the transmission up to normal operating temperature. [50 - 80°C (122 - 176°F)]
- 2) Park the car on a level surface.
- 3) Put wheel chocks in place and apply parking brake securely, and leave the engine running.
- 4) Slowly move the gear selector through the entire shift pattern, and return it to park.
- 5) Remove the dipstick, clean it, and replace it fully in the filler tube.
- 6) Quickly remove it again and read the level.

Keep the fluid at the proper level.

- Overfilling may blow off the fluid during high speed driving.
- Underfilling may cause the clutches to slip, and finally break them.

The "L" mark on the dipstick indicates the transmission is approximately 0.4 liter (7/8 US pt, 3/4 Imp pt) low. Add only clean Dexron transmission fluid (or equivalent).

Fluid leakage

To detect a fluid leak:

- 1) Raise car.
- 2) Clean area suspected of leaking.
- 3) Start engine, apply foot brake, place gear selector in drive, and wait a few minutes.
- 4) Stop engine.
- 5) Check for fresh leakage.

If the transmission breather is suspected:

- 1) Raise car.
- 2) Clean the area around the breather.
- 3) Run the car at highway speeds.

- 4) Check the breather for fresh leakage.

To aid in locating leaks, use the following list of seals and gaskets.

- 1) Converter housing

- Rubber O-ring of oil pump housing.
- Oil pump housing oil seal (transmission front seal).
- Crankshaft oil seal.
- Bolts of converter housing to case.

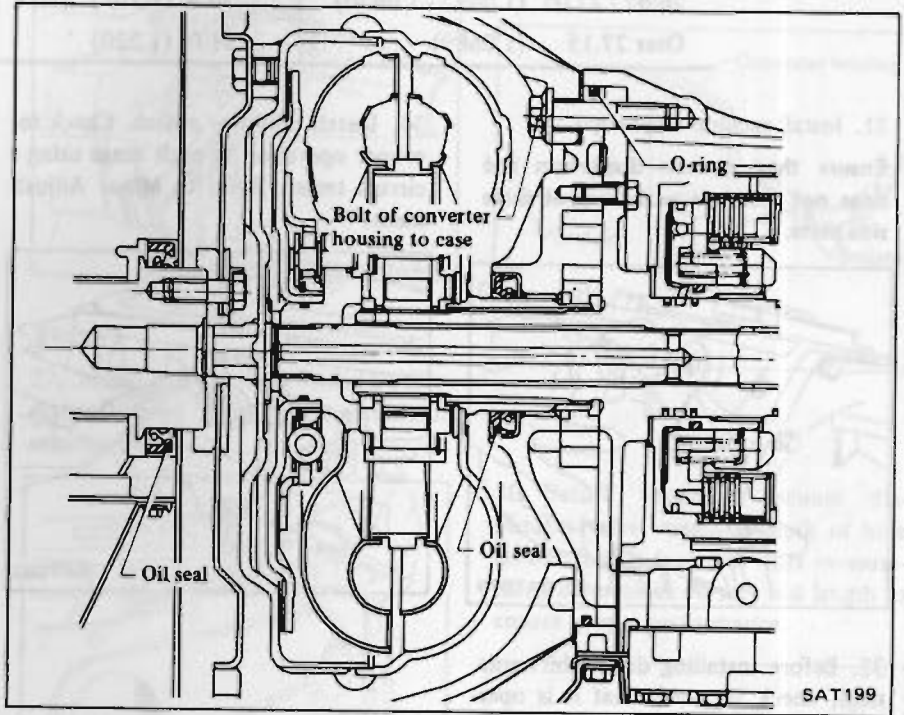

SAT199

- 2) Transmission and rear extension.
 - Junction of transmission and rear extension.
 - Oil cooler tube connectors.
 - Oil pressure inspection ports.

- Governor tube connectors.
- Vacuum diaphragm and downshift solenoid.
- Speedometer pinion sleeve.
- Rear extension oil seal.

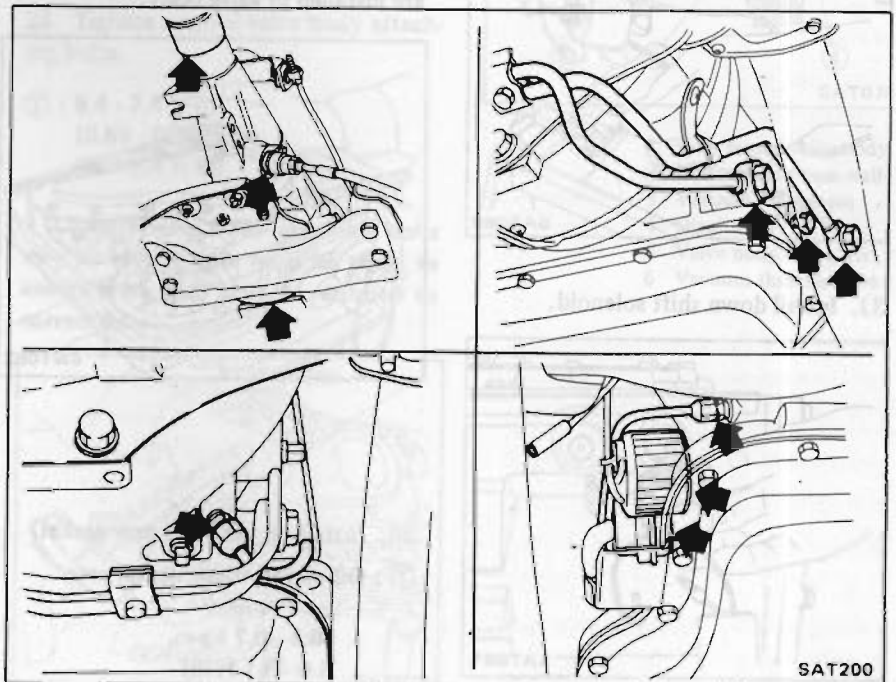

SAT200

Fluid condition

Transmission fluid color and texture can aid greatly in transmission trouble-shooting. When checking fluid level, examine the transmission fluid and note its color, texture, and odor. Some common forms of contamination are listed below:

- 1) Dark or Black Fluid:
 - With a burned odor
 - Worn friction material.
 - Without an odor
 - Slight engine coolant leak (in radiator).
- 2) Milky Pink Fluid: Water Contamination
 - Coolant leak.
 - Road water entering through filler tube or breather.
- 3) Varnished Fluid, light to dark brown and tacky: Oxidation
 - Over or Underfilling.
 - Overheating.

Engine idle

Check and adjust idle to specifications.

Idling speed

Refer to MA section.

Engine oil and coolant levels

Prior to road testing, check engine oil and coolant levels, and fill as necessary.

Shift linkage

Start in park position, depress detent button and slowly move the gear selector through all ranges. The detent "clicks" should correspond with the range indicator.

DIAGNOSTIC ROAD TEST

Prior to road testing, perform the preliminary inspections outlined earlier. If the car is not equipped with a tachometer, install a portable tachometer in the car. And also install a suitable vacuum gauge and pressure gauge. If the customer has a specific complaint, select road conditions similar to those described. (e.g. steep hills, freeways, etc.)

Follow the test sequence as outlined in this section and mark the results on the Symptom Chart on page AT-44. It may be necessary to repeat sections of the test under different throttle conditions. (e.g. light, medium or full throttle.) After completing the road test, compare the test results to the Trouble-shooting Chart on page AT-40.

ROAD TESTING**1. Park Range**

Place the gear selector in "P" range and start the engine. Stop the engine and repeat the procedure in all other ranges and neutral. In park, the car should be locked in position, unable to roll or move. Mark all results on the Symptom Chart.

2. Reverse

Manually shift the gear selector from "P" to "R", and note shift quality. Drive the car in reverse long enough to detect slippage or other abnormalities. Note results.

3. Neutral

Manually shift the gear selector from "P" to "N" and note quality. In neutral no clutches or bands are applied, and there should be no movement. Note results.

4. Drive Range

Manually shift the gear selector to range "D", and note shift quality. Drive the car through all automatic shifts and in all gear ranges. Note shift quality and timing [km/h (MPH)], and check whether torque converter is

locked up or not at specified speed. Refer to Confirming lock-up state of torque converter. Check for slippage, noise, or other abnormal conditions. If necessary, drive the test sequence under different throttle opening (e.g. light, medium or full throttle).

Lock-up zone

Refer to shift schedule on page AT-37.

5. Range "2"

Manually shift the gear selector to range "2". Check for slippage, hesitation or abnormal condition. The transmission should remain in 2nd gear regardless of car speed or engine revolutions. Note results.

6. Range "1"

Manually shift the gear selector to range "1". Note shift quality. It should, however, downshift immediately to 2nd gear and downshift again to 1st gear as road speed decreases. Accelerate and decelerate in 1st gear to determine engine braking. Note results.

The transmission should not shift into 1st gear from "D" range if the car road speed is above approximately 65 km/h (40 MPH).

7. Record line pressure and governor pressure at each range and at each throttle vacuum in accordance with the pressure testing described below.

CONFIRMING LOCK-UP STATE OF TORQUE CONVERTER

Because the shock is very low and is not noticeable when the torque converter is locked up, it is difficult to confirm whether the torque converter is locked up or not. So please check the engine rpm with tachometer while the car is driving to confirm it. If the torque converter is locked up the engine rpm is decreased 200 to 400 rpm at the same time.

TROUBLE-SHOOTING AND DIAGNOSES

Car speed and line pressure when shifting gears

L28E engine model

Intake manifold vacuum -kPa (-mmHg, -inHg)	Gearshift	Car speed * km/h (MPH)	Propeller shaft revolutions rpm	Line pressure kPa (kg/cm ² , psi)
0 (0, 0) (Kickdown)	D ₁ → D ₂	61 - 69 (38 - 43)	1,870 - 2,120	716 - 873 (7.3 - 8.9, 104 - 127)
	D ₂ → D ₃	104 - 112 (65 - 70)	3,210 - 3,460	
	D ₃ → D ₂	103 - 95 (64 - 59)	3,170 - 2,920	
	D ₂ → D ₁	54 - 46 (34 - 29)	1,670 - 1,420	
13.3 (100, 3.94)	D ₁ → D ₂	19 - 28 (12 - 17)	600 - 850	569 - 726 (5.8 - 7.4, 82 - 105)
	D ₂ → D ₃	59 - 67 (37 - 42)	1,830 - 2,080	
	D ₃ → D ₂	42 - 34 (26 - 21)	1,300 - 1,050	
	D ₂ → D ₁	19 - 11 (12 - 7)	600 - 350	
0 (0, 0) (Full throttle)	l ₂ → l ₁	55 - 47 (34 - 29)	1,700 - 1,450	755 - 912 (7.7 - 9.3, 109 - 132)
40.0 (300, 11.81)	l ₂ → l ₁	55 - 47 (34 - 29)	1,700 - 1,450	755 - 912 (7.7 - 9.3 - 109 - 132)

L28ET engine model

Intake manifold vacuum kPa (mmHg, inHg)	Gearshift	Car speed * km/h (MPH)	Propeller shaft revolutions rpm	Line pressure kPa (kg/cm ² , psi)
46.7 (350, 13.78) (Kickdown)	D ₁ → D ₂	62 - 70 (38 - 43)	1,900 - 2,150	569 - 686 (5.8 - 7.0, 82 - 100)
	D ₂ → D ₃	92 - 100 (57 - 62)	2,840 - 3,090	
	D ₃ → D ₂	92 - 84 (57 - 52)	2,820 - 2,570	
	D ₂ → D ₁	46 - 38 (29 - 24)	1,430 - 1,180	
0 (0, 0)	D ₁ → D ₂	25 - 33 (16 - 21)	780 - 1,030	559 - 657 (5.7 - 6.7, 81 - 95)
	D ₂ → D ₃	73 - 82 (46 - 51)	2,260 - 2,510	
	D ₃ → D ₂	50 - 42 (31 - 26)	1,550 - 1,300	
	D ₂ → D ₁	19 - 11 (12 - 7)	600 - 350	
-26.7 (-200, -7.87)	D ₁ → D ₂	13 - 21 (8 - 13)	400 - 650	382 - 481 (3.9 - 4.9, 55 - 70)
	D ₂ → D ₃	26 - 34 (16 - 21)	790 - 1,040	
	D ₃ → D ₂	19 - 11 (12 - 7)	600 - 350	
	D ₃ → D ₁		600 - 350	
	D ₂ → D ₁		600 - 350	
46.7 (350, 13.78)	l ₂ → l ₁	38 - 46 (24 - 29)	1,180 - 1,430	569 - 696 (5.8 - 7.1, 82 - 101)
-60.0 (-450, -17.72)	l ₂ → l ₁	38 - 46 (24 - 29)	1,180 - 1,430	569 - 696 (5.8 - 7.1, 82 - 101)

: means negative pressure.

TROUBLE-SHOOTING AND DIAGNOSES

Shift schedule

————— ... Upshift - - - - - ... Downshift

L28E engine model

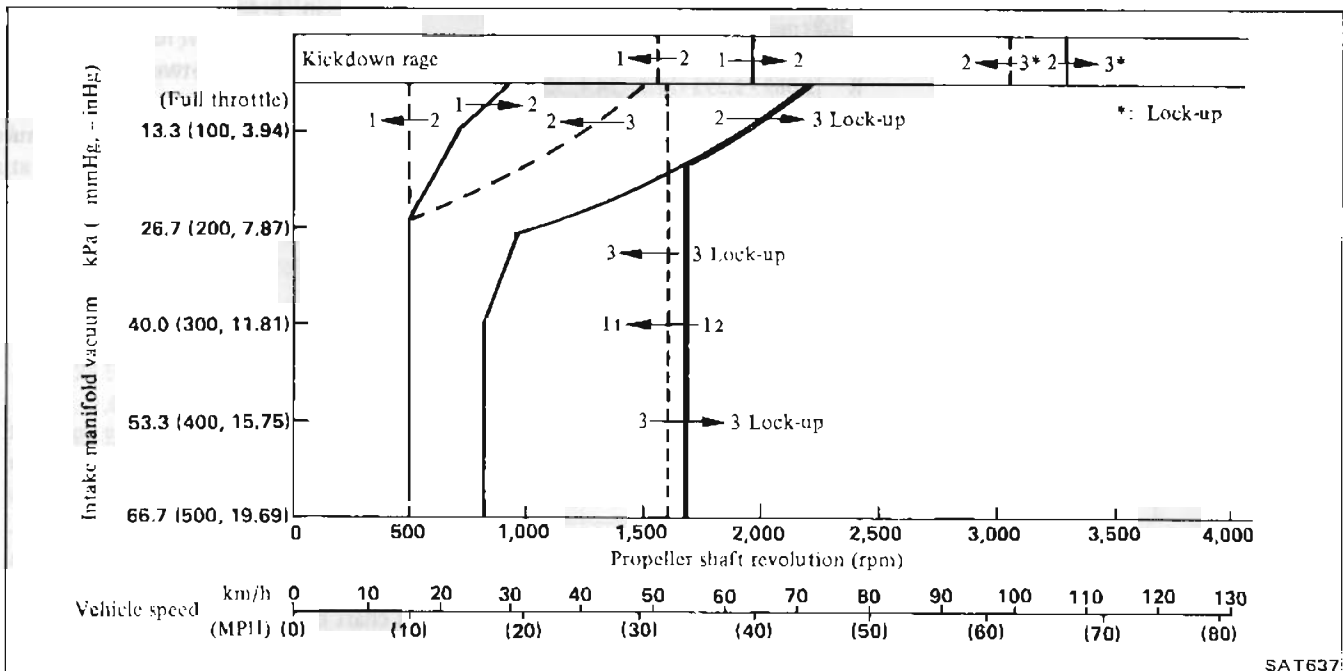

L28ET engine model

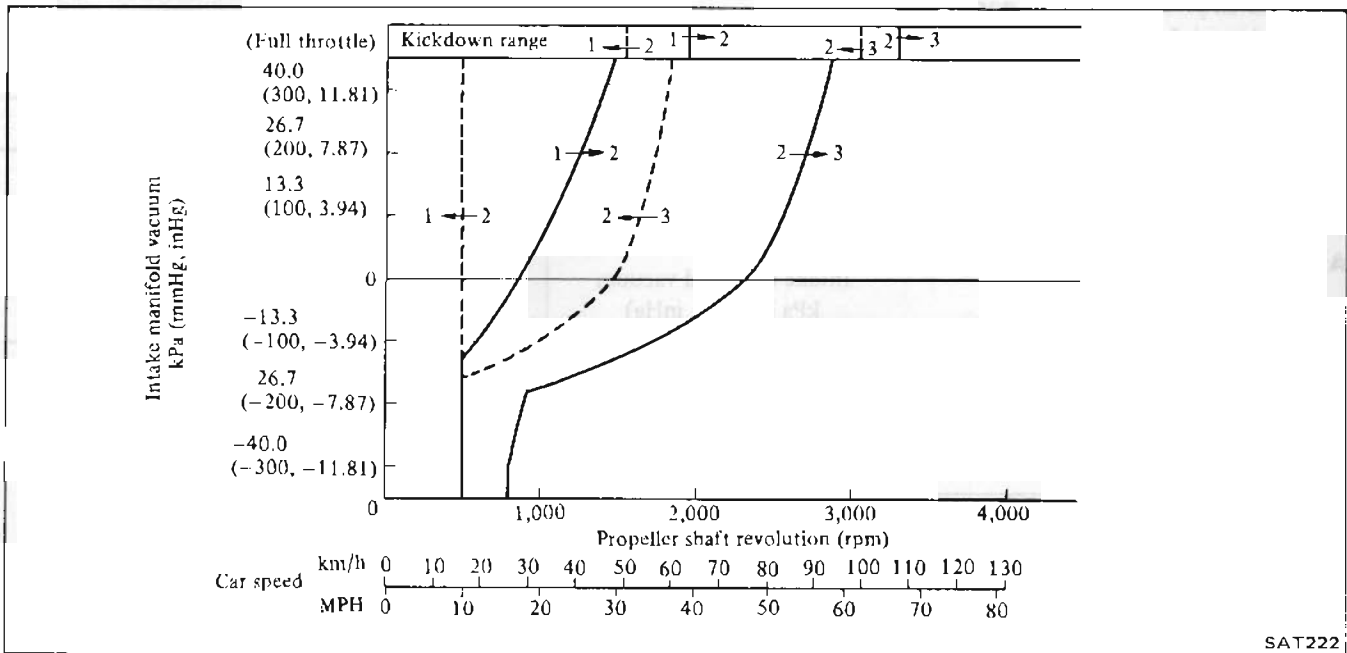

PRESSURE TESTING

The L3N71B transmission is provided with two pressure test ports. Only one is useful for transmission trouble-shooting, Line Pressure.

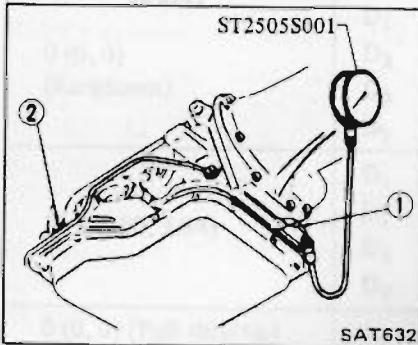

- 1 Line pressure
- 2 Servo release pressure

LINE PRESSURE

1. Install pressure gauge to line pressure port. (When shift lever is in "D", "2" or "1" range, install pressure gauge to port ① and when in "R" range, install pressure gauge to port ③ shown above.) Locate the gauge so it can be seen by driver. Measure line pressure at idling and at stall test.
2. Road test car and note pressure under different throttle conditions.

At stall test

L28E engine model

Range	Line pressure kPa (kg/cm ² , psi)
R	2,089 - 2,393 (21.3 - 24.4, 303 - 347)
D	1,128 - 1,275 (11.5 - 13.0, 164 - 185)
2	1,206 - 1,353 (12.3 - 13.8, 175 - 196)
1	1,128 - 1,275 (11.5 - 13.0, 164 - 185)

L28ET engine model

Range	Line pressure kPa (kg/cm ² , psi)
R	2,158 - 2,452 (22.0 - 25.0, 313 - 356)
D	1,785 - 1,942 (18.2 - 19.8, 259 - 282)
2	1,785 - 1,942 (18.2 - 19.8, 259 - 282)
1	1,785 - 1,942 (18.2 - 19.8, 259 - 282)

Key points of pressure testing are:

- a) Pressure at idle: Look for a steady rise in pressure as car speed increases under light load.
- b) Pressure drop between shift points should not exceed 98 kPa (1.0 kg/cm², 14 psi). Excessive pressure drop may indicate an internal leak at a servo or clutch seal.

Cut-down point

The cut-down point indicates a point where line pressure changes from high to low value as output shaft rotation is gradually increased from "stall" point. The car speed and output shaft rotation at that cut-down point are as indicated in chart below.

L28E engine model

Intake manifold vacuum -kPa (-mmHg, -inHg)	Car speed km/h (MPH)	Propeller shaft revolutions rpm
0 (0, 0)	34 - 42 (21 - 26)	1,040 - 1,290
13.3 (100, 3.94)	19 - 28 (12 - 17)	600 - 850

L28ET engine model

Intake manifold vacuum kPa (mmHg, inHg)	Car speed km/h (MPH)	Propeller shaft revolutions rpm
46.7 (350, 13.78)	43 - 53 (27 - 33)	1,320 - 1,620
-26.7 (-200, -7.87)	13 - 20 (8 - 12)	400 - 600

☐ : means negative pressure.

At idling

L28E engine model

Range	Line pressure kPa (kg/cm ² , psi)
R	510 - 696 (5.2 - 7.1, 74 - 101)
D	314 - 373 (3.2 - 3.8 - 46 - 54)
2	775 - 1,353 (7.9 - 13.8, 112 - 196)
1	314 - 373 (3.2 - 3.8, 46 - 54)

L28ET engine model

Range	Line pressure kPa (kg/cm ² , psi)
R	392 - 490 (4.0 - 5.0, 57 - 71)
D	294 - 392 (3.0 - 4.0, 43 - 57)
2	588 - 1,177 (6.0 - 12.0, 85 - 171)
1	294 - 392 (3.0 - 4.0, 43 - 57)

STALL TESTING

The stall test is an effective method of testing clutch and band holding ability, torque converter one-way clutch operation, and engine performance. A stall test should only be performed as a last resort because of the high fluid temperature it generates and the excessive load it places on the engine and transmission.

CAUTION:

- a. Transmission and engine fluid levels should always be checked and fluid added as needed.
- b. Run engine at 1,200 rpm to attain proper warm-up.
- c. During test, never hold throttle wide-open for more than 5 seconds.
- d. Do Not test more than two gear ranges without driving car to cool off engine and transmission.

STALL TEST PROCEDURE

1. Install a tachometer where it can be seen by driver during test.
2. Set hand brake and block wheels.
3. Start engine and place shift lever in "D" range.
4. Apply foot brake and accelerate to wide-open throttle. Do **not** hold throttle open longer than five seconds.
5. Quickly note the engine stall speed and immediately release throttle.

Stall revolution:

- L28E engine
2,000 - 2,300 rpm
- L28ET engine
2,400 - 2,700 rpm

6. Place shift lever in "R" range and repeat above test (same as in "D" range).

If stall test indicates proper stall revolution in "D" range, no further testing is necessary.

STALL TEST ANALYSIS

1. Satisfactory results in "D" range indicates forward clutch (Rear), one-way clutch of transmission, and sprag clutch of torque converter, are functioning properly.
2. Stall revolution in "D" range, 1st gear, is above specified revolution:
The forward clutch (Rear) is faulty.

3. Stall revolution in "R" range is above specified revolution (for "D" range);

Low and Reverse Brakes are faulty.

4. Stall revolution in "D" range, 1st gear is below specified revolution:

Converter sprag clutch is faulty (slipping), or engine is not performing properly.

If converter sprag clutch is frozen, car will have poor high speed performance. If converter sprag clutch is slipping, car will be sluggish up to 50 or 60 km/h (30 or 40 MPH).

TROUBLE-SHOOTING AND DIAGNOSES

TROUBLE-SHOOTING CHART

Numbers are arranged in order of probability. Perform inspections starting with number one and working up. Circled numbers indicate that the transmission must be removed from the car.

	ON CAR										OFF CAR										
	Oil level	Range select linkage	Inhibitor switch and wiring	Vacuum diaphragm and piping	Kickdown solenoid, switch and wiring	Engine idling rpm	Line pressure	Manual valve Governor	Band servo	Transmission air check	Oil quality	Ignition switch and starter motor	Engine adjustment, brake inspection	Forward clutch (Rear)	High-reverse clutch (Front)	Band brake	Low and reverse brake	Oil pump	Oil passage leak	Transmission one-way clutch	High-reverse clutch (Front) check ball
Engine does not start in "N", "P" ranges.	. 2 3	1
Engine starts in range other than "N" and "P".	. 1 2
Transmission noise in "P" and "N" ranges.	1	2	③
Car moves when changing into "P" range or parking gear does not disengage when shifted out of "P" range	. 1 ②
Car runs in "N" range.	. 1	3	2	④
Car will not run in "R" range (but runs in "D", "2" and "1" ranges.) Clutch slips. Very poor acceleration.	1 2	3	5	6 4	⑨ ⑧	⑦	⑩	⑪
Car braked when shifting into "R" range.	3 2 1	④	⑤ ⑥
Sharp shock in shifting from "N" to "D" range.	2	1 3	4	⑤
Car will not run in "D" range (but runs in "2", "1" and "R" ranges).	. 1	2	3 ④
Car will not run in "D", "1", "2" ranges (but runs in "R" range). Clutch slips. Very poor acceleration.	1 2	4	5	6 3	7	⑧ ⑩	⑨
Clutches or brakes slip somewhat in starting.	1 2	6	3	5	7 4	⑧ ⑨
Excessive creep.	1
No creep at all.	1 2	3	5	4	⑧ ⑨	⑥ ⑦
Failure to change gear from "1st" to "2nd".	. 1	2 3	5 6	8 7 4	⑨	⑩
Failure to change gear from "2nd" to "3rd".	. 1	2 3	5 6	8 7 4	⑨	⑩ ⑪
Too high a gear change point from "1st" to "2nd", from "2nd" to "3rd".	1 2	3	5 6	4	⑦
Gear change directly from "1st" to "3rd" occurs.	2 4	3 1	⑤	⑥

TROUBLE-SHOOTING AND DIAGNOSES

Numbers are arranged in order of probability. Perform inspections starting with number one and working up. Circled numbers indicate that the transmission must be removed from the car.

	ON CAR					OFF CAR		
	Oil level	Range select linkage Vacuum diaphragm and piping	Kickdown solenoid, switch and wiring Line pressure Engine stall rpm	Manual valve Governor Band servo	Transmission air check Oil quality Engine adjustment, brake inspection	Forward clutch (Rear) High-reverse clutch (Front) Band brake	Low and reverse brake Oil pump Oil passage leak	Transmission one-way clutch High-reverse clutch (Front) check ball
Too sharp a shock in change from "1st" to "2nd".	. . 1	. . 2	4 . 5	. 3 .	. . ⑥	
Too sharp a shock in change from "2nd" to "3rd".	. . 1	. 2 .	3 . 5	4 . .	. ⑥	
Almost no shock or clutches slipping in change from "1st" to "2nd".	1 2 3	. 4 .	6 . 8	7 5 .	. . ⑨	. . ⑩	. .	
Almost no shock or slipping in change from "2nd" to "3rd". Engine races extremely fast.	1 2 3	. 4 .	6 . 8	7 5 .	. ⑨ .	. . ⑩	. ⑪	
Car braked by gear change from "1st" to "2nd".	2 . .	. 1 .	. ④ .	③ . .	⑤ .	
Car braked by gear change from "2nd" to "3rd".	3 . 2	. 1 .	. . ④	
Maximum speed not attained. Acceleration poor.	1 2 .	. 4 5	7 . 6	. 3 8	⑪ ⑫ ⑨	⑩ ⑬ .	. .	
Failure to change gear from "3rd" to "2nd".	. . 1	. . .	3 4 6	5 2 .	. ⑦ ⑧	. . ⑨	. .	
Failure to change gear from "2nd" to "1st" or from "3rd" to "1st".	. . 1	. . .	3 4 6	5 2 .	. . ⑦	. . .	⑧ .	
Gear change shock felt during deceleration by releasing accelerator pedal.	. 1 2	3 4 .	5 6 ⑦	. .	
Too high a change point from "3rd" to "2nd", from "2nd" to "1st".	. 1 2	3 4 .	5 6 ⑦	. .	
Kickdown does not operate when depressing pedal in "3rd" within kickdown car speed.	. . 2	1 . .	4 5 .	. 3 .	. . ⑥	. . ⑦	. .	
Kickdown operates or engine over-runs when depressing pedal in "3rd" beyond kickdown car speed limit.	. 1 2	. 3 .	5 6 .	7 4 .	. ⑧ .	. . ⑨	. .	
Races extremely fast or slips in changing from "3rd" to "2nd" when depressing pedal.	. . 1	. 2 .	4 . 6	5 3 .	. ⑦ ⑧	. . ⑨	. ⑩	

TROUBLE-SHOOTING AND DIAGNOSES

Numbers are arranged in order of probability. Perform inspections starting with number one and working up. Circled numbers indicate that the transmission must be removed from the car.

	ON CAR										OFF CAR											
	Oil level	Range select linkage	Vacuum diaphragm and piping	Engine idling rpm	Line pressure	Engine stall rpm	Rear lubrication	Manual valve	Governor	Band servo	Transmission air check	Oil quality	Forward clutch (Rear)	High-reverse clutch (Front)	Band brake	Low and reverse brake	Oil pump	Oil passage leak	Torque converter, one-way clutch	Transmission one-way clutch	Park linkage	Planetary gear
Car will not run in any range.	1 2 .	. 3 .	. 5 .	. 6 4
Transmission noise in "D", "2", "1" and "R" ranges.	1 . .	. 2	③
Failure to change from "3rd" to "2nd" when changing lever into "2" range.	. 1 .	. 2 .	. 4 .	5 . 3
Gear change from "2nd" to "1st" or from "2nd" to "3rd" in "2" range.	. 1 .	. 2 .	. 3
No shock at change from "1" to "2" range or engine races extremely fast.	1 2 3	4 . 5	. 7 .	. 8 6
Failure to change from "3rd" to "2nd" when shifting lever into "1" range.	. 1 .	. 2 .	. 4 5	7 6 3
Engine brake does not operate in "1" range.	. 1 .	. 2 .	. 4 .	. 5 3
Gear change from "1st" to "2nd" or from "2nd" to "3rd" in "1" range.	. 1 2
Does not change from "2nd" to "1st" in "1" range.	1 2 4 5	6 7 3
Large shock changing from "2nd" to "1st" in "1" range.	. . 1	. . 2	. 4 .	. . 3
Transmission overheats.*	1 . .	. 3 4	2 6 .	8 7 5	. 9 10	11 12 13	14 . .	15
Oil shoots out during operation. White smoke emitted from exhaust pipe during operation.	1 . 3	. 5 6	2 7 .	. 8 4	. 9 10	11 12 13	14 . .	15
Offensive smell at oil charging pipe.	1 2	③ ④ ⑤	⑥ ⑦ ⑧	⑨ . .	⑩

*: Refer to page AT-43.

TROUBLE-SHOOTING AND DIAGNOSES

Exclusively for L3N71B

Numbers are arranged in order of probability. Perform inspections starting with number one and working up. Circled numbers indicate that the transmission must be removed from the car.

	ON CAR				OFF CAR				
	Governor tube	Governor	Line pressure	O-ring in input shaft	Torque converter	Speed cut valve	Lock-up control valve	Lock-up orifice in oil pump cover	Oil pump
Torque converter is not locked up	1	2	3	④	⑨	⑥	⑦	⑧	⑤
Lock-up piston slip			1	②	⑤			③	④
Lock-up point is extremely high or low	1	2				③	④		
Engine is stopped at R.D.2 and 1 ranges					②		①		
Transmission overheats			1	②	⑤			③	④

ROAD TEST SYMPTOM CHART

		SHIFT QUALITY				CAR WON'T MOVE	CRUISE SLIPPAGE	POOR POWER/ACCELERATION	NOISY	OK	COMMENTS
		ROUGH	SHIFT TIMING [Mark km/h (MPH)]	NO SHIFT	SHIFT SLIPPAGE						
PARK RANGE	ENG. START										
	HOLDING										
"R" RANGE	Man. shift P-R										
	REVERSE										
"N" RANGE	Man. shift R-N										
	ENG. START										
	N										
"D" RANGE	Man. shift N-D										
	1st										
	Auto shift 1-2										
	2nd										
	Auto shift 2-3										
	3rd										
	Decel. 3-2										
	Kickdown 3-2										
	Decel. 2-1										
	Kickdown 2-1										
"2" RANGE	Man. shift D-2										
	2nd										
"1" RANGE	Man. shift 2-1										
	Man. shift D-1										
	Acceleration										
	"1" Engine Braking										

TROUBLE-SHOOTING GUIDE FOR L3N71B AUTOMATIC TRANSMISSION

Order	Test item	Procedure
Checking	<ol style="list-style-type: none"> 1. Oil level gauge 2. Downshift solenoid 3. Manual linkage 4. Inhibitor switch 5. Engine idling rpm. 6. Vacuum pressure of vacuum pipe. 7. Operation in each range. 8. Creep of car. 	<p>Check gauge for oil level and leakage before and after each test.</p> <p>Check for sound of operating solenoid when depressing accelerator pedal fully with ignition key "ON".</p> <p>Check by shifting into "P", "R", "N", "D", "2" and "1" ranges with selector lever.</p> <p>Check whether starter operates in "N" and "P" ranges only and whether reverse lamp operates in "R" range only.</p> <p>Check whether idling rpm meet standard.</p> <p>Check whether vacuum pressure is more than 60.0 kPa (450 mmHg, 17.72 inHg) in idling and whether it decreases with increasing rpm.</p> <p>Check whether transmission engages positively by shifting "N" → "D", "N" → "2", "N" → "1" and "N" → "R" range while idling with brake applied.</p> <p>Check whether there is any creep in "D", "2", "1" and "R" ranges.</p>
Stall test	<ol style="list-style-type: none"> 1. Oil pressure before testing. 2. Stall test. 3. Oil pressure after testing 	<p>Measure line pressures in "D", "2", "1" and "R" range while idling.</p> <p>Measure engine rpm and line pressure in "D", "2", "1" and "R" ranges during full throttle operation.</p> <p>Temperature of torque converter oil used in test should be from 60 to 100°C (140 to 212°F) i.e., sufficiently warmed up but not overheated.</p> <hr/> <p>CAUTION: To cool oil between each stall test for "D", "2", "1" and "R" ranges, idle engine, i.e., rpm at about 1,200 rpm for more than 1 minute in "P" range. Measurement time must not be more than 5 seconds.</p> <hr/> <p>Same as item 1.</p>
Road test	<ol style="list-style-type: none"> 1. Slow acceleration, 1st → 2nd 2nd → 3rd 2. Quick acceleration, 1st → 2nd 2nd → 3rd 3. Kick-down operation, 3rd → 2nd or 2nd → 1st 	<p>Check car speeds and engine rpm in shifting up 1st → 2nd range and 2nd → 3rd range and when torque converter is locked up while running with lever in "D" range and engine vacuum pressure of about 13.3 kPa (100 mmHg, 3.94 inHg).</p> <p>Same as item 1 above except with engine vacuum pressure of 0 kPa (0 mmHg, 0 inHg) (i.e., in position just before kickdown).</p> <p>Check whether the kickdown operates and measure the time delays while running at 30, 40, 50, 60, 70 km/h (19, 25, 31, 37, 43 MPH) in "D₃" range.</p>

TROUBLE-SHOOTING AND DIAGNOSES

Order	Test item	Procedure
	<p>4. Shift down, D₃ → D₂ → D₁</p> <p>5. Shift down, D₃ → I₂ → I₁</p> <p>6. Shift down, D₃ → 2</p> <p>7. Shift up, I₁ → I₂</p> <p>8. Shift up or down when starting in "2" range.</p> <p>9. Parking.</p>	<p>Check car speeds and engine rpm in shifting down from 3rd → 2nd → 1st (sequentially) while coasting with accelerator pedal released in "D₃" range and engine vacuum pressure of about 60.0 kPa (450 mmHg, 17.72 inHg).</p> <p>Check for shifting down D₃ → I₂ and engine braking, and further for shifting down I₂ → I₁ and engine braking after shifting the lever into "I" range with the accelerator pedal released and the engine vacuum pressure of 0 kPa (0 mmHg, 0 inHg) while driving at about 50 km/h (30 MPH) in "D₃" range.</p> <p>Check for quick shifting down D₃ → 2 and engine braking, after shifting the lever into "2" range while driving at about 50 km/h (30 MPH) in "D₃" range.</p> <p>Also, check for locking of the transmission in 2nd gear ratio regardless of car speed.</p> <p>Check for failure of the transmission to shift up during acceleration, when starting in "I" range.</p> <p>Check the transmission for not shifting up or down during acceleration or deceleration, when starting in "2" range.</p> <p>Confirm that car will not move on grade when shifting to "P" range.</p>
Others	Abnormal shock, oil leakage.	Enter into record conditions observed during these tests such as gear noise, abnormal clutch noise and acceleration performance.

SERVICE DATA AND SPECIFICATIONS (S.D.S.)

General specifications

Engine model	L28E	L28ET
Automatic transmission model	L3N71B	3N71B
Stall torque ratio	2.0 : 1	2.0 : 1
Transmission gear ratio		
1st	2.458	2.458
2nd	1.458	1.458
Top	1.000	1.000
Reverse	2.182	2.182
Oil	Automatic transmission fluid "Dexron" type	
Oil capacity	6.1 liters (6-1/2 US qt, 5-3/8 Imp qt)	5.5 liters (5-7/8 US qt, 4-7/8 Imp qt)

Specifications and adjustment

Engine model	L28E	L28ET
Automatic transmission assembly Model code number	X6703	X2770
Torque converter assembly Stamped mark on the T/C	GH	A
High-reverse clutch (Front)		
Number of drive plates	3	4
Number of driven plates	5	5
Clearance mm (in)	1.6 - 2.0 (0.063 - 0.079)	
Thickness of retaining plate	Thickness mm (in)	Part number
	5.0 (0.197)	31567-X2900
	5.2 (0.205)	31567-X2901
	5.4 (0.213)	31567-X2902
	5.6 (0.220)	31567-X2903
	5.8 (0.228)	31567-X2904
	6.0 (0.236)	31567-X2905
	6.2 (0.244)	31567-X2906

Engine model	L28E	L28ET
Forward clutch (Rear)		
Number of drive plates	6	6
Number of driven plates	6	6
Clearance mm (in)	0.8 - 1.6 (0.031 - 0.063)	
Thickness of retaining plate mm (in)	4.80 (0.1890)	
Low & reverse brake		
Number of drive plates	5	7
Number of driven plates	5	7
Clearance mm (in)	0.80 - 1.25 (0.0315 - 0.0492)	
Thickness of retaining plate	Thickness mm (in)	Part number
	7.8 (0.307)	31667-X0500
	8.0 (0.315)	31667-X0501
	8.2 (0.323)	31667-X0502
	8.4 (0.331)	31667-X0503
	8.6 (0.339)	31667-X0504
	8.8 (0.346)	31667-X0505

Brake band		
Piston size mm (in)		
Big dia.	64 (2.52)	72 (2.83)
Small dia.	40 (1.57)	44 (1.73)
Control valve assembly		
Stamped mark on strainer	MEM	TRBK
Governor assembly		
Stamped mark on governor body	M33	M33

Stall revolution

Engine model	L28E	L28ET
Stall revolution rpm	2,000 - 2,300	2,400 - 2,700

SPECIAL SERVICE TOOLS



Tightening torque

Unit	N·m	kg·m	ft·lb
Drive plate to crankshaft	137 - 157	14.0 - 16.0	101 - 116
Drive plate to torque converter	39 - 49	4.0 - 5.0	29 - 36
Converter housing to engine	39 - 49	4.0 - 5.0	29 - 36
Transmission case to converter housing	44 - 54	4.5 - 5.5	33 - 40
Transmission case to rear extension	20 - 25	2.0 - 2.5	14 - 18
Oil pan to transmission case	4.9 - 6.9	0.5 - 0.7	3.6 - 5.1
Servo piston retainer to transmission case	4.9 - 6.9	0.5 - 0.7	3.6 - 5.1
Piston stem (when adjusting band brake)	*12 - 15	*1.2 - 1.5	*9 - 11
Piston stem lock nut	15 - 39	1.5 - 4.0	11 - 29
One-way clutch inner race to transmission case	13 - 18	1.3 - 1.8	9 - 13
Control valve body to transmission case	5.4 - 7.4	0.55 - 0.75	4.0 - 5.4
Lower valve body to upper valve body	2.5 - 3.4	0.25 - 0.35	1.8 - 2.5





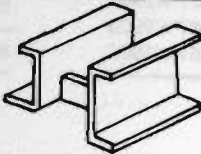
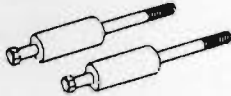

Unit	N·m	kg·m	ft·lb
Side plate to control valve body	2.5 - 3.4	0.25 - 0.35	1.8 - 2.5
Nut for control valve reamer bolt	4.9 - 6.9	0.5 - 0.7	3.6 - 5.1
Oil strainer to lower valve body	2.9 - 3.9	0.3 - 0.4	2.2 - 2.9
Governor valve body to oil distributor	4.9 - 6.9	0.5 - 0.7	3.6 - 5.1
Oil pump housing to oil pump cover	5.9 - 7.8	0.6 - 0.8	4.3 - 5.8
Inhibitor switch to transmission case	4.9 - 6.9	0.5 - 0.7	3.6 - 5.1
Manual shaft lock nut	29 - 39	3.0 - 4.0	22 - 29
Oil cooler pipe to transmission case	29 - 49	3.0 - 5.0	22 - 36
Test plug (oil pressure inspection hole)	14 - 21	1.4 - 2.1	10 - 15
Support actuator (parking rod inserting position) to rear extension	7.8 - 10.8	0.8 - 1.1	5.8 - 8.0

* Turn back two turns after tightening.

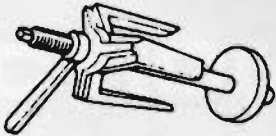
SPECIAL SERVICE TOOLS

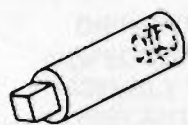
Tool number (Kent-Moore No.)	Tool name
ST07870000 (-) (ST07860000) (J25605)	Transmission case stand 
ST25850000 (J25721)	Sliding hammer 
GG91060000 (-) (GG93010000) (J25703)	Torque wrench 

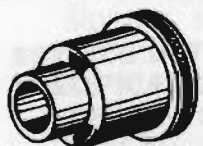
SPECIAL SERVICE TOOLS

Tool number (Kent-Moore No.)	Tool name
ST25420001 (J26063) (ST25420000) (J26063)	Clutch spring compressor 
ST25570001 (J23659) (ST25570000) (J23659)	Hex-head extension 
ST25490000 (-) (ST25512001) (J25713)	Socket extension 
HT62350000 (-)	Spinner handle 
ST25160000 (-)	Torque driver 
ST25580001 (J25719)	Oil pump assembling gauge 
HT61000800 (-)	Hexagon wrench 
ST2505S001 (J25695)	Oil pressure gauge set 